

# **Renewable Energy & Hydroelectric Works**

**8th semester, School of Civil Engineering**

**2nd semester, Master's Programme "Water Resources Science & Technology"**

## **Hydroturbines**

**Andreas Efstratiadis, Georgia-Konstantina Sakki & Athanasios Zisos**

**Department of Water Resources & Environmental Engineering, NTUA**

**Academic year 2023-24**

# Key concepts & classification

- A hydraulic turbine or hydroturbine (from the Latin *turba*, meaning vortex, transliteration of the Greek *τύρβη*, meaning turbulence) is a rotary mechanical structure that converts the available **hydraulic energy** of water (expressed in terms of **net head**) into **mechanical work** (energy of rotating shaft), while the generator attached to the shaft converts mechanical energy into electrical energy.
- Water can be guided to the turbine in two ways, thus also determining how the energy is exchanged between the fluid and the turbine:
  - through **nozzles**, passing through which it hits the buckets of the turbine and rotates the wheel (**action** or **impulse** turbines, using only kinetic energy that strikes the buckets to cause rotation);
  - through **inlet guide vanes** that direct water to the turbine wheel (**reaction turbines**, operating under pressure, since the chamber of the runner is filled by water).
- Hydroturbines are also classified according to the main direction of flow as:
  - **Axial flow**: water flows through the turbine parallel to the axis of rotation;
  - **Radial flow**: water flows through the turbine perpendicular to the axis of rotation;
  - **Mixed flow**: water flows through in a combination of both radial and axial flows.

# Impulse turbines: Overview

- ❑ Widely known as **Pelton wheels**, in honor of the American engineer Lester Allan Pelton, who patented this machine in 1889, by streamlining the traditional windmill technology.
- ❑ A jet of water passing from a **contracting nozzle** (also employing **flow control**) enters the **double buckets** of the turbine wheel, to produce mechanical energy as the runner rotates; after impinging the buckets, the water outflows freely, i.e., under atmospheric pressure.
- ❑ Large turbines may comprise more nozzles, to allow jets impinging at different locations of the wheel.
- ❑ As the load on the turbine changes, the speed of the turbine varies accordingly, which changes the frequency of the electricity. To maintain the frequency and the speed of the turbine, the flow rate through the turbine is controlled by the valve mounted on the jet.
- ❑ Since the jet flow is not axisymmetric, part of the runner is activated (typically two or three out of about 20 buckets), thus also referred to as **partial admission**.

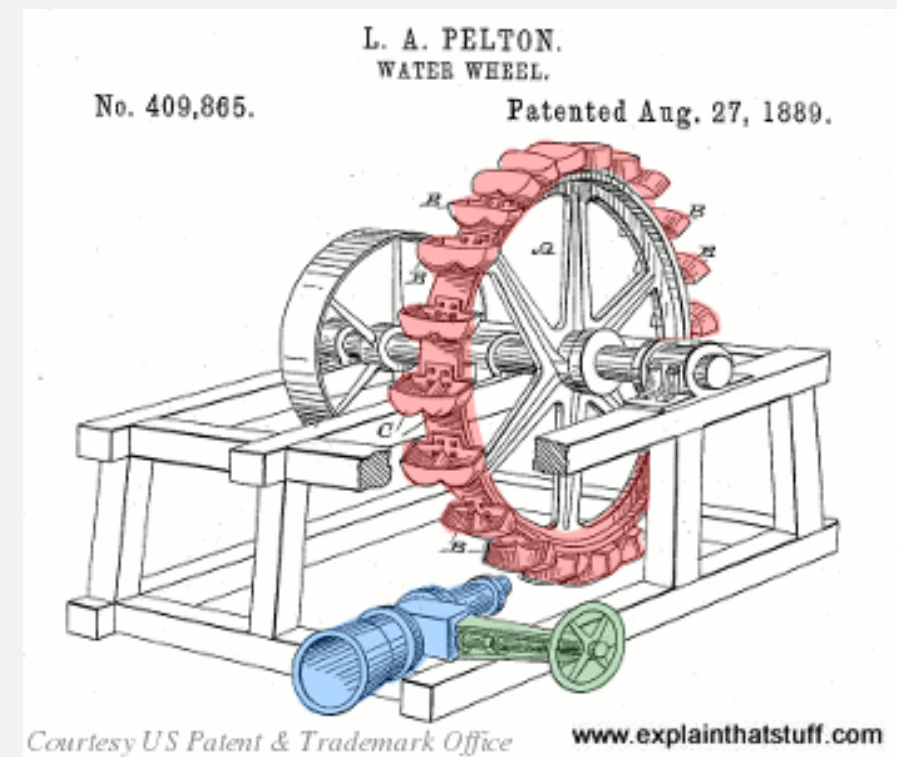

# Impulse turbines: Characteristic sketches

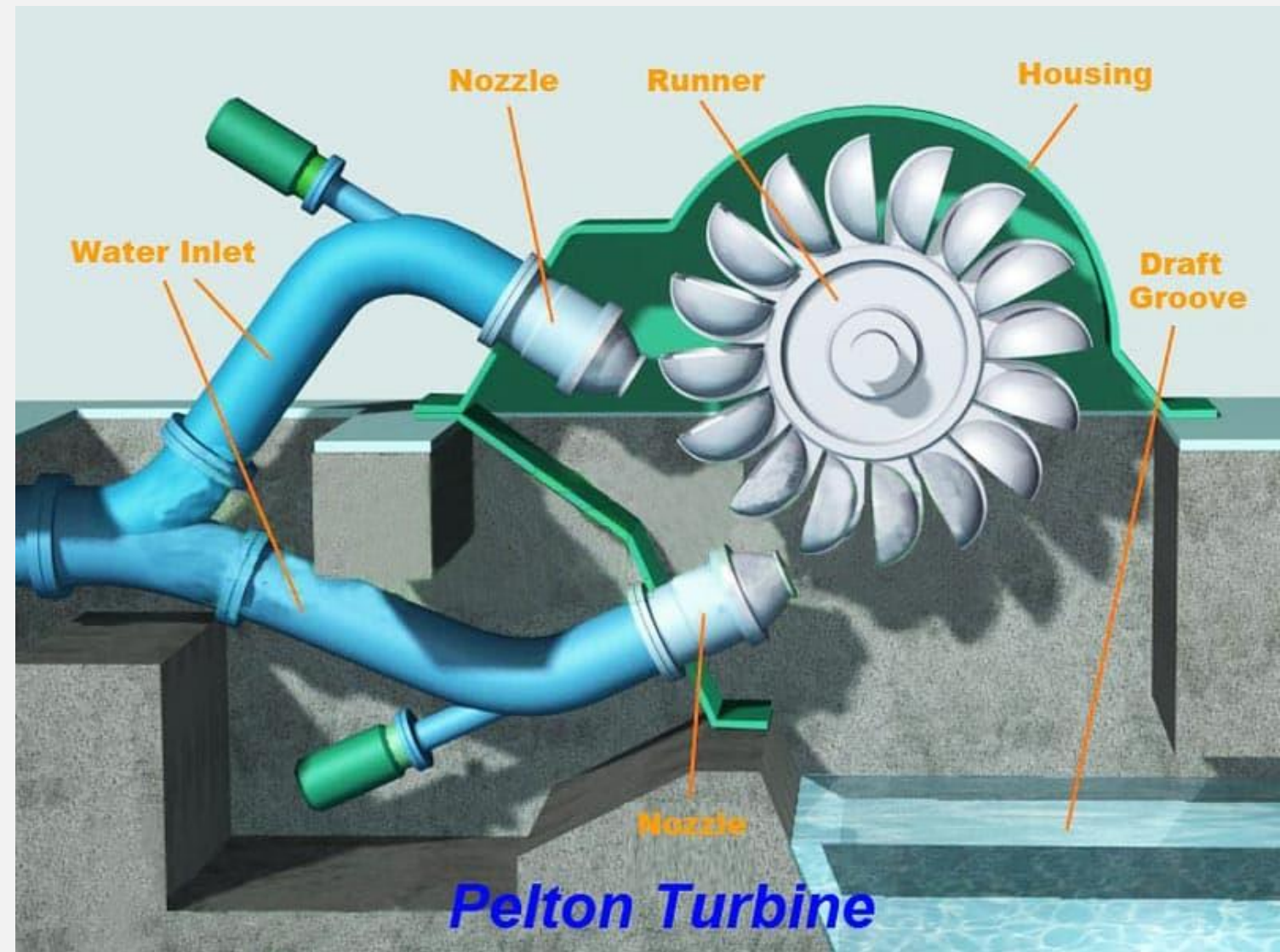
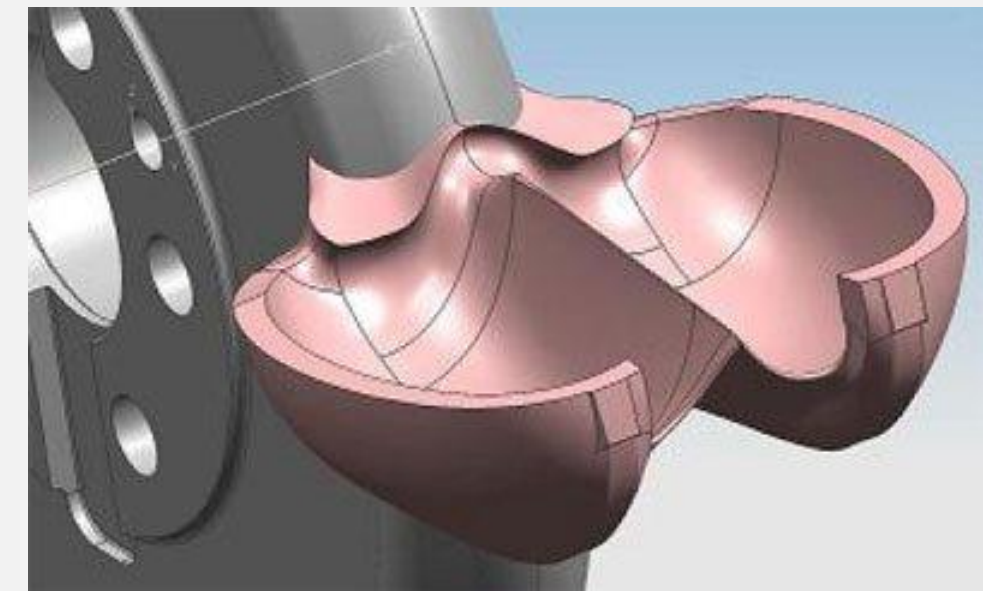
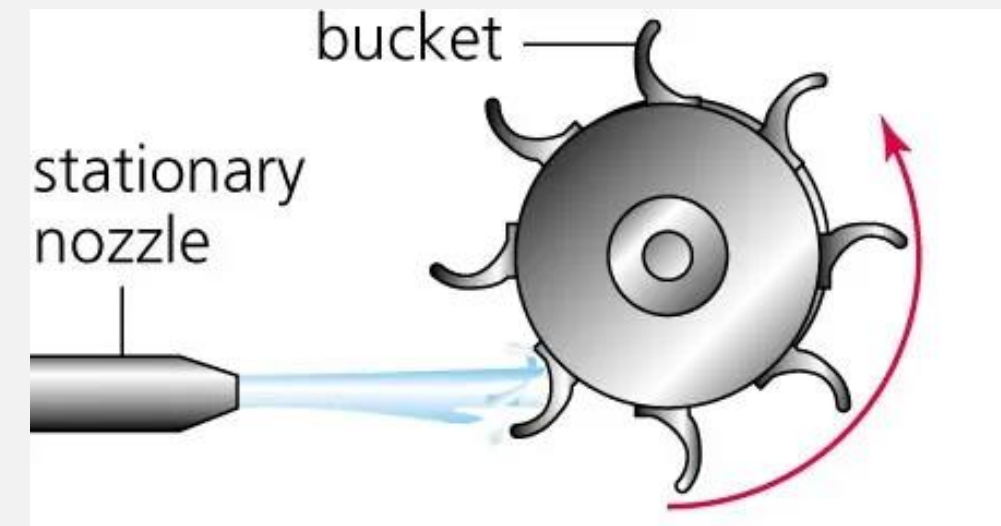

# Impulse turbines: Hydraulic calculations

- Hydraulic losses from section 1 to 3 are:

$$\Delta H = \frac{V^2}{2g} \left[ f \frac{L}{D} + \sum k_i + k_N \left( \frac{D}{D_N} \right)^2 \right]$$

where  $Q$  is the discharge,  $L$  and  $D$  the penstock length and diameter, respectively,  $f$  the friction factor,  $\sum k_i$  the sum of minor energy loss coefficients between sections 1 and 2,  $D_N$  the nozzle diameter, and  $k_N$  the loss coefficient in the transition from the penstock to the nozzle.

- The objective is to substantially increase the flow velocity across the penstock from  $V$  to an output velocity  $V_N$ , thus converting the available hydraulic energy (net head) into kinetic energy; by applying the continuity equation we get:

$$Q = V \frac{\pi D^2}{4} = V_N \frac{\pi D_N^2}{4} \Rightarrow V_N = V \left( \frac{D}{D_N} \right)^2 \Rightarrow H_n = \frac{V_N^2}{2g}$$

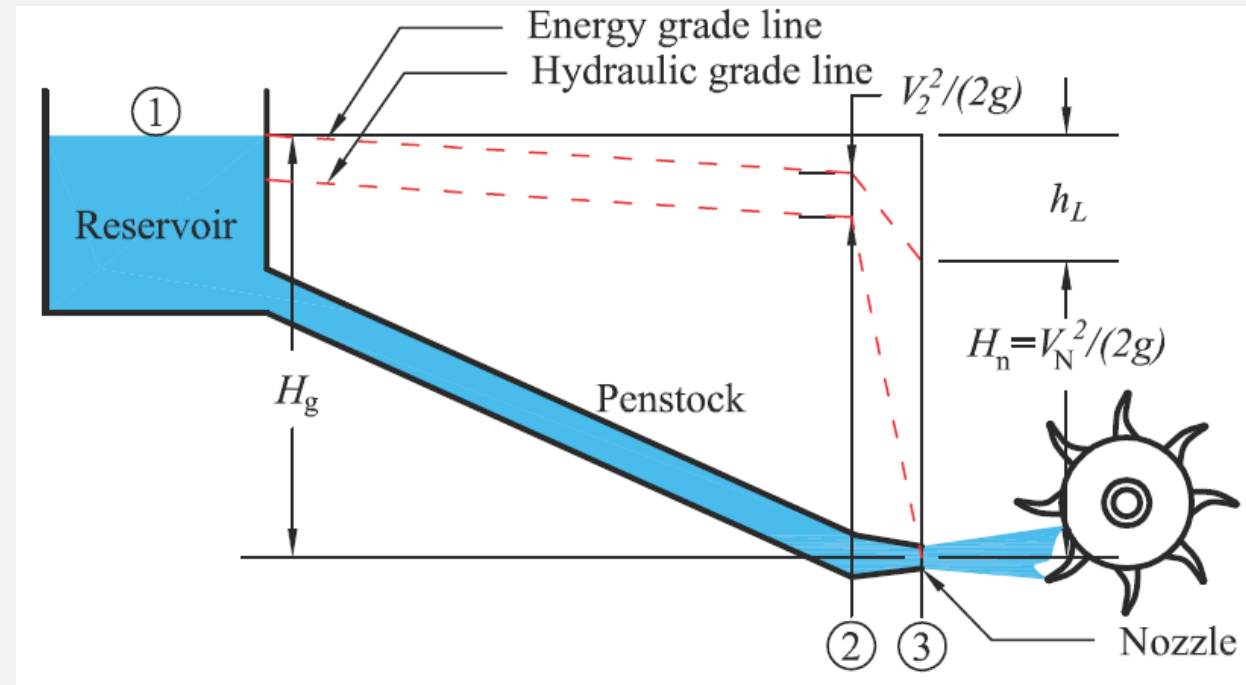

# Impulse turbines: Design issues

- ❑ Pelton-type impulse turbines are applicable for **large heads** and relatively **small flow rates**.
- ❑ The design flow of impulse turbines should be generally low, while the diameter of the penstock should be large enough, to ensure **minimal friction losses** along the pipe.
- ❑ An appropriate design of the nozzle should ensure **minimal local losses due to flow contraction**, thus resulting to small  $k_N$  values; in typical Pelton turbines,  $k_N$  ranges from 0.02 to 0.04.
- ❑ In hydraulic calculations, friction losses across the nozzle are generally omitted, since its length is negligible.

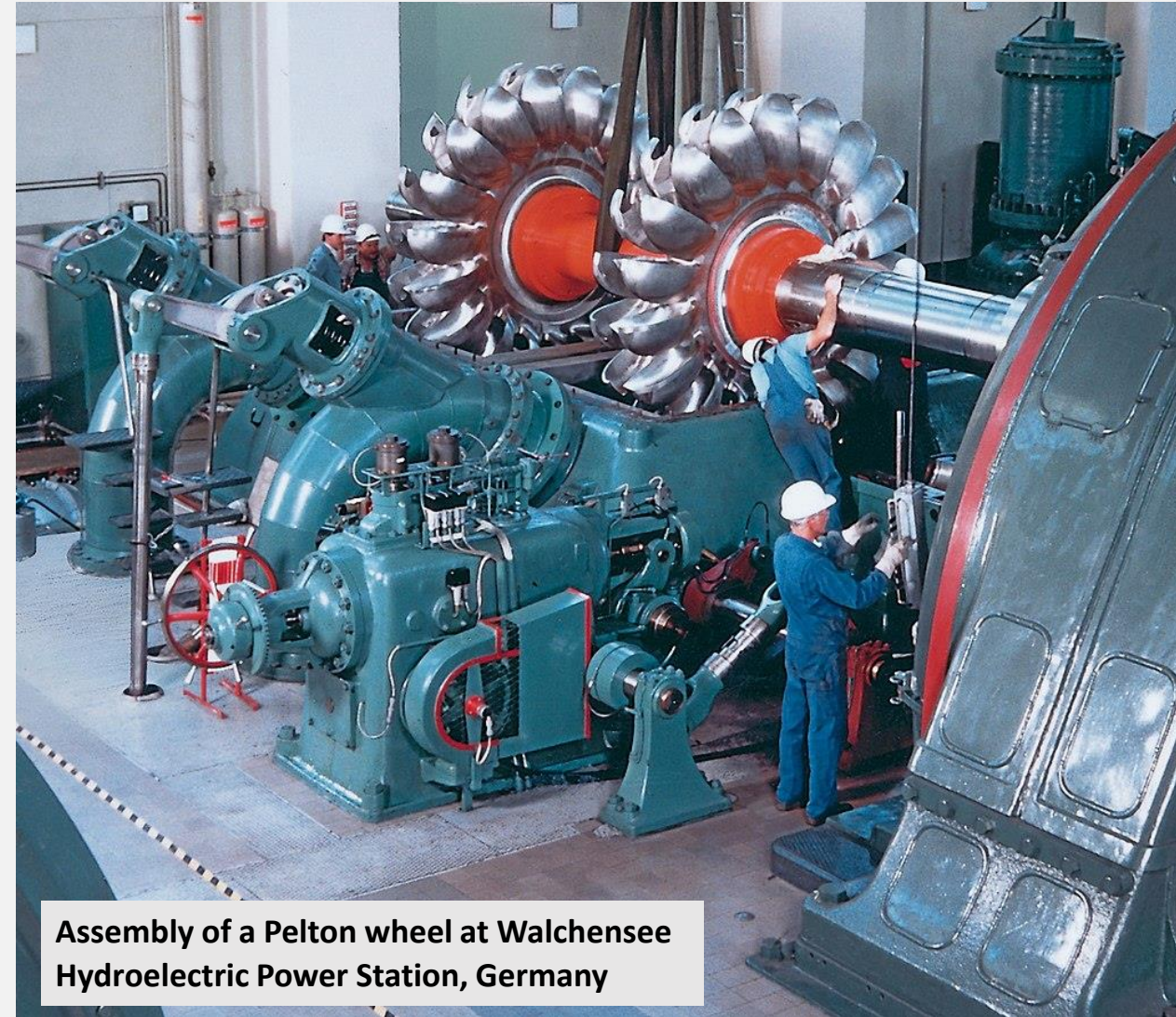

Assembly of a Pelton wheel at Walchensee Hydroelectric Power Station, Germany

# Other types of impulse turbines

- ❑ **Turgo turbines:** They use single instead of double buckets on the wheel that are shallower than the Pelton ones, thus the runner is less expensive. In contrast to Pelton, the jet is horizontal and has higher specific speed, thus it can handle a greater flow than the same diameter of a Pelton wheel, leading to reduced generator and installation cost. They work with net heads between 15 and 300 m, where the Francis and Pelton overlap.
- ❑ **Cross-flow turbines:** The water passes through the turbine transversely or across the turbine blades, and after passing to the inside of the runner, it leaves on the opposite side. Passing through the runner twice provides additional efficiency, also allowing self-cleaning from small debris, leaves etc. Another advantage of cross-flow turbines is the practically flat efficiency curve under varying loads, which makes them ***ideal for run-of-river hydropower plants.***

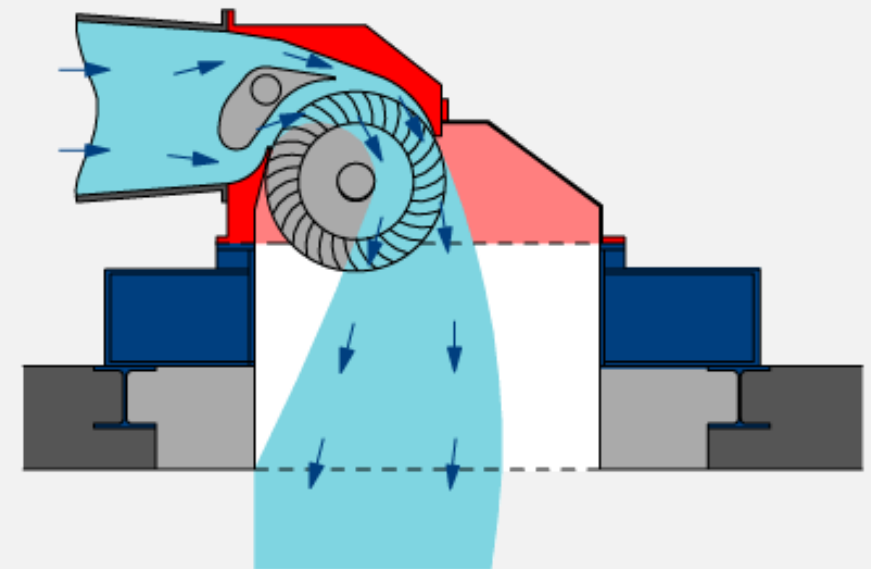
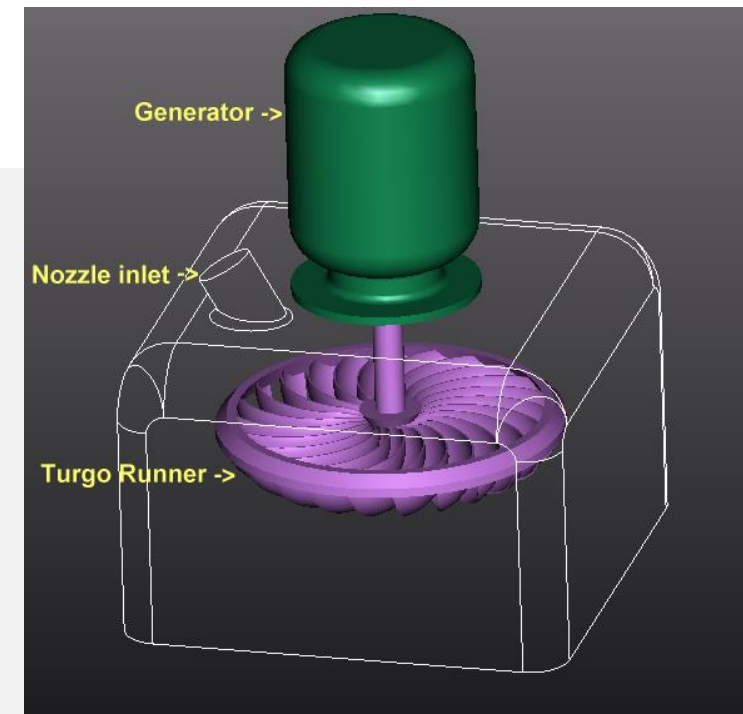

# Reaction turbines: Overview

- ❑ Reaction turbines generate power from the combined forces of **pressure** and **kinetic energy**. A runner is placed directly in the water stream, allowing water to flow over the blades rather than striking each individually. The flow remains pressurized, since the chamber of the runner is filled by water.
- ❑ The runner consists of several **guide vanes** that direct the flow at design angles to the runner blade, thus producing forces due to change of momentum, which in turn make the runner rotating.
- ❑ After leaving the runner, the water enters a **draft tube**, before being extracted to the **tailrace**. The draft tube is shaped for **decelerating the flow** with the minimum possible losses, to regain the kinetic energy of water, coming out of the runner. This permits the turbine to be set above the tailwater, without significant drop of head.
- ❑ Applicable for hydropower systems of **low to medium heads** and **large discharge**.

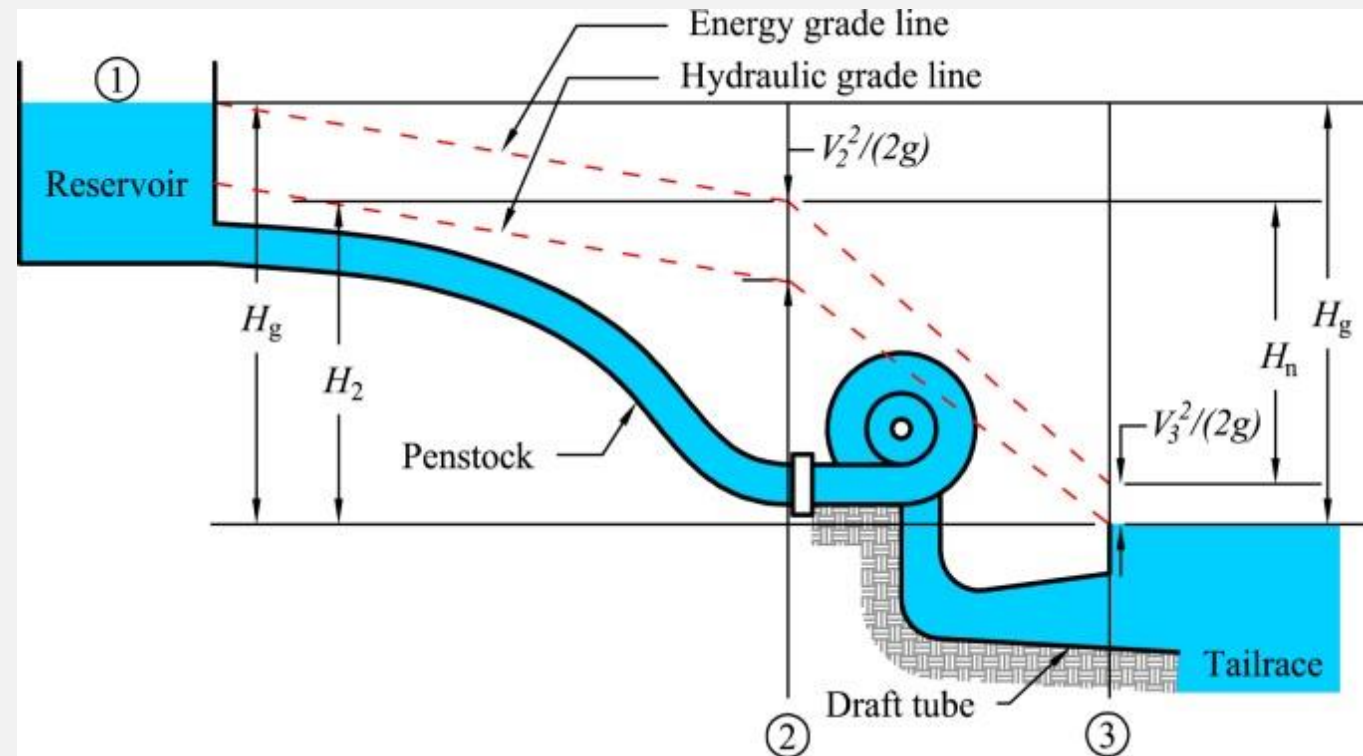



# Reaction turbines: Classification

- Francis turbines, which are suitable for a wide range of flow and head conditions, thus being the most common worldwide (all but two large systems in Greece employ Francis turbines);
- Propeller (also referred to as Kaplan) turbines, employed in cases of high-flow and low-head power production (instream hydropower works at large rivers, tidal stations).

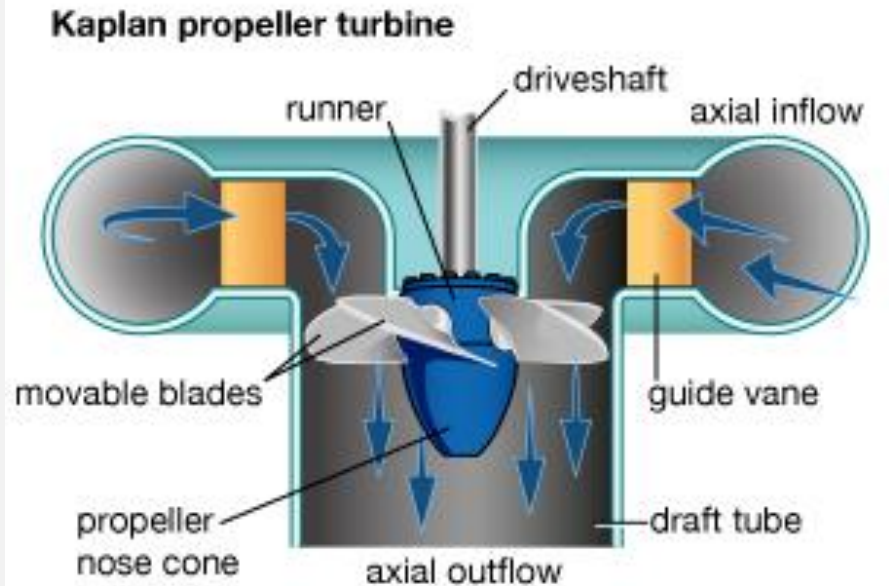
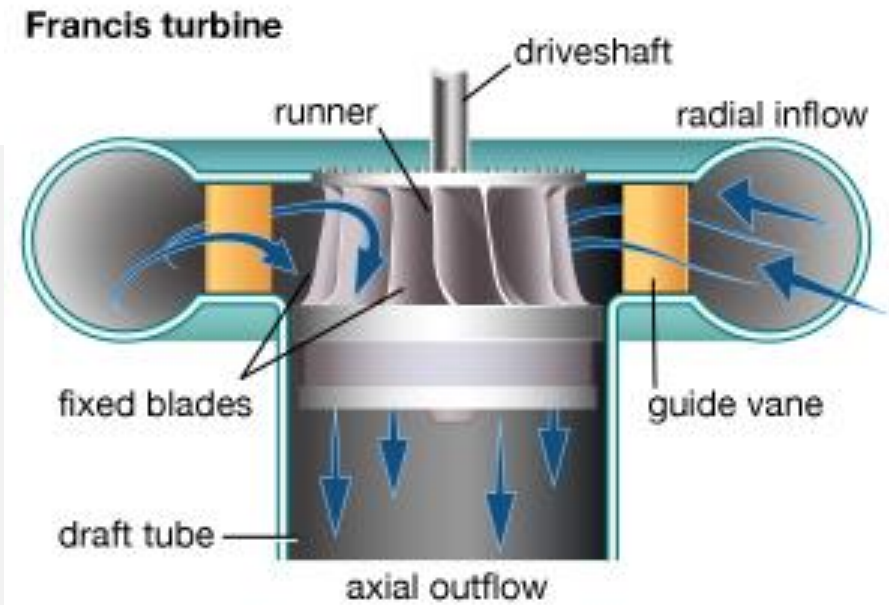

*Francis turbines at Ladonas hydropower station*

# Main components of Francis-type turbines

- ❑ **Spiral (scroll) case:** Inlet medium of water to the turbine. The blades of the turbines are circularly placed, thus the water striking the turbines blades should flow in the circular axis for efficient striking. To maintain the same pressure, the diameter of the casing is gradually reduced.
- ❑ **Stay vanes:** Stationary stay vanes and guide vanes work in tandem to guide the water flow toward the runner blades. Stay vanes prevent radial flow-induced swirling, improving the turbine's efficiency.
- ❑ **Guide vanes:** They control the angle of flow striking the turbine blades, thus optimizing efficiency. They also regulate the flow into the runner blades, allowing the power output to be adjusted on the load.
- ❑ **Runner blades:** In Francis turbines, they are divided into two parts: the lower half is shaped like small buckets, using impulse action for rotation, and the upper part utilizing the reaction force of flow. The combination of these forces facilitates the rotation of the runner.
- ❑ **Draft tube:** Since the exit pressure is generally lower than the atmospheric, the tube is gradually widening and submerging to generate a suction head at the runner exit, which facilitates the smooth transition of flow to the tailrace.

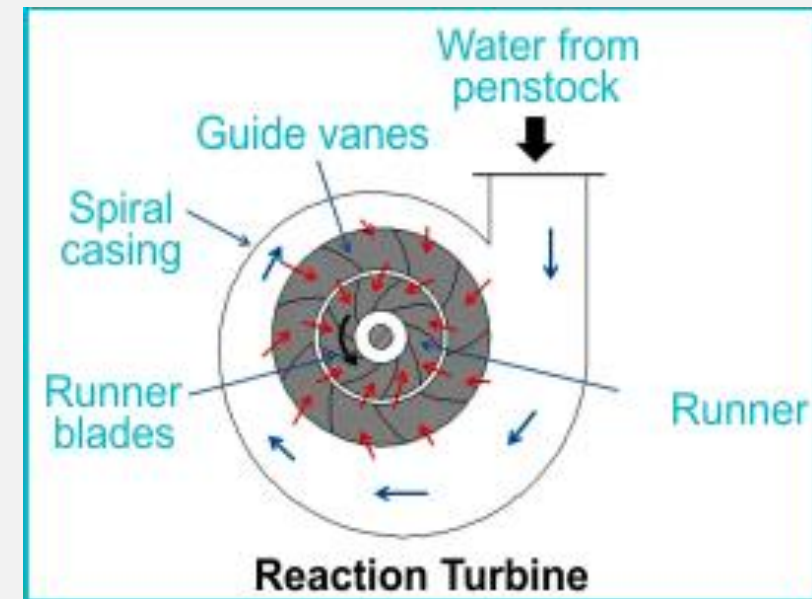

# Francis turbines: Characteristic sketches

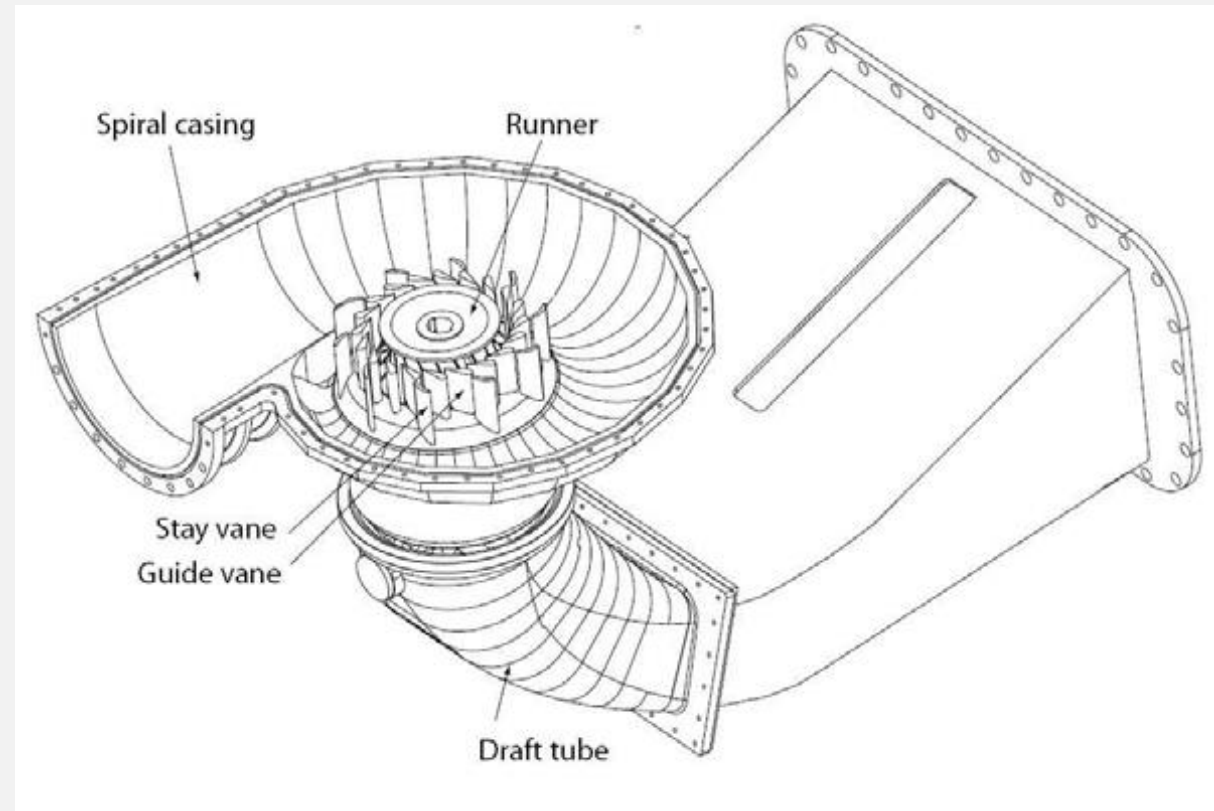
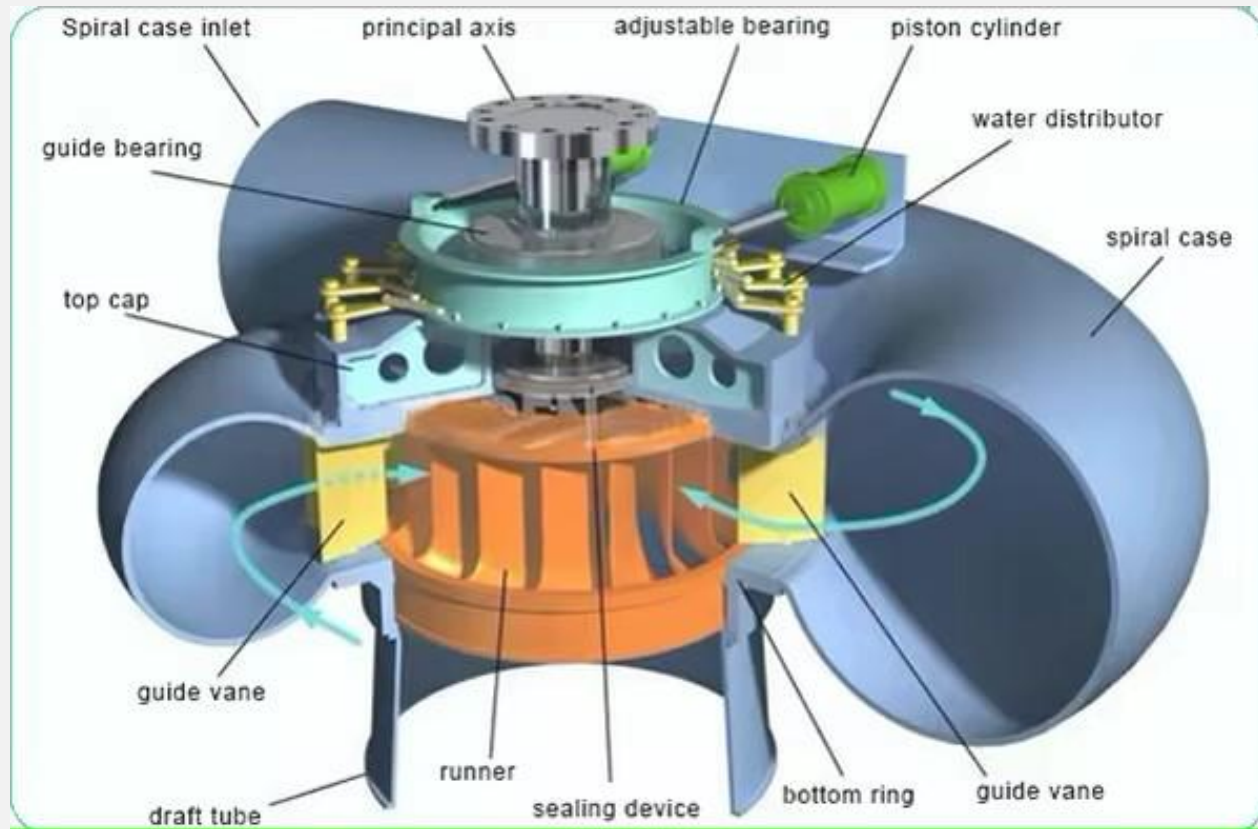

**Advantages:** Applicable for wide range of head and flow; large efficiency; easy control on changing head; small size of runner and generator; small drop in efficiency over time; operating head can be utilized even when the tailwater level is varying; may also be used as reversible turbines in pumped-storage systems.

**Disadvantages:** Cavitation, drop of efficiency and even more prone to cavitation under low head

# Francis turbines: Scroll case and runner

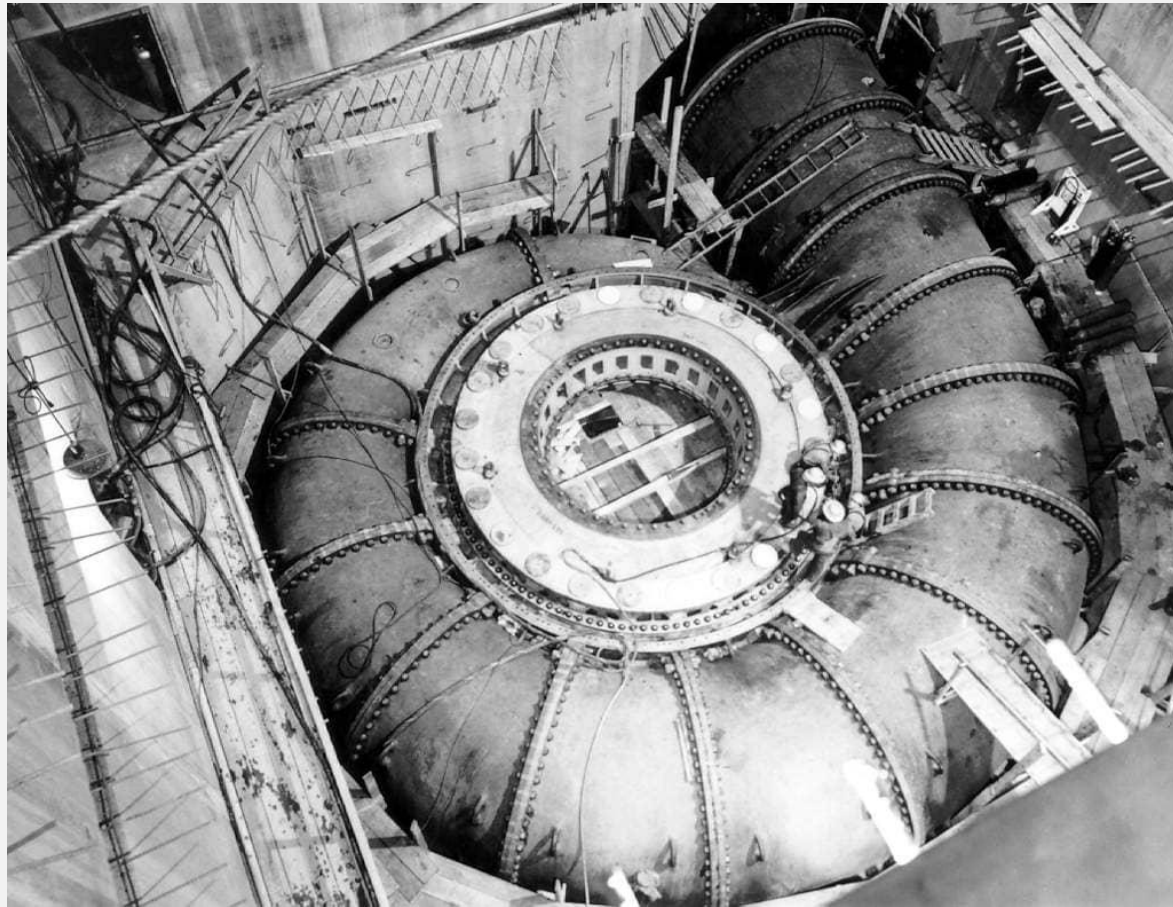

*Francis turbine scroll case*



*Francis turbine runner*

# Francis turbines: Stay and guide vanes

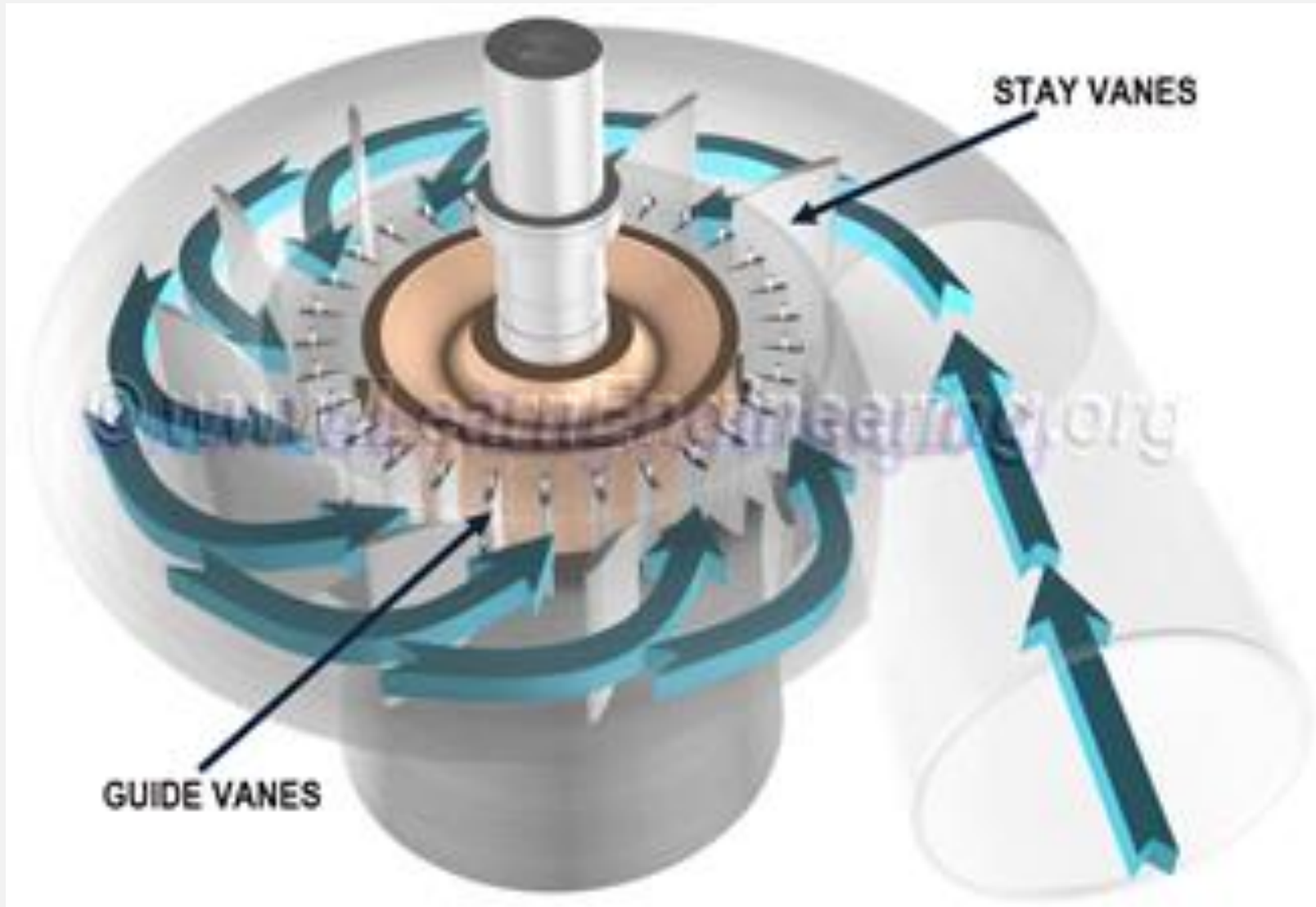

*Wicket gates (yellow) at minimum (upper) and full (lower) flow settings*

# Range of application of different turbine types

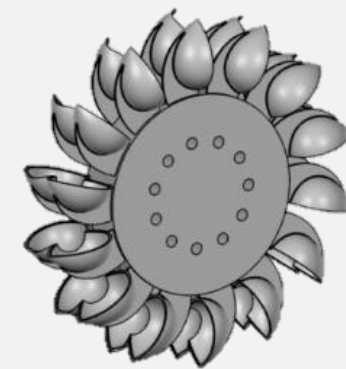
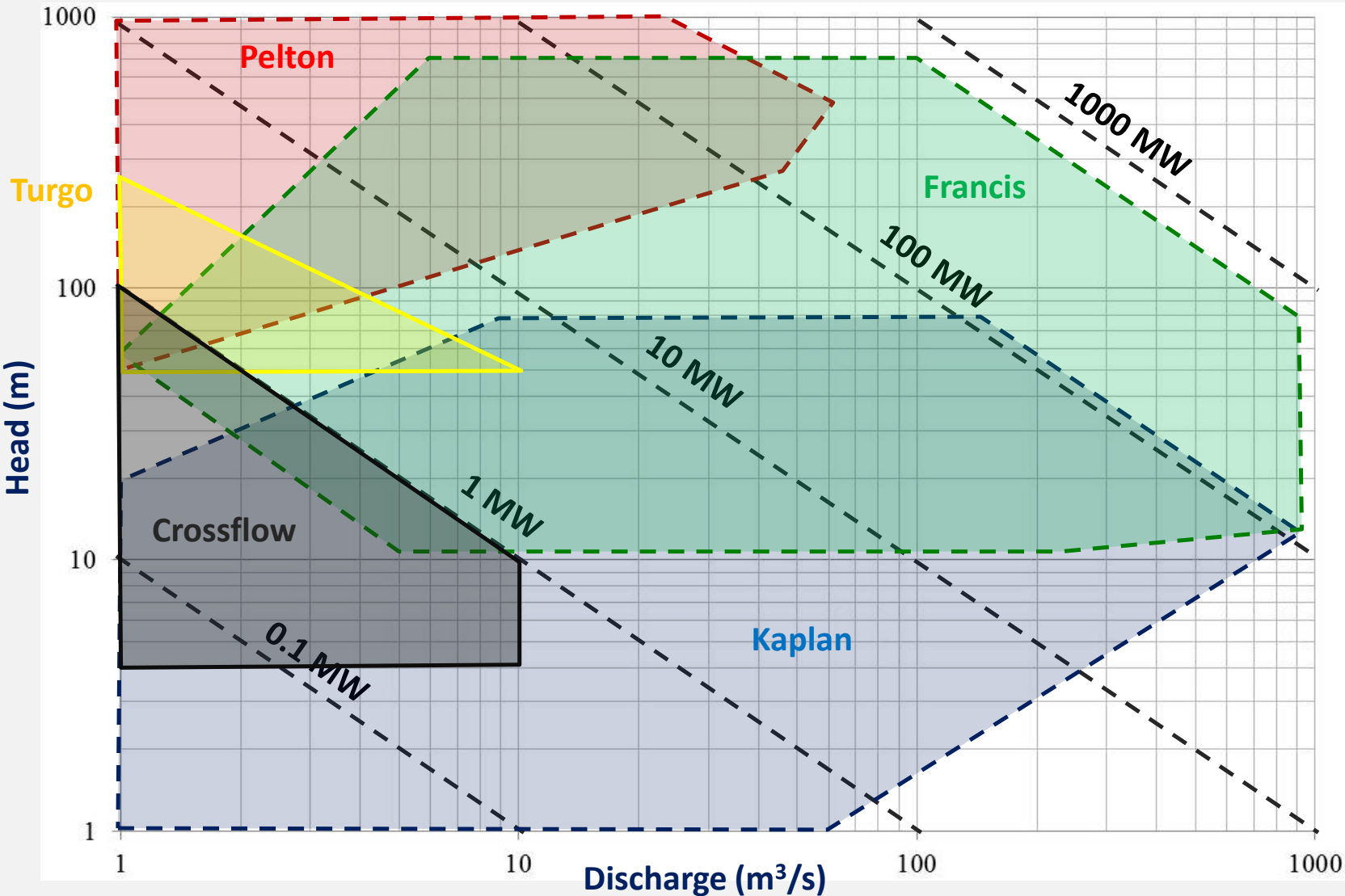

Pelton

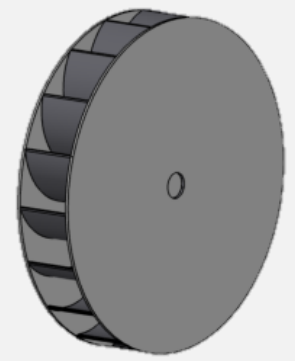

crossflow

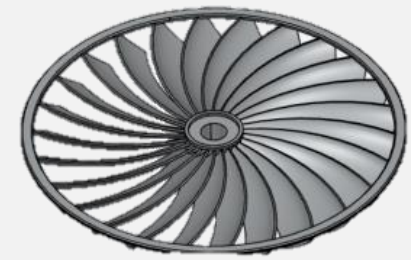

turgo

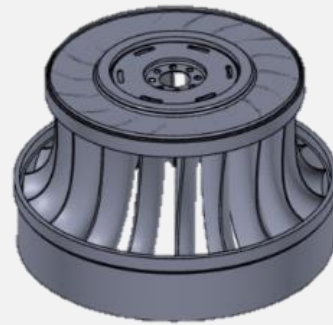

Francis

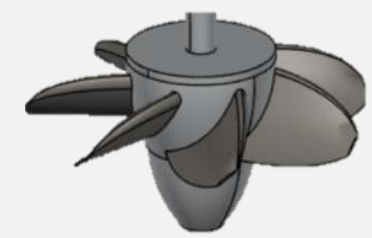

Kaplan

# Total efficiency and its components

- The total efficiency (or simply efficiency,  $\eta$ ) is the ratio of the electric energy provided to the electricity grid to the hydraulic energy provided to the turbine (net head). Its value is subject of **scale** and **turbine type**. For large systems, its maximum value may reach 95% (for Francis turbines), while in small plants, with output power less than 5 MW, the maximum total efficiency may range from 80 to 85%.

- The total efficiency is the **product of four individual components**, i.e.:

$$\eta = \eta_T \eta_G \eta_{TR} \eta_E$$

where  $\eta_T$  refers to the turbines,  $\eta_G$  to the generator,  $\eta_{TR}$  to the transformer, and  $\eta_E$  to transmission lines. Typical values for the three latter are 96%, 98% and 0.98%, respectively (total product  $\sim 95\%$ ).

- The **turbine efficiency** is defined as the ratio of the mechanical energy provided by the turbine to the net head. The difference between the two energy quantities is due to:
  - **Hydraulic losses**, due to friction losses of the fluid layers in motion, friction losses due to water crash on blades, local losses due to changes of tube section, etc. (6-10%);
  - **Volumetric losses** (only for impulse turbines), due to small amounts of water that are extracted to the atmosphere, without crashing on the blades (2-3%);
  - **Mechanical losses** that are developed in the rotating parts of the turbine (1-2%).

# Turbine efficiency

- Turbines are designed for a specific **range of head and flow**, while their efficiency over the operating range of  $Q$  and  $H$  is represented by a series of contours on a nomograph, called **hill chart**, expressing  $\eta_T$  as function of **head, flow, runner blade angle, and power output**.
- Each turbine model achieves its theoretically optimal efficiency for a unique combination of  $Q$  and  $H$ , which are referred to as **rated flow** and **rated head**.
- The combination of  $\eta_T(Q, H_n)$  with the **head loss formula** of the conveyance system,  $H_n = H - \Delta H(Q)$ , dictates the feasible range of operation of the turbine, and allows determining:
  - the operating point of the system (combination of  $Q$  and  $H$ ) and its efficiency, for a given blade angle;
  - the required blade angle to pass a specific flow  $Q$ .

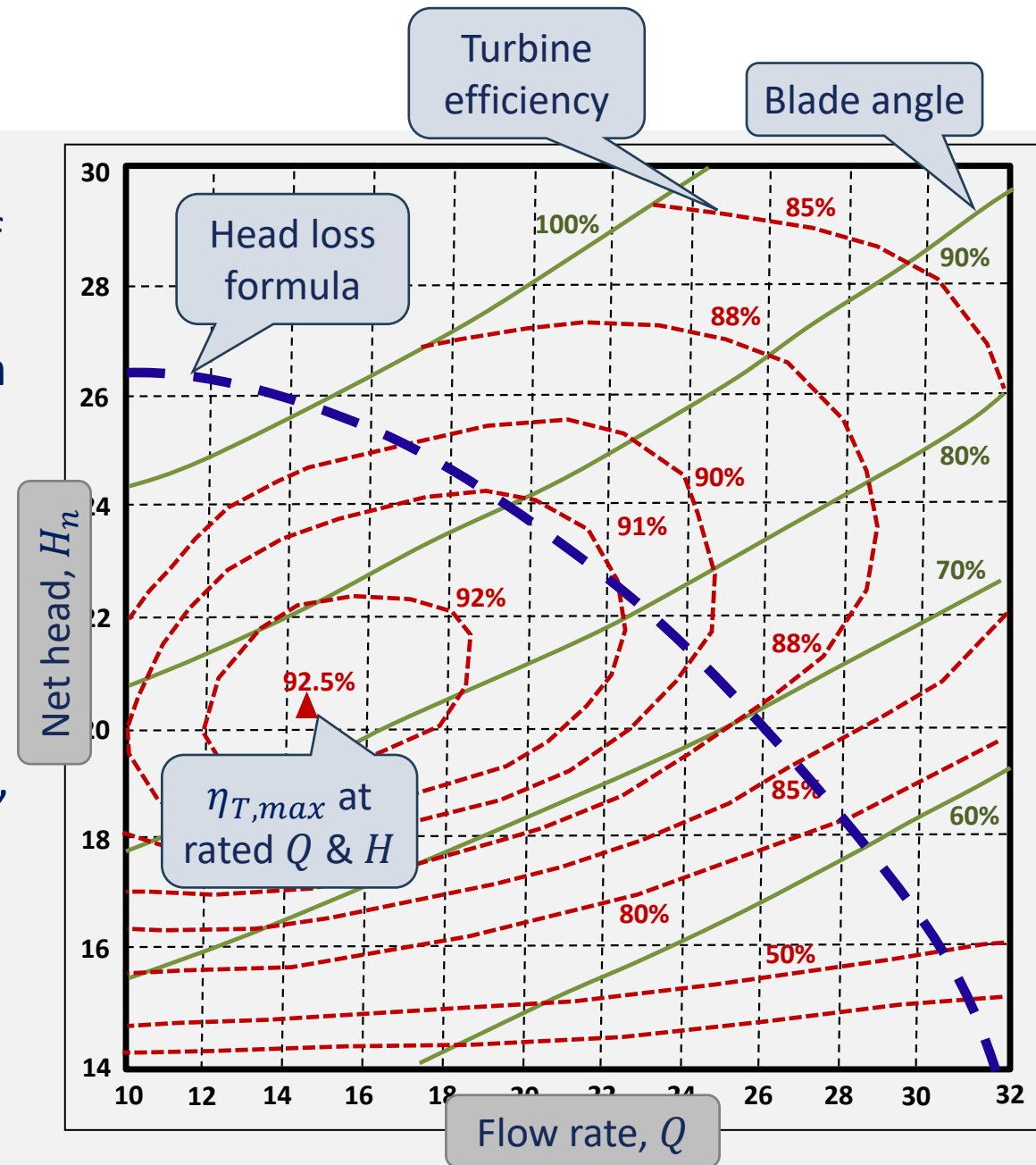



# Remarks on turbine efficiency

- ❑ Rated efficiency increases as the size of the turbine (e.g., diameter runner) increases (**scaling law**).
- ❑ The efficiency curve for specific turbine types is usually expressed by means of nomographs, as **percentage of actual to rated flow**.
- ❑ Nomographs are provided by the manufacturer, and they are obtained by a **reduced scale model**. Since it is not possible to exactly preserve dynamical, geometrical, and kinematical similarity between the lab model and the prototype, it is also not possible to precisely estimate efficiency.
- ❑ Although empirical corrections are employed to better reflect the prototype performance, **actual efficiency** is unknown, since it also depends on technical and operational characteristics of the power plant **in the field**, as well as on deterioration, damage and aging of the equipment over time.
- ❑ Pelton, Crossflow and Kaplan machines retain high efficiency even when running below their rated flow; in contrast the efficiency of Francis turbines falls away sharply below half its rated flow.
- ❑ **Hydroelectric reservoirs** can systematically operate close to their rated head and flow (since the water released to turbines is controlled), thus ensuring high (and practically constant) efficiency.
- ❑ The impacts of varying efficiency are much more important in the case of **small hydroelectric plants**, in which the flow entering the turbines is not regulated due to the absence of storage capacity.

# Efficiency curves of various turbine types

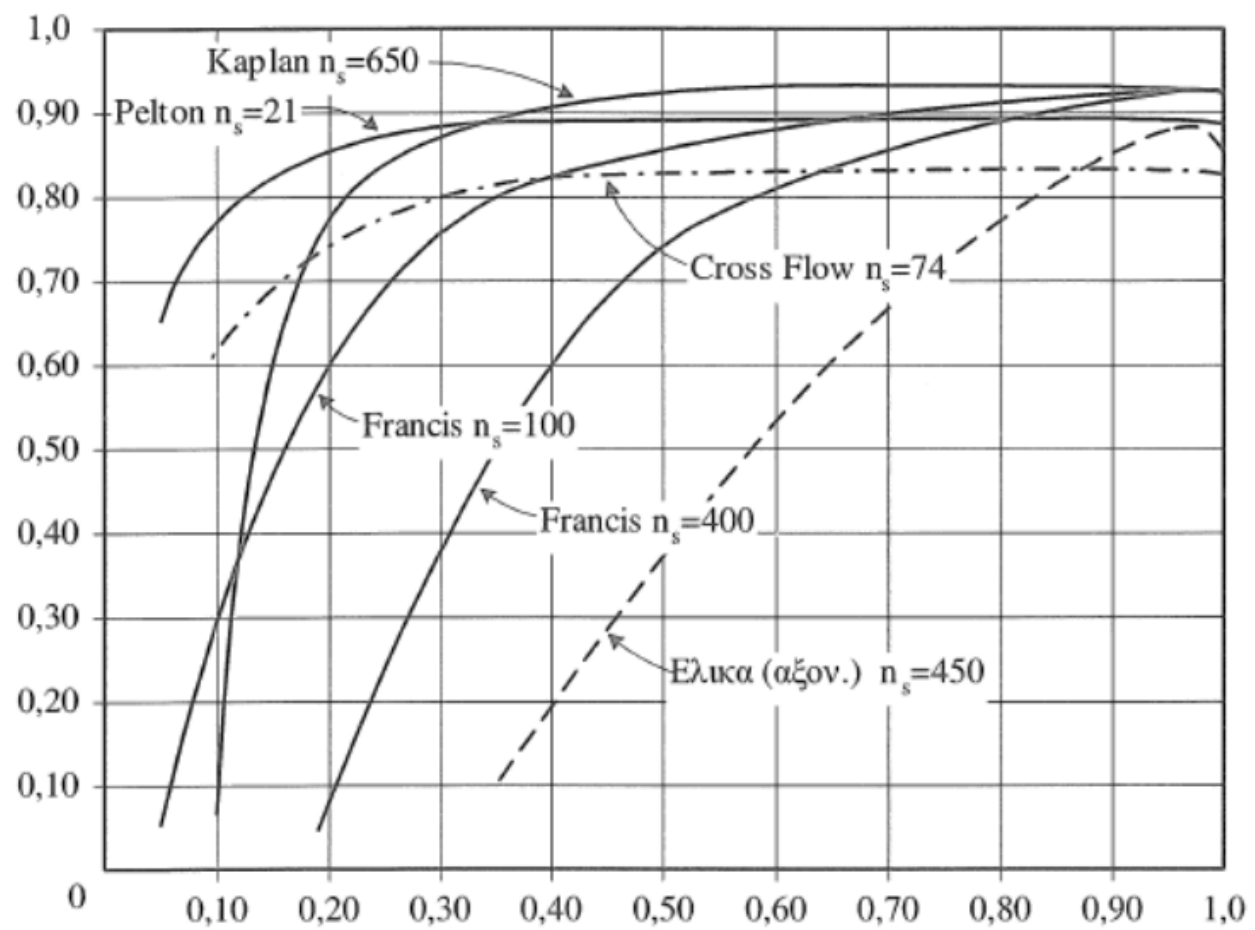
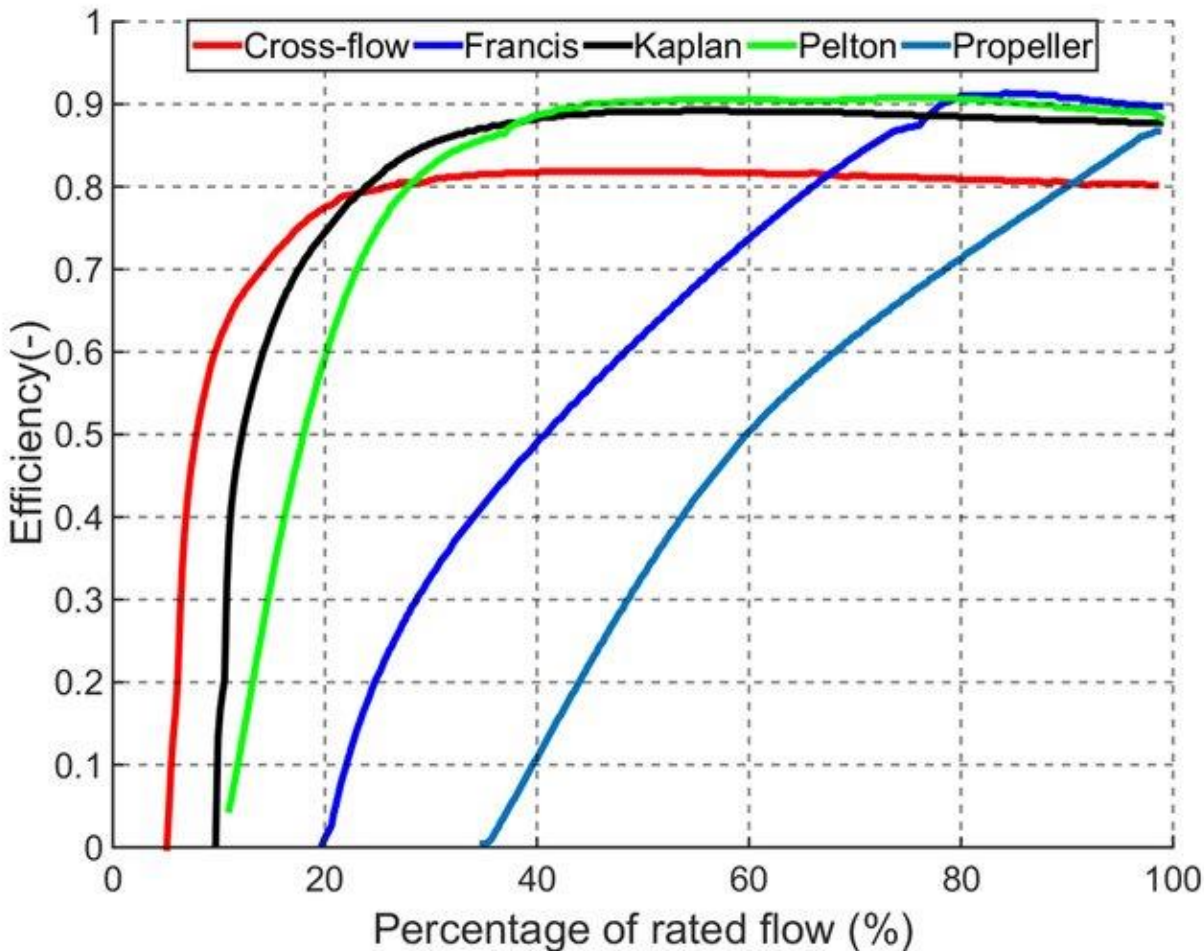

**Remark:** For all turbine types, there exists a minimum flow percentage, below which the system is set out of operation (10-20% for **Pelton**, 40-50% for **Francis**, to protect turbines against cavitation).

# Analytical expression of efficiency

- Generalized formula for turbine efficiency,  $\eta_T$ , as function of dimensionless discharge,  $Q/Q_r$ :

$$\eta_T(Q) = \eta_{min} + \left( 1 - \left( 1 - \left( \frac{Q/Q_r - Q_{min}/Q_r}{1 - Q_{min}/Q_r} \right)^a \right)^b \right) (\eta_{max} - \eta_{min})$$

where  $\eta_{max}$ ,  $\eta_{min}$  are the upper and lower efficiency values within the feasible flow range, namely the minimum value  $Q_{min}$  and the rated one  $Q_r$ , and  $a$  and  $b$  are shape parameters, that are fitted to the specific empirical curve.

- For flow values that exceed the rated flow  $Q_r$ , a similar formula can be applied, by expressing  $\eta_T$  as decreasing function of  $Q/Q_r$ .
- The total efficiency is estimated by multiplying by a reduction coefficient of order of 0.95, to account for the rest of electromechanical losses.

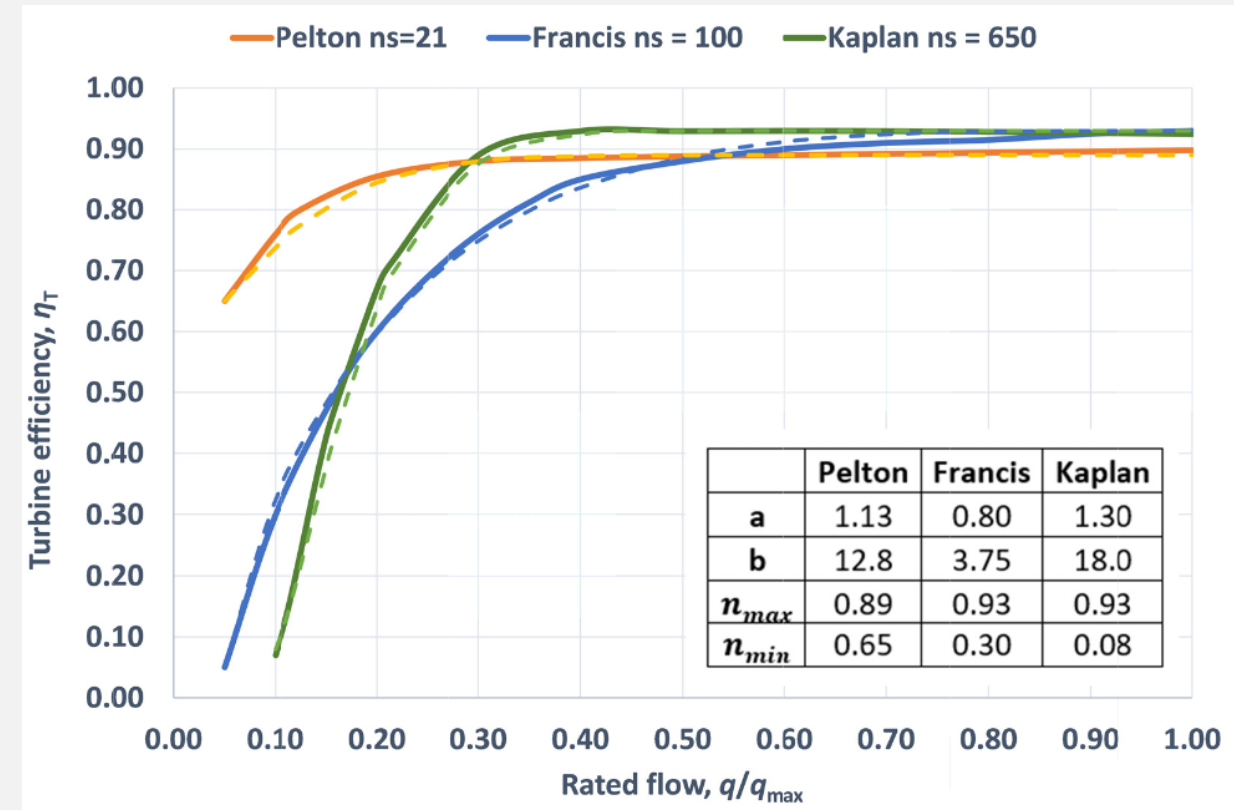

# Flow and efficiency regulation

- ❑ A **flow regulator** inside the turbine allows its performance curve and the associated curve of the pipe losses for matching each other and guarantee an efficiency always close to its maximum value. For negligible hydraulic losses, this is equivalent to keep a constant hydraulic head for all feasible flows.
- ❑ The regulation is made either with hydraulic or electrical means. The **hydraulic regulation**, which is often more flexible and efficient, depends on the type of turbine (needle stroke for Pelton, adjustable guide vanes for Francis, fixed or adjustable guide vanes or adjustable runner blades for Kaplan).
- ❑ Pelton turbines can have multiple needles, which can be set in on/off position, according to the available flow.
- ❑ A high part-flow efficiency can be maintained at less than a quarter of full flow by the arrangement for flow portioning. At low flows, the water can be conveyed through either two-thirds or one third of the runner, thus sustaining a relatively high turbine efficiency.

