

# INTERNATIONAL SOCIETY FOR SOIL MECHANICS AND GEOTECHNICAL ENGINEERING



*This paper was downloaded from the Online Library of the International Society for Soil Mechanics and Geotechnical Engineering (ISSMGE). The library is available here:*

<https://www.issmge.org/publications/online-library>

*This is an open-access database that archives thousands of papers published under the Auspices of the ISSMGE and maintained by the Innovation and Development Committee of ISSMGE.*

## DEEP EXCAVATIONS AND TUNNELLING IN SOFT GROUND

## EXCAVATIONS PROFONDES ET CONSTRUCTION DE TUNNELS EN TERRAINS DE FAIBLE RESISTANCE

Chairman/Président: O. MORETTO (Argentina); General Reporter/Rapporteur Général: R. B. PECK (U. S. A.)

Members of the Panel/Membres du Groupe de Discussion:

J. ALBERRO (Mexico)

M. ENDO (Japan)

J. E. JENNINGS (South Africa)

T. KUESEL (U. S. A.)

W. H. WARD (England)

Chairman O. MORETTO (Argentina)

As all of you know the session of this morning is related to deep excavations and tunneling in soft ground. This is a debut, because the subject is discussed for the first time in an International Conference, as far as I have used the word "début" comparing it with the slang utilized in the world of spectacle, I would say that is a "world début" in particular related to tunnels in soft ground.

Probably many of you who had the opportunity to read the report of our General Reporter, when finishing your reading had reached to the same conclusion of the speaker; the systematization and ordering of the data are so well realized, that although becomes in disagreement in many aspects with the final evaluation, by the way of the enthusiasm one could let carried out, and classified the work in the following way "And from the chaos becomes the light".

Following the same road, I do not think I am exaggerating to much by saying that with respect to tunnels, such a report will make a land mark in the soil mechanics history, it will be a "Before and After" but not only that, it will be a "Before and After" appeared just in the right time and here I can't do less than praise without restrictions to the "Mexican Organizing Committee" for his vision in choosing the subject and for his success in the appointment of the man who composed it.

With the extraordinary increment in population and in vehicles that have been under going the greatest cities of the world the subway construction either in tunneling or in open cuts excavations as well as other type of tunneling for utilities, is passing thorough, an uncommon period of prosperity with special wideness and profit to the subjects which to day attract our attention, from which the one related to excavations forms that we would call the classic section of our knowledge. For that reason nothing is better that this up to date of our knowledge corresponding to today's session.

For it's development the session will be di-

vided in two parts, in the first one our General Reporter will make a summary of his well done work over the "State-of-the-Art" in tunneling construction in soft ground. Following it, will be corresponding summaries of those members of the panel which have been prepared. Contributions over tunnels, included the one of the chairman of this session, which I anticipate to you is characterized to be what in Argentina we call a "metido". The first part will end with an interchange of ideas between the members of the panel on the points that for disagreement will need to be classified. Finished this first part there will be a 10 minutes break, sharp, I make special mentions on the word sharp, because we will be very strictly on that.

The second part will be develop in a similar way to the first one. During this 15 minutes break, the table will receive questions about both subjects, this means Tunneling and Open Cut Excavation, which the General Relator, together with the Panel Members, will try to answer.

Only is previewed the incoming of the audience in the measure of the remaining time allows it. If there would be any possibility, surely we will be forced to make and involuntary but strictly selection. Whatever be done, we exhort all people who want to make any contribution, to do so by writing, following the prescribed procedure by the Organizing Committee.

I think it would be petulant of my own to introduce you the General Reporter, who is well known, in spite of that I pass the word to Dr. Ralph B. Peck, Professor of the University of Illinois in the United States and elected President of the International Society of Soil Mechanics and Foundation Engineering.

General Reporter R. B. PECK (U. S. A.)

Prof. R. B. Peck's State-of-the-Art report appears on pp. 225 of the State-of-the-Art volume.

Chairman O. MORETTO

Thank you very much Dr. Peck for a significant summary of the first part of your general report.

The first contribution from the panelist, will be in charge of Mr. T. Kuesel, member of the firm Parsons, Brinckerhoff Quade & Douglas of New York.

Panelist T. KUESEL (U. S. A.)

## SYNOPSIS

Experience on the construction of 14 miles of soft-ground tunnels and six large subway station excavations has been accumulated on the BART project. This paper covers the bases of design, construction methods used, and field observations on movements, distortions, and effects on existing structures.

### Scope

The San Francisco Bay Area Rapid Transit System (BART) comprises 75 route miles, including 13 miles of cut-and-cover and tunneled subways in San Francisco, Oakland, and Berkeley. All tunnels are single-track sections, approximately 18 feet in diameter. There are 15 tunnel contracts, including 42 individual drives with a total length of 14 miles. Usually there are two parallel tunnels at the same level, but under Market Street in San Francisco there are four tunnels (two over two), and there is also a three-track section (two over one) in Broadway, Oakland. At present writing (July 1969), 27 tunnels comprising 10 miles have been completed.

### Soil Conditions

Simplified soil profiles along Market and Mission Streets in San Francisco are shown in Fig. 1. The predominant stratum on Market Street is a dense, fine, slightly cohesive sand. A large wedge of soft, plastic clay intrudes near the shoreline, and scattered lenses of peat are encountered around the Civic Center Station. On Mission Street, the interfingering granular and cohesive alluvial deposits are moderately consolidated, but occasional pockets of compressible materials are encountered, as well as several pinacles of weathered serpentine and sandstone rock. Tunnels lie as much as 50 feet below the groundwater table. In Oakland and Berkeley, the soils are all alluvial, and fall generally within a classification of moderately firm, cohesive granular materials.

### Use of Tunneling Machines

BART specifications require shields on all tunnels, but leave excavation methods to the contractors. For the four tunnel contracts in Oakland and Berkeley, the individual drives were all under 1,500 feet long, and construction schedules were generous. These tunnels

have all been hand-excavated. On six of the 11 San Francisco tunnel contracts, including all drives longer than 3,000 feet, mechanical excavators are being used.

The machines have performed well in the dense sands and the cohesive granular soils, and have successfully negotiated short lengths of soft clay and weathered rock encountered on Mission Street. No running or flowing ground was encountered.

Most of the machine-excavated tunnels would be classed as potentially ravelling ground. The machines generally have closed faces with narrow slots or doors through which the soil is taken in as it is scraped off the face. This permits supporting the face through the machine's thrust jacks. Nonetheless, in the early operations a serious cavity developed above one tunnel, which was traced to a failure to keep the advance of the machine equal to the volume of soil excavated.

### Use of Compressed Air

Mandatory compressed air was specified on six contracts, generally where dewatering might consolidate compressible soil layers. Partial dewatering was permitted in a number of cases. In Lower Market Street, compressed air was used to reduce the movement of soft Bay Clay into the heading. A pressure of 12 psi reduced the value of  $N = \gamma H/S_u$  from about 6 to below 5.

### Surface Settlements

With isolated exceptions, all tunnels have been driven with a prevalent surface settlement not exceeding two inches, and usually less than one inch. The greater part appears to be widespread settlement associated with groundwater drawdown. Settlement attributable to loss of ground is generally less than one inch over the tunnels, and for tunnels in the center of the street, the settlement along the building lines is negligible.

As a general exception, there is almost invariably greater settlement at the start of a tunnel drive. This occurred with almost all contractors, types of ground, equipment, and methods, owing to a lack of team experience with the particular combination of circumstances represented by that tunnel. Local settlements of three inches were not uncommon at starting areas - some cases reached 8 inches. Among conditions contributing to exceptional settlement were:

1. Tunneling under street intersections repeatedly disturbed by utility relocations.
2. Experimentation with new grouting materials, and new shield tail sealing systems.
3. Vibrations from air compressor plants.

Soil arching over the first tunnel frequently limited initial settlement to very minor amounts. Driving a parallel tunnel generally dislodged the arch-eventual

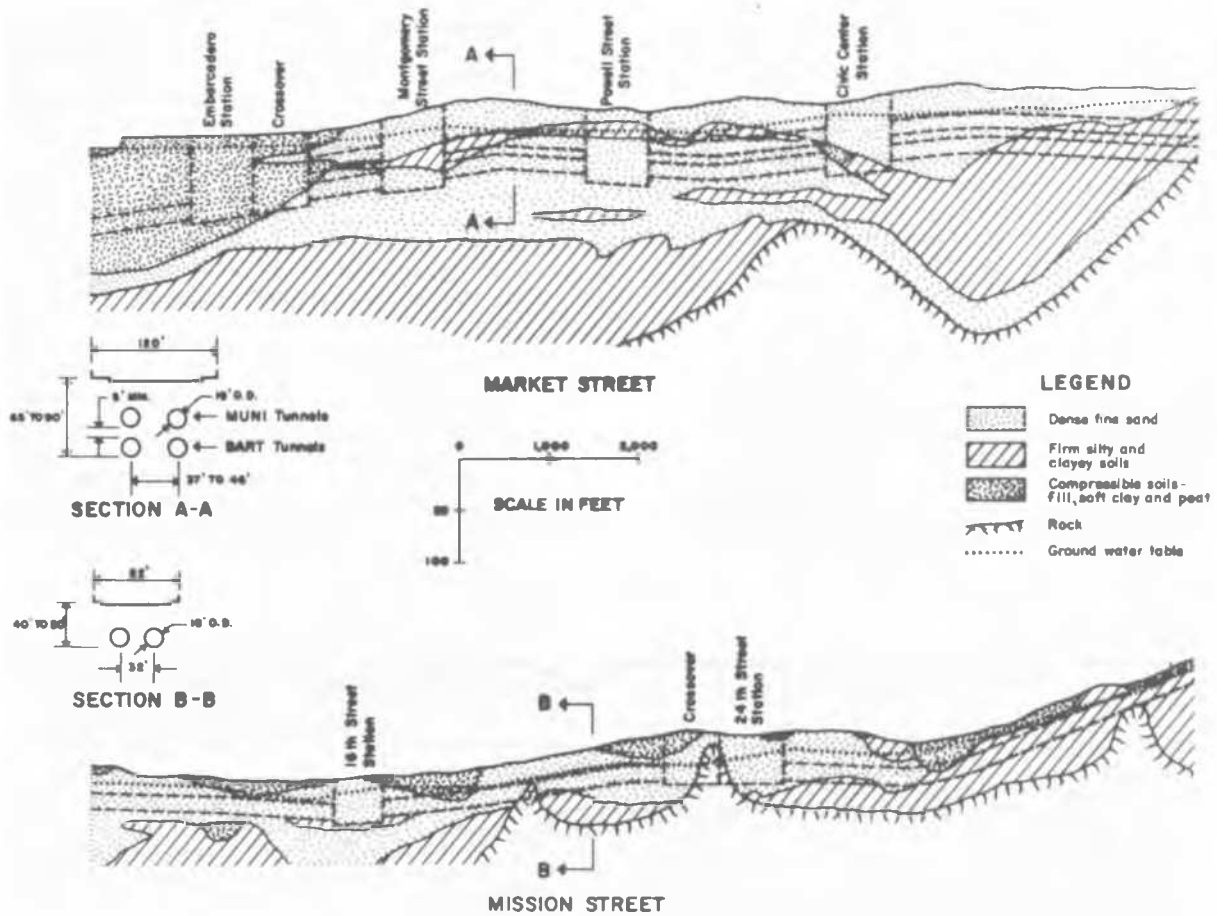

Fig. 1 - Soil Profiles - San Francisco Subways

settlements over both tunnels were comparable.

Figure 2 shows the configuration of the three-tunnel section in Oakland, as well as surface settlement profiles measured over each tunnel as it was driven. The large settlement at the start of Tunnels No. 2 and No. 3 represents the effects of a tieback anchor in soil that pulled loose in the shield starting pit. (By fortune or foresight, the adjacent buildings had been underpinned.)

Figure 3 shows two cross sections of the first tunnel contract in Market Street (the two upper level tunnels had not been started at the time of writing.) The first section is typical of conditions where relatively large settlements (2 inches or more) were encountered, and shows the effects of initial excavation, continued settlement until grouting is completed, and the passage of the adjacent tunnel. (In this tunnel, pea gravel was injected into the tail void as the shield was jacked forward, followed by grouting approximately a week later.) The second section represents much more prevalent conditions, in which total settlements were a fraction of an inch.

Generally greater settlements were observed on Lower

Market Street, in soft Bay Clay. Three inches is a prevalent value, with some cases up to 6 or 8 inches. The difficulty was not so much the weakness of the soil, but rather the presence of nearly 1,000 buried timber piles remaining from abandoned wharves and foundations. These were cut off in front of the shield, and air pressure was limited to avoid blowing chimneys out along the piles. Some pile stubs remaining above the shield invert plow were pushed over when the shield was jacked, remolding the clay beneath the tunnel.

Effects on Existing Structures

There has been no significant differential settlement under buildings along the tunnels. (On Lower Market Street most of the buildings had been previously demolished for an urban redevelopment project, and the principal remaining ones are on piles.) There are no significant claims outstanding for building damage—a typical complaint is that a door sticks. Many notable cases of nonsettlement have been recorded. Among them:

1. An eight-story reinforced concrete Bank of America building; containing automatic machi-

SEANCE PLENIERE 4

- nery for processing all of the bank's checks, rests on spread footings on dense sand. A tunnel was driven directly in front of and 40 feet below six 1,200-ton footings, with a minimum horizontal clearance of less than four feet. A closed-face tunneling machine was used, with 12-psi air pressure, and ring-by-ring neat cement grouting. No protective construction was undertaken for the building, other than instrumentation and careful control of tunneling. Measurements showed that the passage of the tunnel caused the building to rise 1/8 inch.
2. A telephone switching station was located in an old brick-walled steel frame building that had survived the 1906 earthquake imperfectly. Cables had been installed to tie the building together across the old cracks. Spread footings on dense sand were located 40 feet directly over the tunnel crown. The tunnel was machine-driven without visibly enlarging the existing cracks.

3. The footings of a three-story wood frame apartment house lie 15 feet directly above a tunnel in moderately firm silty sand. The building was not underpinned. None of the residents were evacuated, nor were any of them awakened the night the tunnel machine passed beneath.
4. A thriving hardware store occupies a building constructed on top of the remains of several previous buildings demolished by fire. The structural support for part of the first floor consists of deeply charred wood beams resting on piles of loose bricks roughly approximating columns. Despite a recommendation to demolish the structure, it was decided to leave it in place, only strapping the loose bricks together, while two tunnels were driven directly beneath the basement floor, one with a soil cover of only seven feet above the crown. This was the last tunnel driven in Oakland, and benefitted from the experience of an exceptionally able tunneling crew and foreman. Using an open-face shield and hand mining and face-support

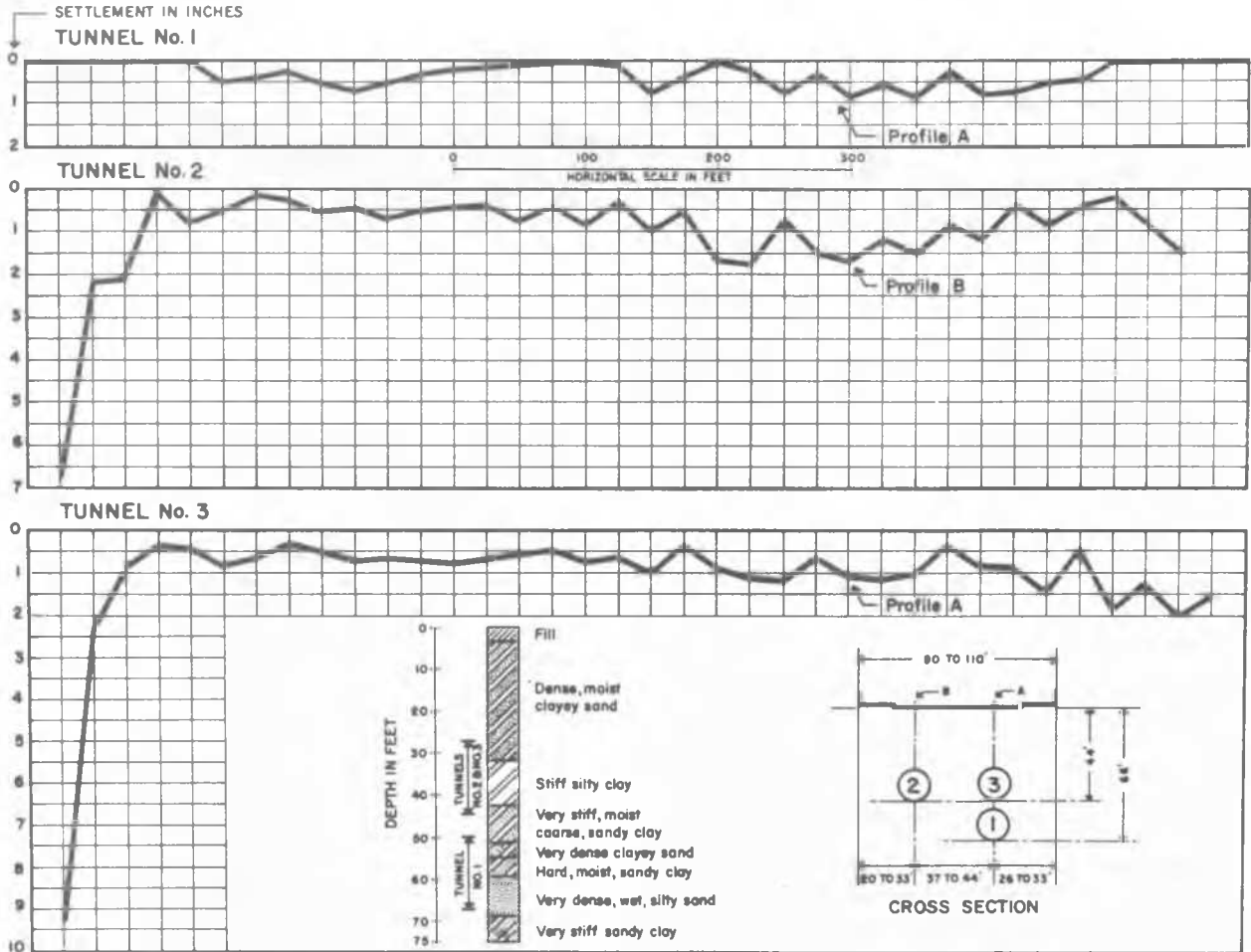

Fig. 2 - Broadway-Oakland Tunnels - Surface Settlements - measured after completion of each tunnel drive.

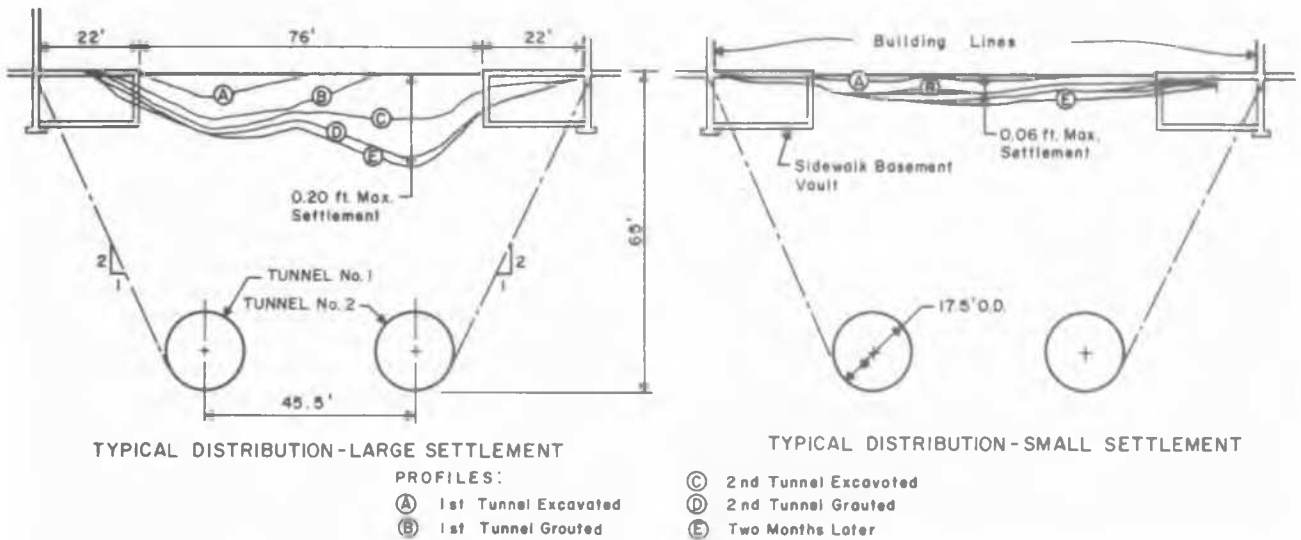

Fig. 3 - Transverse Settlement Distribution - Market Street Tunnels

methods, the tunnels were driven through a cohesive, compact sand, without incident. The upper tunnel was dewatered and the lower tunnel used compressed air. The charred beams and loose bricks are still there.

Along Market Street, many of the steel-framed buildings adjacent to the tunnel route have had "column pick-up" jacking setups installed as a precautionary measure. Although only two of the lower level tunnels have been driven, none of the jacking installations has been activated, and experience to date indicates that none will be unless there is an accident.

The most prominent underpinning effort involved the Ferry Building, a historic San Francisco landmark at the foot of Market Street, which bestrides the tunnels with a forest of timber piles. Working from within the building, steel pipe piles were jacked down alongside the tunnel alignment, and capped with prestressed concrete beams spanning across the tunnels. The building loads were then transferred to the new foundations, permitting cutting off the old timber piles as they were encountered in the tunnel heading. Although these piles posed a considerable obstruction to tunneling, their removal caused no damage to the underpinned building.

An unusual precaution involved a 30-foot-diameter cistern 18 feet deep, one of many placed beneath San Francisco streets after the 1906 earthquake as an emergency reservoir, and still filled periodically by the fire department. To forestall any possible leaks due to ground movements, the cistern was drained. However, with no cover other than the street pavement, and only 15 feet between the bottom of the cistern and the tunnel crown, the empty cistern provided insufficient weight to contain the tunnel air pressure. It was "overpinned" by pumping 70 cubic yards of concrete into it, and thereby avoided the distinction of be-

coming the first flying cistern in San Francisco.

Tunnel Liner Design

BART tunnel liners consist of fabricated steel segmental rings, bolted together to form a uniform structural tube stiffened with 6" deep ribs about 2'6" on centers both ways. Each ring consists of six welded pan sections 2' 6" wide by about 9' 6" long, plus a short tapered key section to facilitate erection.

The design is based on the flexible ring concept, with sections proportioned to carry (at normal working stresses) the uniform ring compression corresponding to full overburden pressure, plus the bending stress resulting from a shortening of the vertical diameter (and corresponding lengthening of the horizontal diameter) of 1/2 inch ( $\Delta D/D = 0.25\%$ ). The bending stresses are calculated for a theoretically unjointed and fully elastic ring, and comprise approximately 80% of the calculated stress. Consideration of the effects of the segment joints and of the bolt hole clearances indicates that the ring is actually much more flexible, and can absorb several inches of deformation elastically. The large ductility of steel also gives the rings a substantial plastic deformation capacity while continuing to support external pressures.

Tunnel Liner Distortions

A survey of 4,647 rings in the ten Oakland tunnel drives, made at the time the rings were erected in the shield, shows that in 48% of the rings the diameter distortion was within 0.25% of the original diameters, and in an additional 25% of the rings, within 0.50%. Five percent of the rings showed up to 1.0% distortion, and 1% of the rings exceeded 2% distortion.

Subsequently, the three Oakland tunnels shown on

Fig. 2 were checked by measuring vertical, horizontal, and diagonal diameters on everytenth ring. Five rings in Tunnel No. 1 were measured shortly after erection, when the shield tail void had been packed with pea gravel, but before grouting. In all five rings the horizontal diameter increased one to two inches (0.5 to 1.0%).

A total of 123 additional rings were measured from two weeks to four months after erection and grouting. In 60% of these rings, the change from erected diameter was less than one-half inch (0.25%) in 30% of the rings up to one inch (0.50%), and in 10%, more than one inch, up to two inches (1.0%) maximum. In the grouted rings of Tunnel No. 1, the horizontal diameter generally shortened (in contrast to the ungrouted rings). The two upper tunnels were randomly mixed. The diagonal diameters frequently showed more distortion than the vertical and horizontal diameters, generally up to 0.75%, but there was no consistency of direction.

It may be inferred that the tunnel tends to squat until it is grouted, and that the process of grouting introduces random, unpredictable distortions. Since the greatest quantity of grout is frequently injected near the spring lines, the initial squat may be reversed.

No observations were made of the effects of passing adjacent tunnels, but in the generally firm ground of the BART system the effects have not been casually noticeable.

In Lower Market Street, in soft Bay Clay studded with old timber piles, more general distortions of two inches (1.0%) have been recorded with sporadic cases of three to four inches (1.5 to 2.0%). This has required some recaulking, but has produced no evident structural distress.

#### Miscellaneous Tunneling Effects

On some 20,000 rings erected to date, only two buckling failures have occurred. These were encountered in a tunnel driven through exceptionally firm sand, and were attributed to excessive unbalanced grouting pressure (several times the design overburden pressure) inadvertently introduced into the annular shield tail void.

The two buckled segments were cut out, removed, and replaced with new segments. The soil was firm enough to arch across the opening without additional temporary support. The longitudinal precompression induced in the tunnel liner by the shield jacks caused the adjacent rings to squeeze slightly into the opening, so that the new segments did not fit, and considerable difficulty was experienced in forcing them into place.

At the foot of Market Street, twin tunnels are driven through soft Bay Clay and a special clay fill into a steel collar plate attached to the end section of the Trans-Bay Tube, about 400 feet offshore. A temporary grout seal was made between the tunnel rings

and the collar plate while the shield jacks were still pressurized. When the jacks were released, the tunnel moved longitudinally 3/16 inch and cracked the seal, requiring regrouting.

#### Deep Excavations

The cut-and-cover sections include 18 subway stations, of which six are located in the 3- and 4-track sections and involve excavations up to 70 feet deep, 65 feet wide, and 800 feet long. Five of these deep stations are in predominantly cohesive/granular materials and are well advanced. The sixth (Embarcadero) is located largely in the soft Bay Clay of Lower Market Street, where construction is in an early stage.

These stations are up to 60 feet below the groundwater table. To resist the hydrostatic uplift pressure, which may aggregate 100,000 tons on a station, the walls and invert slabs are made of concrete, three to seven feet thick. As shown on Fig. 4, an internal structural steel framework braces the exterior concrete shell. Concrete interior floor and roof slabs complete the structural system.

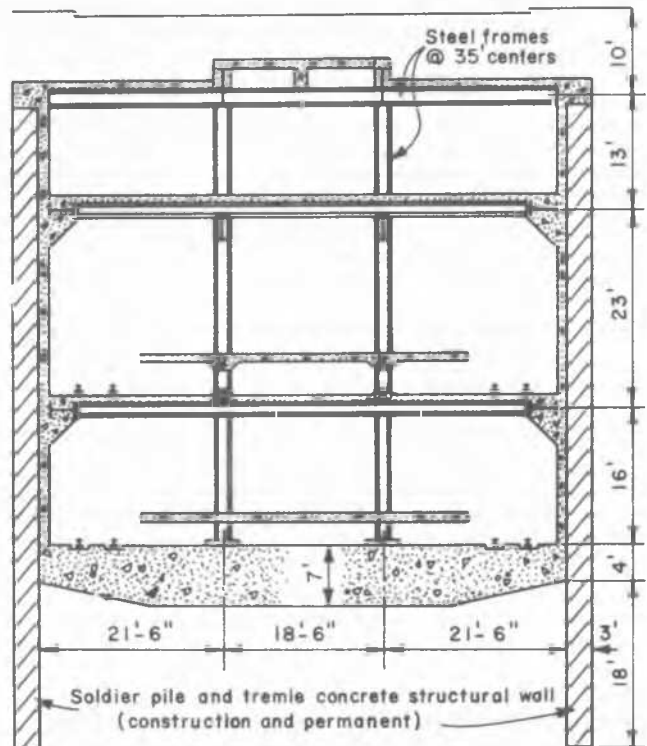

Fig. 4 - Typical Section - Market Street Subway Station

The permanent structural steel frame is designed to be utilized during construction for support of the excavation. In addition, temporary struts are required to limit the depth of unbraced excavation below the deepest installed bracing level to 15 feet. After the

concrete invert slab has been installed, removal of the temporary struts is permitted. This combination of requirements provides maximum support of the bulkhead walls during construction, minimum quantities of temporary materials, and reasonable construction working space.

Types of Excavation Support

Two basic types of bulkhead wall construction are used. In the first type, the wall is designed by the contractor (within design requirements established by the engineer) and is not considered as part of the permanent structure. Generally, this has resulted in steel soldier piles, spaced at six-foot centers, with wood lagging spanning between the piles, and external dewatering systems consisting of eductors or deep-well pumps.

The second type of bulkhead wall is designed by the engineer as part of the permanent structural wall. It consists of steel soldier piles with the spaces between them filled with tremie concrete, and is designated the "SPTC wall." The piles are installed in undersized, slurry-filled augered holes, so that the flanges of the piles are in direct contact with undisturbed soil. The spaces between the piles are then excavated, the resulting slot being kept filled with bentonite slurry. This slurry is then displaced by tremie concrete to form the completed wall.

The introduction of the steel piles into the concrete wall promotes control of vertical plumbness, facilitates connection of the permanent interior structural framework, provides improved security of the slurry-filled trenches against seismic shocks, and eliminates all reinforcing steel.

The concrete bulkhead wall provides an impermeable cofferdam which can be excavated without drawing down the groundwater table outside the wall. The differential head between the water levels inside and outside requires special provisions for control of seepage beneath the wall and hydrostatic uplift pressures on the base.

The "SPTC wall" was specified for two of the deep stations (Civic Center and Embarcadero), where presence of compressible soils precluded external dewatering. It was made optional for the other four stations, but was chosen by the contractor only for one (Powell Street), where the bulkhead walls had to be installed with less than four feet clearance from the basement walls of two busy stores.

At one end of the Embarcadero Station, the depth of fill and soft Bay Clay approaches 90 feet, while the depth of excavation will be 65 feet. The piles and tremie concrete walls are toed into firm sand and dense clay layers beneath the soft clay to secure lateral support. The most critical stage of the work occurs at an early stage of excavation (see Fig. 5) when only the upper levels of internal bracing have been installed, and the unexcavated soft clay provides negligible

lateral support owing to its small modulus of deformation. This requires specially fabricated welded H-section piles up to 5 feet deep, at 6-foot centers, with sections weighing as much as 600 pounds per foot. Individual soldier piles weigh as much as 30 tons each. Even with these extraordinary sections, it is anticipated that lateral inward movements of the wall of several inches may develop.

Consideration was given to underwater excavation methods and to installation of cross-lot diaphragms in advance of general excavation. These methods would add a substantial cost premium, and the selected method is satisfactory so long as adequate lateral support of the toe can be developed.

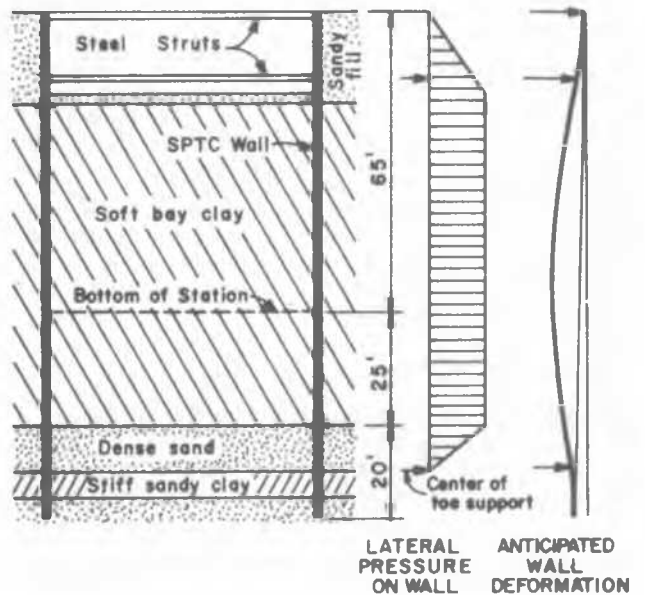

Fig. 5 - Embarcadero Station - Critical Excavation Stage

Instrumentation

Vertical settlements are monitored by surveys of marks painted on existing buildings, sidewalks, and pavements. Some points were installed through pipes driven through the pavement into the underlying soil, to eliminate bridging effect.

Horizontal wall movements are generally measured by means of inclinometers in vertical casings installed immediately outside the soldier piles. On the Civic Center Station, an alternative system of horizontal extensometers was used.

In each station, one or more zones 70 feet wide was established for measuring strut loads, through vibrating-wire strain gauges cemented in pairs to opposite sides of the strut web.

Preloading

All struts are required to be preloaded by jacking at



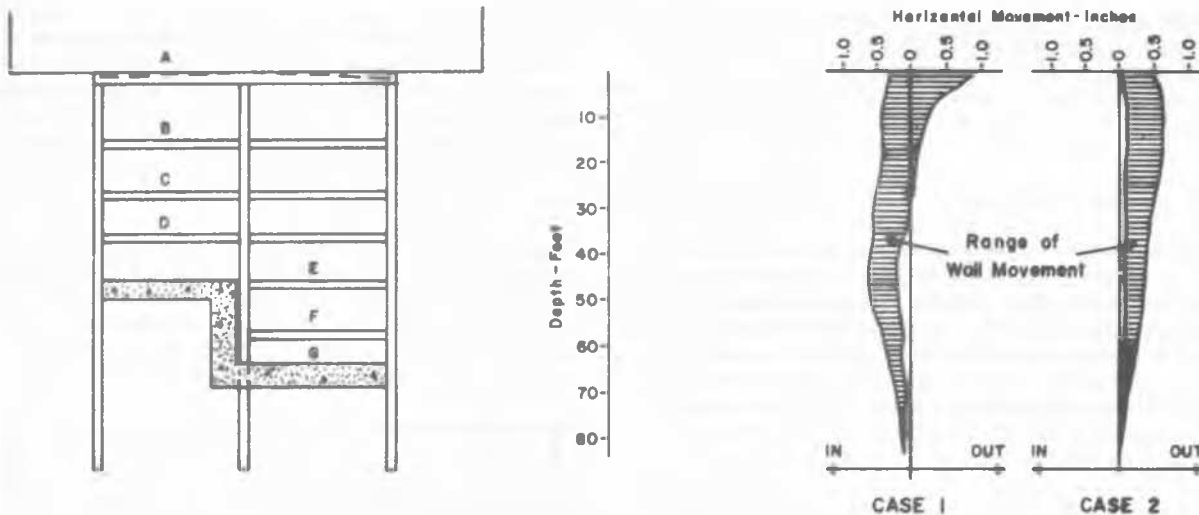

Fig. 6 - Wall Movements from Slope Indicator Readings - 12th Street Station, Oakland

installation. The preload is established by the engineer after review of the contractor's proposed bracing layout, and has generally been about 25% of the design earth pressure load. Struts are required to be shielded from direct sunlight, to reduce effects of temperature changes.

Wall Movements

All available measurements represent construction in dense cohesive/granular soils. Movements are erratic, and apparently influenced by variations in construction technique as much as by variations in soil conditions.

Figure 6 shows two typical patterns of wall movement recorded by inclinometer measurements in one of the Oakland subway stations.

In general, horizontal movements of the bulkhead walls have been kept within one inch without difficulty, and have produced no significant surface settlements adjacent to the walls. No data are yet available on the larger movements expected in the soft clay strata on Lower Market Street.

Surface Settlements

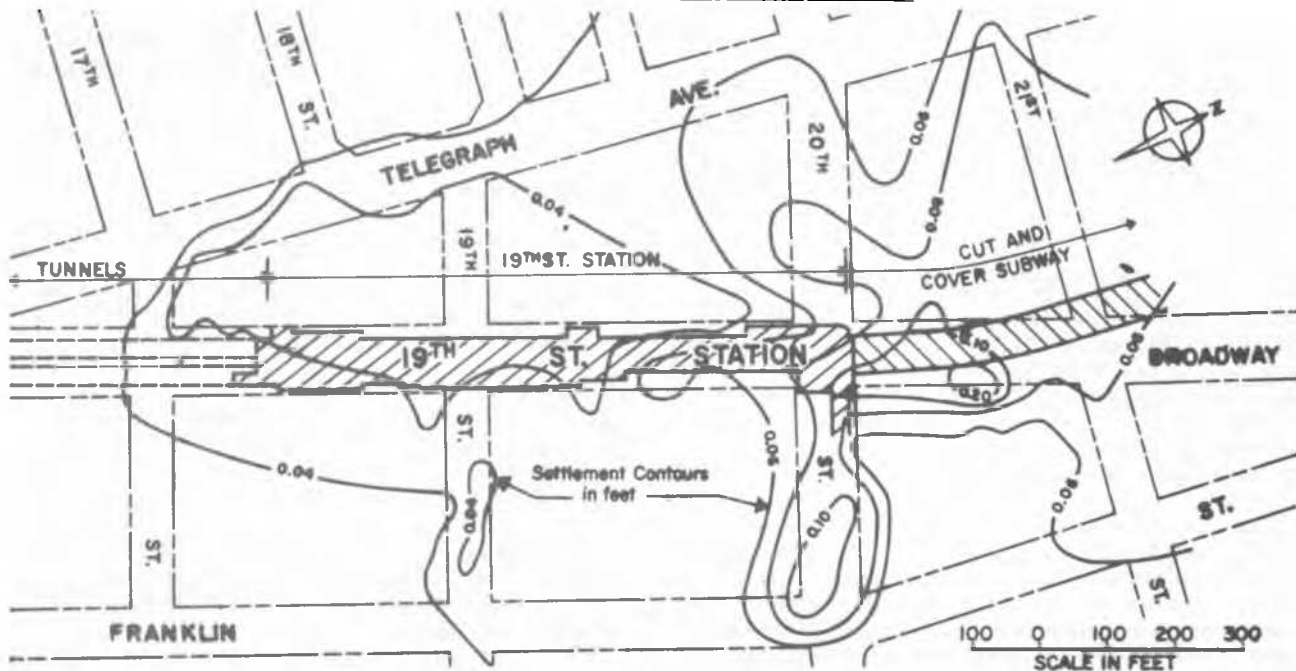

Fig. 7 - Surface Settlements - 19th Street Station, Oakland

Figure 7 shows contours of surface settlement in the vicinity of the 19th Street Station in Oakland, which was constructed with soldier piles, wood lagging, and external dewatering. The locations of large settlements correlate to locations of shallow compressible clay deposits and groundwater drawdown levels. Differential settlements across any one building site are slight, and have caused no significant distress.

The compressible materials are absent from the south end of the site, and the fractional settlements recorded there are typical of those that may be attributed to loss of ground and wall movements.

Strut Loads and Earth Pressures

Design criteria for free-draining soldier pile walls specify a total earth pressure based on  $K_o H$ , with  $K_o$  taken as 0.4 to 0.5, and redistribution of this total pressure into a trapezoidal shape to allow for vertical arching of the relatively stiff soil, and for slight inward movement of the bottom of the wall. For impervious SPTC walls, an allowance for hydrostatic pressures is added.

Strut loads have been measured in cohesive/granular materials. Strain gauge measurements have generally been somewhat lower than the estimated design loads. However, the recorded loads at one strut level (not consistently the same level) frequently approach the design loads. Figure 8 illustrates two typical cases recorded at Montgomery Street Station.

Loads in the permanent struts that are encased in concrete floor slab construction show considerable variation. During excavation, the load increases from the preload value as the excavation deepens. Temperature variations cause the strut to swell and shrink, changing its load. When the concrete slab is

poured, the heat of hydration swells the steel strut and increases its load sharply. This effect dissipates rapidly, but is replaced by concrete shrinkage, which tends to recompress the beam. In the final stage concrete creep produces a gradual relaxation as shrinkage strains are relieved. These effects are considerably more pronounced than any variation in earth pressures, and make any attempt at constructing a final external pressure diagram on the structure an unrewarding exercise.

Effects on Adjacent Structures

Most of the subway station entrances are located in the sidewalks directly in front of existing structures.

Where these entrances required construction below the existing building footings, the footings were extended down to a safe level, generally by means of underpinning piers constructed in sections in hand-excavated pits.

Where soldier pile and lagging construction was used for the deep station excavations, limited precautionary underpinning was generally undertaken. For large, heavy buildings, steel pipe piles were installed in sections by jacking them down against the reaction of the building footing, and then jacking them to a pre-determined load and wedging them into place. Underpinning was limited to the first row of building columns adjacent to the excavation. Approximately 15 buildings adjacent to the three major soldier pile stations, and seven adjacent to tunnel sections, were underpinned by jacked piles, working through the building basements and subsidewalk basement vaults, without serious disruption of use of the buildings and without structural incident. For lighter buildings, "underpinning control piers" were installed in shallow pits under the front column footings, with hollow spaces provided to receive jacks to be used to adjust

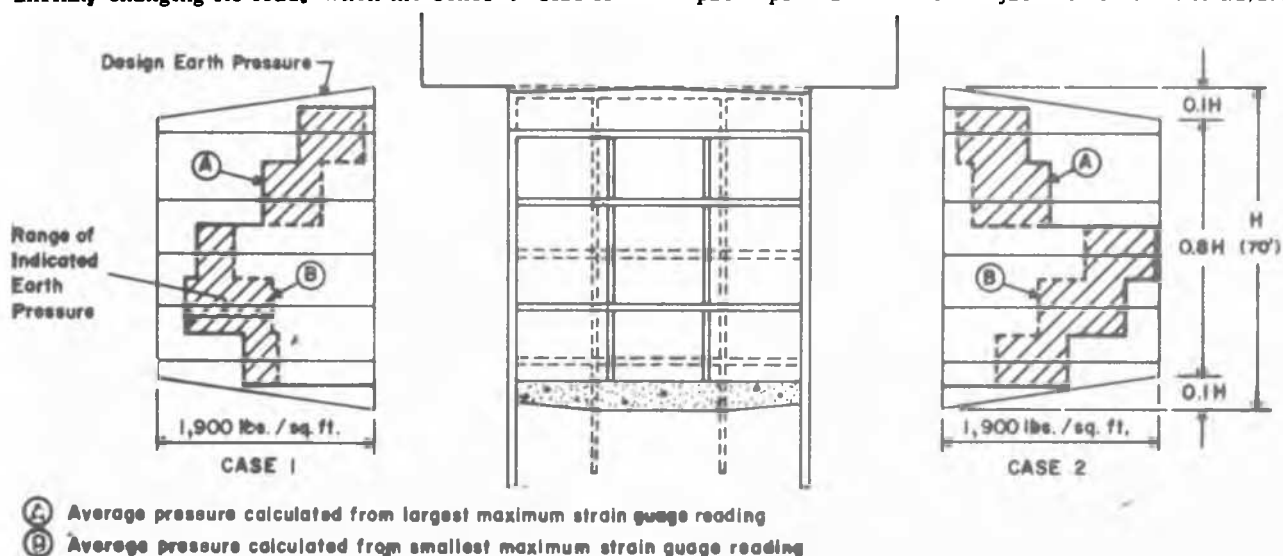

Fig. 8 - Earth Pressures Indicated by Strain Gauge Measurements - Montgomery Street Station

the footing depth if necessary.

Surveys indicate that the process of underpinning has caused the front of a typical building to settle a fraction of an inch. The remainder of the building has generally settled slightly as a result of dewatering effects, and the building has suffered little differential settlement and no significant distress.

Fortunately, most of the deep excavations on the BART project have been located in the better soils. Nonetheless, the successful construction of such large underground structures in close proximity to major buildings without significant damage has been accomplished only with detailed planning and careful control of construction operations, in the light of the particular soil conditions at each site.

Chairman O. MORETTO

Thank you very much for an interesting contribution related with one of the most important tunneling work that has been realized at this moment in all the world.

The next contribution will be in charge of Dr. W.H. Ward, Head of the Geotechnics Division of the Building Research Station of Great Britain Mr. Ward.

Panelist W. H. WARD (England)

## SYNOPSIS

The author comments on Peck's State of the Art paper in respect of tunneling in the light of experiences in London on the yielding of the ground and the structural performance of tunnel linings of different flexibility. New information is provided on these two topics.

## INTRODUCTION

My remarks will be limited to Part A (Tunnelling) of Professor Peck's report on the state of the art in 'Deep Excavation and Tunnelling in Soft Ground'. My experiences in tunnelling are related mainly to over-consolidated stiff-fissured clays, in particular the London Clay where the conditions for tunnel construction are relatively straightforward, but I have also had experiences in water-bearing sand, soft silts and various varieties of soft rocks.

I agree to a large extent with Peck's philosophy and his criticisms of the present state of the art of tunnel design and construction. The cost of construction of tunnels in London is certainly coming down, but this has arisen mainly from improvements in lining design and the elimination of two processes, namely bolting of the lining and grouting, rather than the re-introduction<sup>(1)</sup> of tunnelling machines. Present tunnelling machines are a mixed blessing, while they improve progress when they are operating they are more liable to produce overbreak and if they encounter a buried channel of

water-bearing ground, as happened twice on the Victoria Underground Line North of the Thames, progress is delayed very substantially - so much so that ordinary hand shields have been used more recently on the Victoria Line South of the Thames where buried river channels were expected and encountered.

I entirely agree that the design and construction of tunnels are inseparable. Too often an engineer produces a design for a completed tunnel lining and the process of construction is sorted out by trial and error with an unspecified set of equipment in the course of building the tunnel. The whole endeavour of design and construction needs to be considered as an integrated process, in the same way that a production line in a factory is developed.

## YIELD AND MOVEMENTS AROUND TUNNELS IN LONDON CLAY

Any adverse effects of deep tunnels on overlying and adjacent structures are caused by the yielding that occurs before the permanent water-tight tunnel lining is placed and this is the case even under the relatively ideal conditions in London. As an index of yielding of clay Peck has used the ratio

$$(P_z - P_a) / \sigma_u$$

and Broms and Bennermark have suggested that this ratio should not exceed about 6 otherwise the clay will flow into the face of the shield. On the other hand Peck suggests that if the ratio is much greater than 5 the clay is likely to invade the tail-piece clearance on the shield.

I feel it is necessary to make clear that ratios as high as 5 or 6 are really an index of whether present shield tunnelling procedures are feasible at all without a further increase in the ambient pressure within the tunnel. This criterion means that it is absolutely necessary in all tunnels of any depth in normally-consolidated clays to apply quite substantial pressures continuously to the face (e.g. by air) to prevent considerable influx of the ground. This simple fact is not as well known as it should be. At such large recommended ratio values the yield of the ground cannot be under any real control with present construction procedures and movement of the ground can be quite disturbing so far as overlying and adjacent structures are concerned. Moreover the value of the ratio which causes a given volume of plastic yield of the clay in a tunnelling operation

(1) A tunnelling machine similar to the modern one was used in the construction of the Northern Line of the London Underground before the end of the last century. I believe its use was discontinued because of the advent of the pneumatic spade which enabled excavation to proceed in step with the rate of lining construction.

depends very much on the detailed geometry of the unsupported or partially supported areas of the ground and the duration of lack of support before the permanent lining is erected.

As a first step when considering the construction of a new deep tunnel in clay in a new area I prefer to consider yielding as commencing at a pressure-shear strength ratio of about 1, which is the value one obtains theoretically from simple elastic considerations of a cylindrical hole in a uniform stress field. If the ratio is of the order of 1 or perhaps 2 it means that excavation can be carried out fairly freely ahead of the lining and that the short-term ground movement can be only of a small elastic nature. This is normally the case in deep tunnels at depths in common use in London Clay. Although a shield is frequently used in London in these circumstances we have no evidence to suggest that its use reduces ground movements to any appreciable extent. Short lengths of tunnel are often built without a shield and without an obvious increase in ground movement. Rather the shield is a convenient device for trimming the hole to a reasonably circular shape and for protecting the miners from occasional falls of blocks of clay from the roof. Even when a shield is used a length of about 2 feet of ground is often exposed behind the tail to construct the ring of permanent lining and sometimes several rings may be left ungrouted for a day. The conditions for tunnelling are obviously good. If we had to tunnel in London with

$$p_z / s_u$$

of the order of 6, I would expect ground movements of at least 10 times the present values. Such movements could not be tolerated in urban London.

In co-operation with London Transport, their consultants Mott, Hay & Anderson, and their contractors A. Waddington & Son Ltd., we have recently completed a series of observations on the motion of the London Clay close around a running tunnel of the Victoria Line during its construction at Brixton. The tunnel is 80 feet deep and it was driven with a hand shield 13.5 feet in diameter and 8.5 feet long with a front hood extending a further 1.7 feet. The shield had a 'bead' about  $\frac{1}{2}$  inch thick and 9 inches long behind the cutting edge which extended around the upper 300 degrees of its periphery. The shield was advanced in steps of about 20 inches, and a ring of permanent cast-iron lining of more or less traditional design was built inside the tail of the shield. A gap about 1.5 inches wide between the clay and the lining was filled with cement grout soon after the shield advanced. The excavation was made full face and it advanced in steps about 20 inches ahead of the shield. When the upper half of the face had been excavated it was open-timbered and held temporarily with a few face jacks while the lower half of the face was excavated. The excavation

was then trimmed to its final shape by the cutting edge of the shield as it advanced again. A few undrained compression tests on small borehole samples show that the shear strength of the clay is about 7000 lb/ft<sup>2</sup> at the level of the tunnel.

Two sets of observations of the convergence of the London Clay towards the tunnel were made by means of sleeved rods anchored at one end in the clay and which extended to nearby underground structures where reference points were established.

First, a set of lateral convergence measurements were made at the axis level of the approaching tunnel at points a, b and c which were respectively 1.6, 6.5 and 11.5 feet outside the tunnel excavation, see small plan in Fig. 1. These measurements were made with reference to an existing parallel tunnel at the same level and 25 feet clear of the tunnel under construction. The total increase in the horizontal diameter of the existing tunnel was 0.024 inch during the construction of the new tunnel, but we know that the remote side of this tunnel did not move horizontally from measurements made with another sleeved rod extending 20 feet into the clay beyond the remote side, see Fig. 1. The convergence measurements are accurate to a few 0.001 inch.

Second, a set of axial convergence measurements were made at three points A, B and C at axis level in front of the face of the same tunnel at a location some 160 feet ahead of the first set of measurements, and 25 feet before the tunnel entered the timbered end of a tunnel chamber about 30 feet long and 16.5 feet diameter lined with cast-iron segments. The chamber was used as a reference point, the chamber did not elongate towards the approaching face and therefore remained quite stable during the measurements. A small plan of the situation in front of the approaching tunnel is shown in Fig. 2. Point A is on the axis of the tunnel, point B at axis level on the periphery of the excavation and point C at axis level, but 1 foot outside the periphery on the other side. The motion of point C was recorded in a direction at a small angle to the tunnel axis as indicated in Fig. 2.

The complete converging motions of the points a, b and c, and A, B and C are plotted relative to the position of the shield in Figs. 1 and 2 respectively. (In examining these figures it may help the reader to imagine that the shield and the tunnel are stationary and the ground flows past them.) The jerky nature of all the movements is real, the faster movements being associated with shoving of the shield. A number of most interesting deductions can be made about the motion of the clay from these very simply measurements and some will be mentioned here.

The lateral motion of point 'a' passing close alongside the shield is particularly

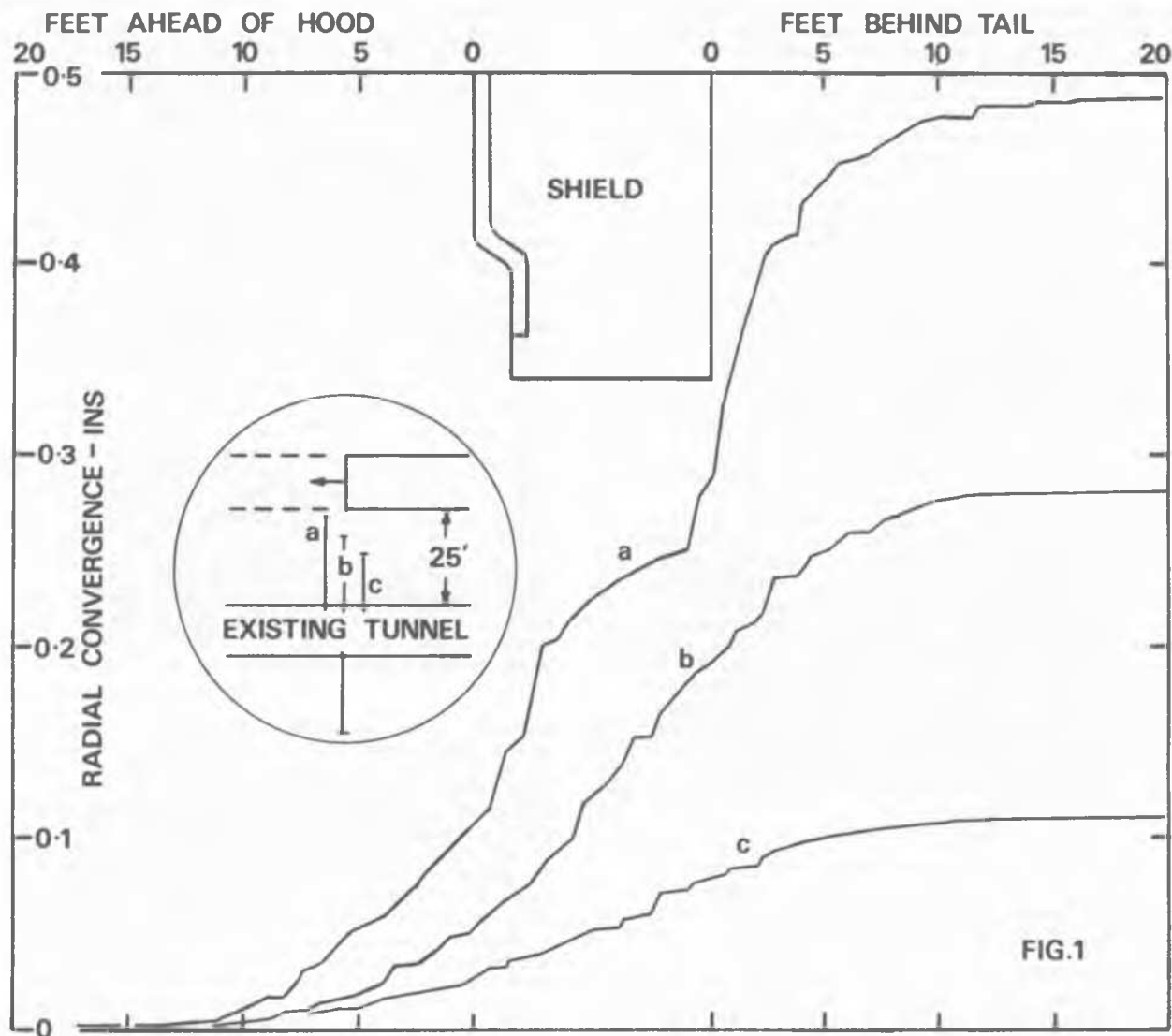

FIG.1

instructive. As the shield approaches, the movement of point 'a' starts abruptly and remains almost linear until it comes behind the head, it then suddenly accelerates and then slows down towards the tail of the shield. This clearly means that the clay after leaving the head converges and bears on to the tail of the shield. As it passes the tail there is the largest sudden movement which subsequently slows down as the grout sets and the lining takes support. The nature of this movement strongly suggests, as I have mentioned already, that the use of the shield only delays the elastic convergence temporarily and does not reduce its magnitude. By extrapolation of the measurements the net radial movement of the clay at the shield boundary is about 0.57 inches, so the total loss of ground for the construction operation per unit length of tunnel is likely to be at least 0.57 times the tunnel circumference, or about 2.4 sq.ft.

Sets of measurements are made frequently by the resident engineers of the settlements of the streets where they cross the line of London tunnels at points directly overhead, and at points half depth away and full depth away on either side. The overhead settlement is typically 0.25 to 0.5 inch and zero at full depth away when a single tunnel passes at about 70-80 feet depth.

This corresponds to a loss of ground of around 3.0 sq.ft per unit length of tunnel. Sets of observations were taken in two streets near to the above underground measurements, but the results vary considerably, the losses of ground being about 1.4 and 5.1 sq.ft. These surface observations are, of course, liable to errors if the natural reference points in the streets are disturbed and this may have been the case here. However the loss of ground of 2.4 sq.ft. estimated from the underground ob-

servations is of the same order as the values estimated from the surface observations. These small surface displacements are not normally noticed in buildings.

Turning now to the axial convergence measurements the very small axial displacement

of only about 0.05 inch close to the edge of the face compared with the displacement of 0.68 inch at the axis, see Fig. 2, reveals a strong dome-like shearing of the face. It is this action which causes opening-up of the fissures which can be observed at the face. The result is also of

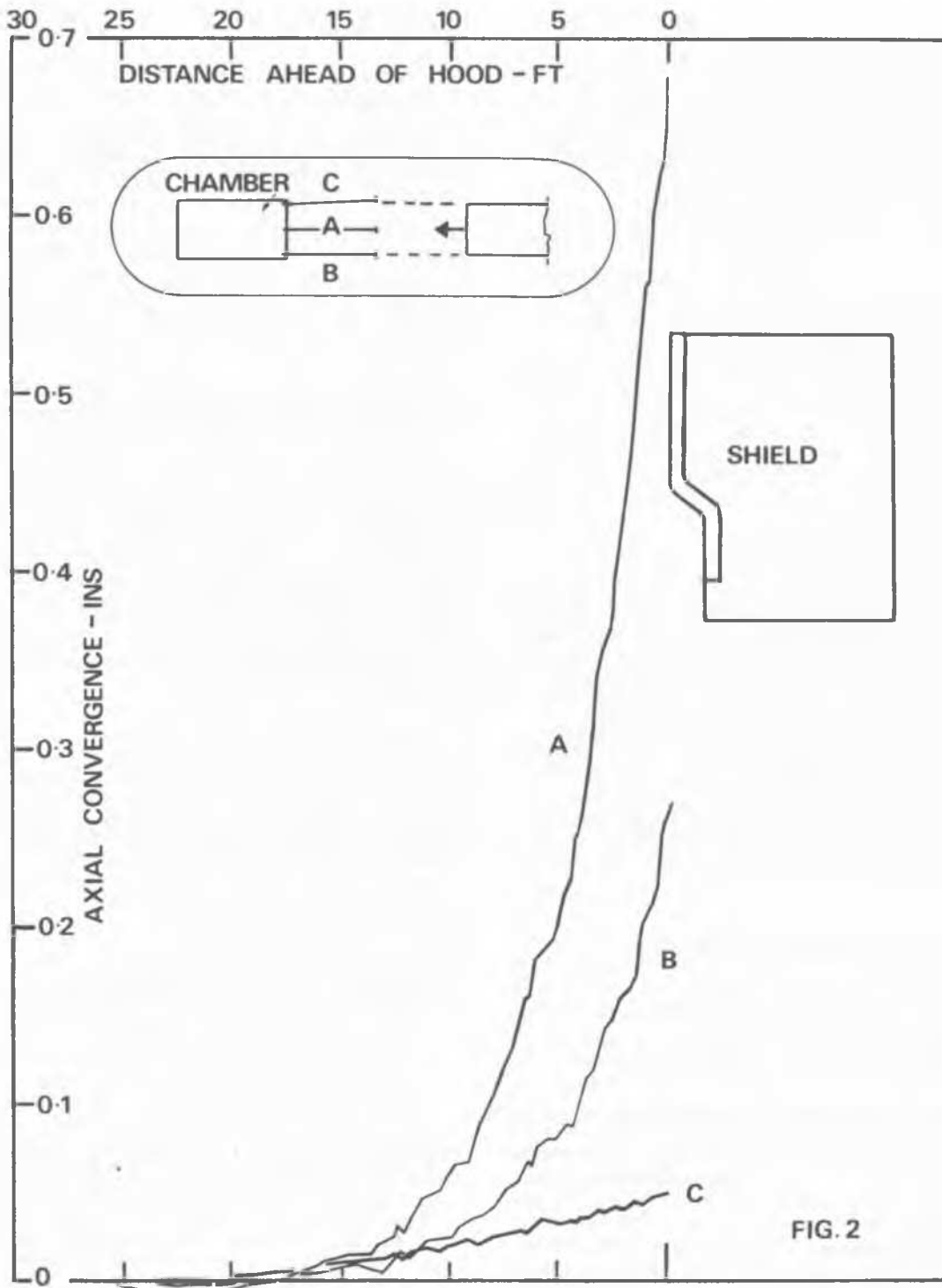

FIG. 2

interest to the problem of disturbance in 'undisturbed' sampling.

in the tunnel with their horizontal joints in line. The three types of lining had the following dimensions and properties.

When part of this tunnel was demolished to make way for a larger one we found with much interest one or more slicken-sided surfaces surrounding the whole tunnel an inch or two behind the layer of grout. The lining segments often came away from the clay on these surfaces, which were all striated in the direction of the tunnel axis. We believe these surfaces are generated by quite small reversible strains arising from the forward shoving of the shield, see curves B and C in Fig. 2, and the backward compression of the lining rings which were spaced with thin timber packing.

The first lining which was used extensively on the Victoria Line had 6 segments and a short key to the ring and was made of grey cast iron. The width of the segment was 20 inches, the skin was 1 inch thick and the ribs 3 inches deep,  $1\frac{1}{2}$  inch thick.

The second lining was quite new; it was made of ductile iron which has structural properties similar to mild steel, it had 12 segments and a short key to the ring. The width of the segment was 24 inches, the skin was  $\frac{1}{2}$  inch thick and the ribs  $2\frac{1}{2}$  inches deep by  $\frac{1}{2}$  inch thick.

#### THE STRUCTURAL BEHAVIOUR OF THREE LININGS OF DIFFERENT FLEXIBILITY IN THE SAME TUNNEL

The third lining was identical to the second except that each circumferential rib was cut through at the centre of each segment into a bolthole, so that the effective depth of the rib was locally only about 0.9 inch. This lining is referred to as 'cut ductile iron'.

In another part of the parallel running tunnels already mentioned at Brixton a full-scale experiment was made to compare the structural performance of 3 types of segmental metal lining of very different stiffnesses. The results demonstrate very well the good sense and superior safety of using more flexible, thinner and more ductile materials for tunnel linings and fully support the earlier thoughts of Terzaghi, which Peck has reiterated in his report. The results of the experiment are of wide interest to tunnel builders.

Some of the structural properties of the metals and of the segments in circumference bending are given below.

At the site of this experiment the running tunnels (13 ft 3 in. O.D.) were parallel to each other, at the same level and only about 2 feet apart. Sections of three different linings were built into the tunnel constructed first. Detailed observations were made of the circumferential strains in each segment in one ring of each type of lining and of the ring diameters before, during and after the construction of the second tunnel. The site was chosen with the two tunnels exceptionally close together, so as to provide an unusually severe distortion of the linings. All the segments were curved rectangular pans with ribs for bolting together at the edges and all lining rings were assembled

The much better structural qualities of the ductile iron will be noted. For about half the weight of metal the moment of resistance of even the cut ductile iron is greater than the grey iron segment. Indeed, even when the ductile iron flanges are completely broken in bending and the segment is well bent it still has a resistance moment of about 60 ton in. It will also be seen that the flexural rigidity of the cut ductile segment is only about  $\frac{1}{5}$  that of the grey iron one.

The net changes in the horizontal and vertical diameters of each of the three linings as the adjacent tunnel was constructed alongside are given below. These distortions are much larger than the normal long-term deformations the tunnel would undergo if it had been built as a single tunnel.

#### Structural properties of the metal

		<u>Grey Iron</u>	<u>Ductile Iron</u>
Tensile strength	ton/in <sup>2</sup>	12	35
Elongation	%	0.5	8 to 15
Young's Modulus	x 10 <sup>6</sup> lb/in <sup>2</sup>	12 to 14	24
Charpy impact	ft lb	1	14

#### Structural properties of the segments in bending

	<u>Weight/10 ft tunnel (tons)</u>	<u>Flexural rigidity (x 10<sup>5</sup> ton.in<sup>2</sup>)</u>	<u>Moment of resistance (ton in.)</u>
Grey Iron	9.8	1.4	65
Ductile Iron	5.3	1.2	140
Cut Ductile Iron	5.3	0.3	75

Change in diameter

	<u>Horizontal ins.</u>	<u>Vertical ins.</u>
Grey iron	0.33	-0.25
Ductile iron	0.44	-0.30
Duc ductile iron	0.47	-0.31

(-ive is decrease in diameter)

It will be noticed that:

1. the increase in horizontal diameter is greater than the decrease in vertical diameter in each case; this is associated with a local outward bulge of the lining at axis level on the side towards the adjacent tunnel;
2. there is little difference in the diameter changes of the two ductile linings despite a four-fold difference in the flexural rigidity of their segments;
3. the diameter changes of both ductile linings are significantly greater than for the grey iron, this is due almost entirely to the ductile linings having twice the number of joints in the ring.

All of these deformations are, of course, perfectly acceptable for the uses to which the tunnels are normally put.

In the segments themselves the smallest circumferential bending moments occurred in the cut ductile iron and the largest in the grey iron. However, the factors of safety against bending failure are in the reverse order; in the grey iron about 2.5, for the ductile about 7.5, and for the cut ductile iron about 7.3. Obviously the ductile iron is still too strong and economies can be made, since it is most unusual to drive tunnels so close in permanent tunnels.

The distortion in the shape of any circular tunnel lining in London Clay in a particular set of constructional circumstances is determined primarily by the properties of the ground. Any stiffness of the lining tends to restrict this distortion. It is clear from the results of the changes in diameters of the three types of lining at Brixton that doubling the number of ring joints has had a far greater effect on the distortion than reducing the stiffness of the segment many times. Yet when both the number of joints is doubled and the segment's stiffness is reduced many times as with the cut ductile iron the distortion is still perfectly acceptable, and at the same time there is more than an adequate factor of safety against bending failure. It is quite evident indeed that the ultimate development of a light, though flexible lining, in which the distortions are controlled almost entirely by the properties of the London Clay has nearly been reached in the cut ductile lining.

Acknowledgement

I am indebted to Mr. T. O'Donnell and Mr. R. Carter of Mott, Hay & Anderson for the information on surface settlements and also to my colleagues Mr. H.S.H. Thomas, Mr. P. Tedd and Mr. D. Burford for their help in carrying out the work at Brixton. The note is published by permission of the Director of Building Research.

Chairman O. MORETTO

Thank you very much Dr. Ward for your interesting contribution and in special to bring some controversial points with respect to the lecture of the General Reporter. I am sure that this controversy will be the base of an interesting discussion when the exposition of all the members in this first part will be over.

By indication of the General Reporter and with the agreement of all the members of the panel, we are going to break in this session the tradition and the chairman of it, is going to expose some experiences realized in his country.

I would like to make a few remarks about tunnel construction in the city of Buenos Aires, where the first subway line was built between 1910 and 1912 using then mainly the cut and cover method.

Buenos Aires city is built up along the shore of the Río de La Plata river on a plain underlain by deep deposits of wind-blown materials that were modified by erosion and redeposition as sedimentation proceeded and at the same time were preconsolidated by capillary action due to drying. This formation, that extends for many kilometers in land, is locally altered by the valleys cut by the tributaries of the above mentioned river that near their mouths have left substantial deposits of soft to very soft clay and loose very fine sand, reaching the soft deposits, in some locations, a depth of up to 40 m. Consequently, in general terms, the service tunnels for the town have to be cut in either one of the following materials:

- 1) A highly preconsolidated loess like formation with properties approaching those classified by the General Reporter as cohesive granular soils
- 2) A soft to very soft clay and or loose very fine slightly cohesive sand.

Tunnel digging in the first type of formation yields a behaviour familiar to such class of materials. Although the soil appears to fit very well to the use of tunnel moles, up to date only classical mining in drifts by either the so-called german or austrian methods have been employed, breaking the soil in chunks with the use of light air hammers, as is shown in fig. 1. Lowering of the water table poses no special problem as the average permeability of



SEANCE PLENIERE 4

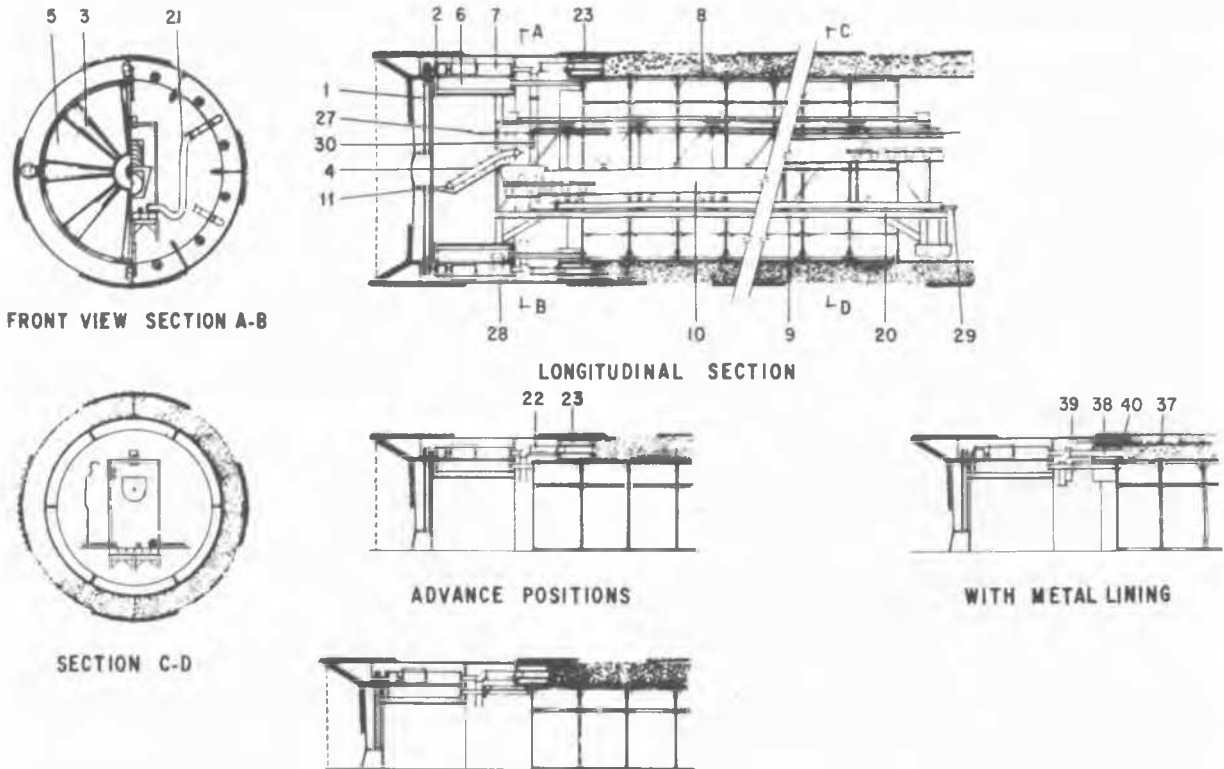

Fig. 2 - Digger shield with continuous mucking and concrete pouring

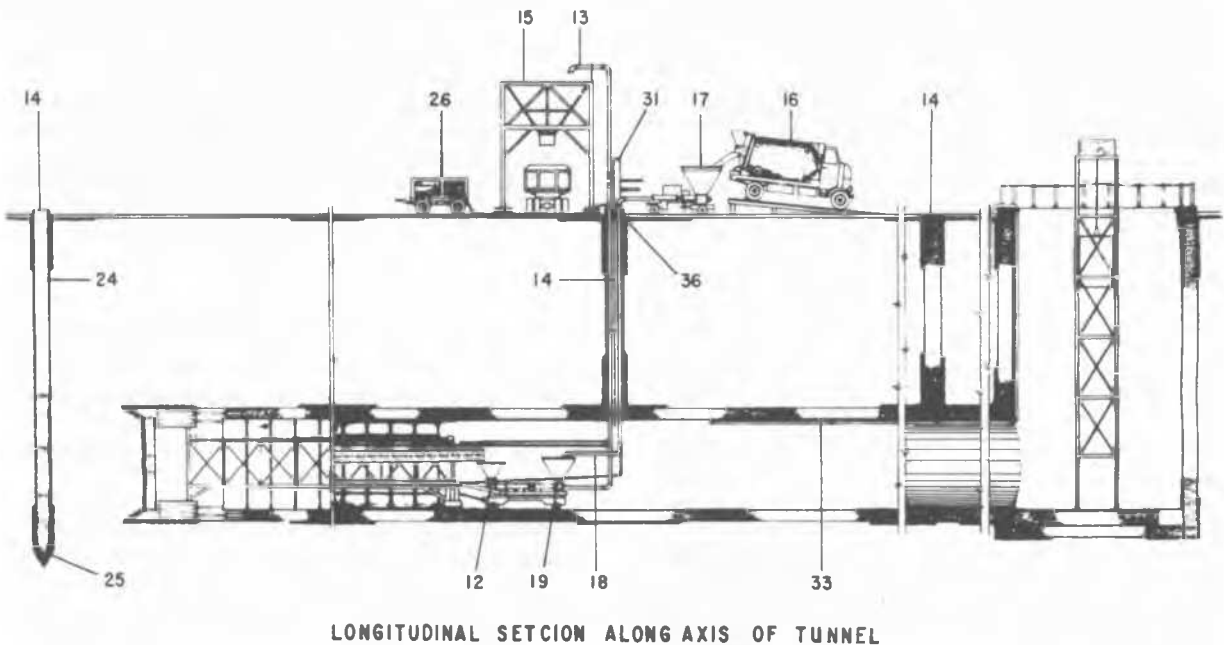

Fig. 3 - Operating method for digger shield with continuous mucking and concrete pouring.

MAIN SESSION 4

the water carrying strata is of the order of  $K = 10^{-4}$  cm/seg and it may be accomplished using longitudinal foot drains located in the invert, inside the tunnels and leading to sumps set 100 to 200 m apart. Barring accidents due to local discontinuities, tunnel excavation does not produce any noticeable effects on the surface and, therefore, no records are kept for settlements.



Several tunnels have been dug through the soft clay and fine sand in the Riachuelo river valley and under the river bed for water supply or sewer. Presently, a water supply tunnel is under construction. The section to be dug in soft ground starts at the northern border of the Riachuelo valley where the soil profile is made up as shown on the left upper part of fig. 5. In the first part, the lower quarter of the tunnel section runs on stiff soil resting on a sand strata. Further ahead, the

stiff cohesive soil disappears and the whole section is dug in soft soil.

A digger shield under atmospheric pressure is being used to advance the tunnel. As first planned, the shield had a long tail that before clearing acted as the external face of a lengthy, travelling concrete mold so that digging and concrete pouring could be accomplished in a continuous operation, as indicated fig. 2. Mucking was achieved by mixing the excavated soil with water, to carry it away with a screw conveyor feeding a pump that elevated the material to the surface. Fig.3 outlines the method of operation. Due to its extensive length and to difficulties arising from the mixed soil profile in which the tunnel was being dug, the machine proved to be unmanageable with a tendency to dip resulting from the presence of stiff soil in the invert zone that could not be corrected. After nearly two years of unsuccessful trials with prolonged stops, the machine was thoroughly modified and transformed into a conventional digger shield. By this time, due to dipping, the tunnel invert had descended 4 m to the level shown in fig. 5, in about half the length set in the project. A temporary support made of steel ribs and plank lining is now being used. It is strongly expanded against the soil, as indicated in fig. 4

The tunnel axis coincides with the vertical line running along the middle of a city street with one to two stories buildings on both sides. Therefore, measurements of settlements are usually limited to the distance between property lines though close observation is kept for building cracking. The right upper part of Fig. 5 shows a typical settlement distribution for the section of tunnel where a temporary support expanded against the soil is being used. It takes the form of an error curve as indicated in the State of the Art Report, measurable settlements extending on each side to a distance of about 25 m from the axis of the tunnel. The

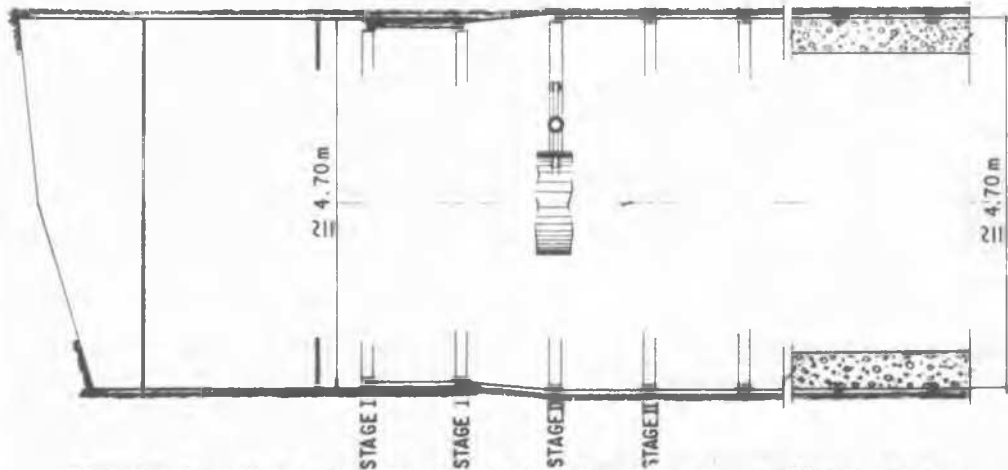

Fig. 4 - Tunneling stages for digger shield used in a conventional manner.

distance  $i = 4.50$  m, gives a ratio  $i/R = 1.9$  and a volume of the trough, calculated with the expression  $V = 2.5 i \delta_{\max.}$ , equal to  $1.7 \text{ m}^3/\text{m}$ , which is equivalent to 10% of the theoretical net excavation. Since  $z/2R = 3.4$ , in fig. 9 of the State of the Art Report, a point is defined barely entering the zone pertaining to stiff-clays.

The lower part of fig. 5 shows how settlement on the axis of the tunnel progresses with time as the shield approaches, passes and leaves the transversal section being observed. It points out clearly that most of the settlement takes place as the shield passes and its tails clear the section being observed, indicating that is mainly due to lost ground and overexcavation. However, to make sure of this evidence, observation points were installed at several levels to find out how their settlement compared with those measured at the surface. The upper right part of Fig. 5 shows the distribution of settlement with depth in the tunnel axis and indicates that near the tunnel crown settlement is slightly larger than at the surface, pointing out that movement of the ground toward the tunnel produces a slight stretching of the soil in its vicinity, a distinct indication that loss of ground is practically the only cause of settlement. When

these settlement observations are plotted in terms of time, as in the lower part of fig. 5, a line is obtained which is identical for every point to that of the surface measurements in the same section.

In spite of all the measures being taken to minimize loss of ground, the surface settlement produced by this tunnel job is several times larger than those reported in the State of the Art Report for tunnels in similar ground. Yet, the ratio  $p_z/s_u$  does not exceed 6.

It may be of interest to state that in the sections where the original tunnel machine worked regularly, the settlements were less than half those reported in fig. 5 while, on the contrary, the conventional shield with an improperly expanded temporary lining yielded twice as much.

I pass the word to the General Reporter in order to conduct the discussion, related to the disagreement released during the lectures of the several members of the panel. Dr. Peck.

General Reporter R. B. PECK

Thank you very much. I have the impression that there are no very great discrepancies in our points of view or in the data. All three panelists have produced some extremely fine data that add a great deal to the State-of-the-Art; precisely the kind of data of which we need much more in order to find out where we really stand in this subject.

I shall address my comments to those of each of the panelists in turn. I do not disagree with Mr. Ward about the proper ratio of net pressure to shear strength. He said rather clearly that he prefers a ratio of 1 or 2 rather than 5 or 6. I certainly do also. I am sure well all would prefer a ratio of 1 or 2, if we could get it. But, if we had to stay within a ratio of 1 or 2, those of us who do not work in such amenable materials as the London clay might not be able to build any tunnels. The point is that with higher ratios there would be more settlement of the streets. In London these settlements might at first glance seem unacceptable. But that is not quite the whole story. The cost of reducing the settlements would be calculable; the settlements could be reduced to some extent at least by the use of a fairly high air pressure. This might for some reasons be a very undesirable thing to do, but it would be a way to reduce the ratio of net pressure to shear strength. The cost of reducing the settlements by this means would have to be balanced against the cost of repairing the utilities or streets, or of underpinning the adjacent buildings, or of doing whatever might be necessary to cope with the damage that might be associated with the movements. So I think another way of saying what Mr. Ward has discussed is that it would be far

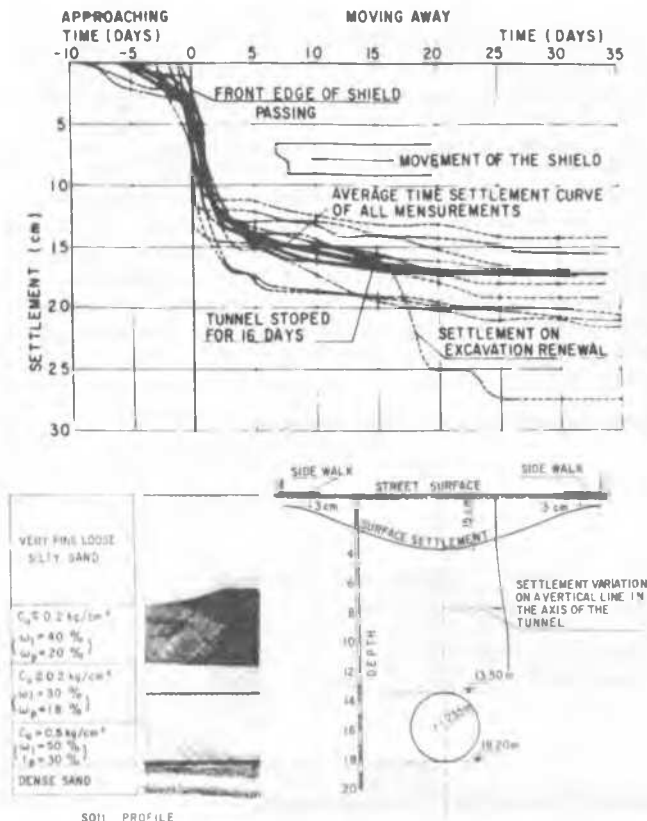

Fig. 5. Soil Profile and Settlement of Tunnel in Soft Soil.

more costly to tunnel if the ratio were of the order of 5 or 6 than it is with the ratio that happily prevails. This does not mean that tunnels could not be or would not be driven in London if the clays there were softer than they are. It means that more money would have to be spent either on the tunneling procedure or on the protective measures.

Panelist W. H. WARD

Well, the point really at issue, I think, is that we tried to reduce this cost, of course, because there are many other cities contemplating underground systems where the ratio is even greater than 5 or 6, and the difficulty is here that people do not want to work in compressed air, it is almost a lethal process these days, and if one is working even at factors of 5 or 6 it seems to me that there is no precise a method of control and this is what we are all looking for and we have not really got it yet. It should be possible to tell, at the shield, more precisely, how much ground you are losing at every small motion of the shield, and this, as far as I can discover, can not be done sufficiently precisely at the moment. It should be possible to go through the ground and control the loss of ground by allowing the soft clay to squeeze in at the same rate as the shield is advanced; you can increase the ambient pressure by thrusting harder against the clay by means of the shield. You do not need to put air pressure into this, at least not theoretically. And I think it should be possible to get much better control over the loss of ground than exists at present.

General Reporter R. B. PECK

I think this is quite correct and it merely highlights that we need to know much more precisely than we do just what are the seats of the loss of ground and just what construction operations could or must be improved in order to make the procedures more feasible, before we change to some totally different procedure. It is not quite so easy as it may seem, however, to hold the clay with the face, and then permit just the right amount of movement into the tail piece to balance the heave that goes with the held face. We tried that a long time ago in Chicago and wound up with a heave to begin with and a settlement afterwards. Even though in a few instances we did come back to about the same place where we started, the massaging effect on the utilities over the tunnel was drastic.

Chairman O. MORETTO

I want to ask the General Reporter to what extent the difference in various types of shields may influence the loss of ground. Contractors in general do not want to use air pressure because the air pressure is too expensive and I have seen in tours here in Mexico City - probably you have too, - that for the soft clays of Mexico City they are

using a shield which is not rotating, it is just pushed. It has a grill in front and it is being pushed against the soft soil. Now, does the general reporter think that if instead of using that type of shield a rotating shield were used, the loss of ground would be larger?

General Reporter R. B. PECK

I can not really answer that question because I believe most of these things would have to be tried out on a full scale to see what really happens. It is very easy to make hypotheses about what this or that improvement or supposed improvement might accomplish, but until we try it, and also perform measurements of the sort that Mr. Ward was describing, until we see what really happens in the ground ahead of the tunnel as well as behind it, we may be wrong in our notions as to what would be an improvement. The only way to settle this is to make appropriate, detailed, field observations.

I think there is assuredly a great room for improvement in shield tunneling by finding some means of eliminating or reducing the effect of the annular space behind the tail piece. This is a source of lost ground that, as far as I can see, nobody has really successfully coped with yet. There are many procedures for doing a better job than has been done in the past, but I would say this particular problem has not been solved. I think that probably more will be gained by looking at this part of the shield operations than at the details of what happens at the face, but this may be another one of those hunches that will be proved wrong by field observation.

Chairman O. MORETTO

Does any one wish to comment on this question?

Panelist W. H. WARD

In one of the soft clay shields I saw in

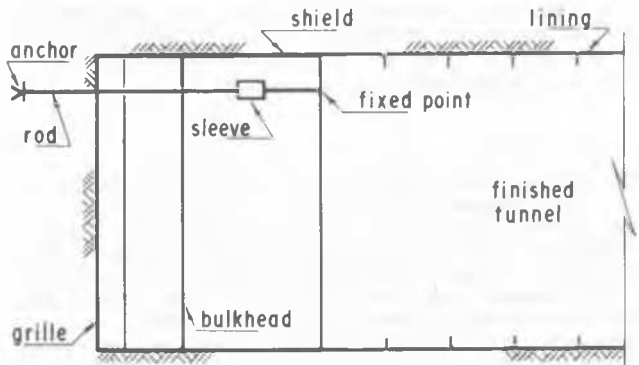

Device for measuring the movement of the soil ahead the shield.

Mexico City, the total release between the nose of the shield and the first lining is  $2\frac{1}{2}$ " so they are losing  $2\frac{1}{2}$ " times the diameter of the shield just from the design of the shield itself; this is apart from what is lost at the face. I would just like to make one suggestion that it is quite technically possible, and that is to measure from the shield how much ground is coming at you by a simple mechanical means:

Chairman O. MORETTO

Is there any other comment?

Panelist T. KUESEL

In all the San Francisco tunnels we had in soft clay at the foot of Market Street, the "N" value in free air, which was something over six, was one of the reasons we specified mandatory compressed air which brought the value down to something below 5. However after we chopped out several hundred piles I am not sure how much contribution the air pressure was making to controlling the loss of ground because there was inevitable loss of ground when we were working in front of the shield on the piles. The problem here is that you can device means of dealing with the prevalent conditions, but you always have to be on the look-out for the exceptional local face conditions which will give you a much greater magnitude of settlement and difficulties.

Chairman O. MORETTO

Does the General Reporter have any comments?

General Reporter R. B. PECK

This is certainly a correct observation. I feel that the air pressure was absolutely necessary on lower Market Street, just to permit making progress and to keep the settlements as low as they were, even though they became quite large over this portion of shield tunnel. It was a deep tunnel in difficult ground; probably we might not have needed as much air pressure if the piles had not been there. The air pressure certainly made the job possible.

I suppose as long as I have the microphone I might comment on Moretto's example. He evaluated the ratio of net pressure to shear strength as 6, which is probably the correct number. I made some rough calculations from the diagram and came out with 10 but the discrepancy really does not much matter. In any event, there was a high ratio of net-pressure to shear-strength and the settlements were quite large. If they differ by a factor of say 2 from those in the diagrams in the State-of-the-Art Report, I think we are in good agreement.

Chairman O. MORETTO

Well, I do not know if I have made a mistake in my calculations but the ratio was 6 and the settlements were really much higher than those that one would expect from the State-of-the-Art. The tunnel was cut in through the lower third on hard soil and the two upper thirds on very soft soil. I do not know whether the non-uniform profile had any thing to do with this exceptional settlement but I am sure, absolutely, that every effort was made to decrease that settlement, with the collaboration of people who have had very great experience with tunnels, including American people who have worked in many soft ground tunnels in the United States. There is only one solution which would probably have worked: the use of air pressure. But, not knowing whether he would get any improvement in the real settlement, the contractor finally decided to live with the settlement and fix the buildings as long as they continued to crack. Fortunately nobody came up with any legal suits so the work is going on that way.

General Reporter R. B. PECK

The legal profession is obviously not very aggressive in Buenos Aires.

Chairman O. MORETTO

Well, with this we close the first part of our session and we will have a 10 minutes recession.

SECOND PART

DEUXIEME PARTIE

Chairman O. MORETTO

The second part of this session will be devoted to deep excavations and will follow the same procedure utilized in the first part so in spite of time I give the word to Dr. Ralph B. Peck who will read his report in the same way as in the first part, for the case of deep excavations Dr. Peck.

General Reporter R. B. PECK

Prof. R. B. Peck's State-of-the-Art report appears on pp. 225 of the State-of-the-Art volume.

Chairman O. MORETTO

Thank you very much Dr. Peck for an interest-

ing summary of the second part of your General Report related to the State-of-the-Art in deep excavation.

The next speaker will be professor Jennings, chief of the Civil Engineering Department, of the Witwatersrand University.

Panelist J. E. JENNINGS (South Africa)

The city of Johannesburg in South Africa, as with many other cities in the world, is passing through a stage of redevelopment with the replacement of existing building by high rise structures. Many of these have deep basements, some of which may extend as much as 90 ft. below the surrounding street levels. The relevant details of the supporting systems for four such excavations are given in Fig. 1 (a) - (d) .

EXPLORATION OF THE SITE

The success of any deep excavation depends upon the care which is exercised in the exploration and in the planning of the work right up to the stage where building below ground level is completed. Once the plan has been decided, the only changes which should be accepted are those which are necessary for the safety of the work. Changes in depth or alterations in the planning of the building which will fill the excavation should not be made. Once started, the whole work should proceed rapidly with a minimum of delay until the final construction is completed.

The preliminary work is as follows:

- (a) A thorough site exploration should be carried out. This must define all strata to a depth which substantially

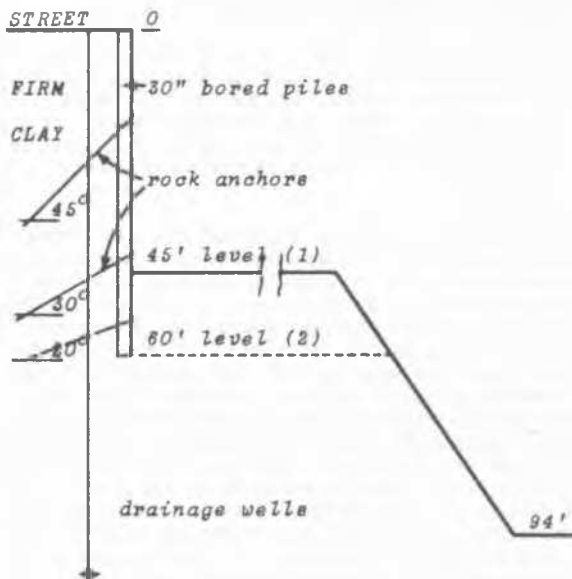

Case (a) 30 in. bored concrete piles held by cables anchored in rock

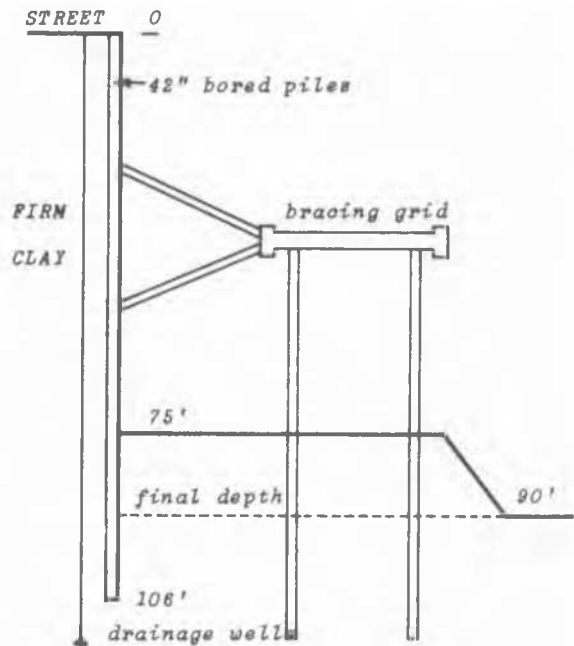

Case (b) 30 in. bored piles braced back to a horizontal bracing system

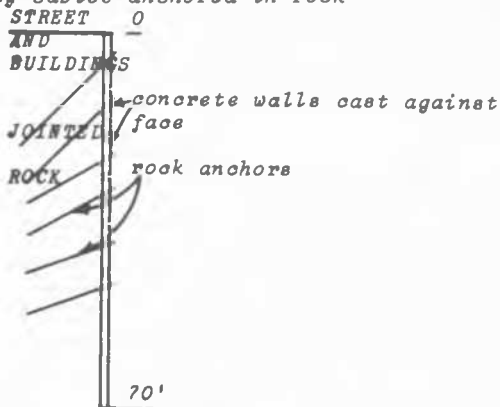

Case (c) Wall slabs cast against excavation and held by cables anchored in rock

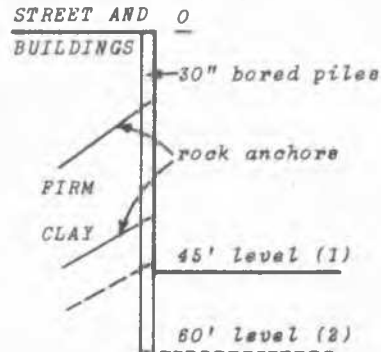

Case (d) 30 in. bored concrete piles held by cables

Fig. 1 Typical cross-sections on Four Basement Excavations in Johannesburg, South Africa

SEANCE PLENIERE 4

exceeds the depth of excavation. All horizontal changes in subsoil should be located. Local variations should also be thoroughly understood, remembering that the greatest difficulties will be experienced in situations where the soil is weakest. All soil profiles should be systematically recorded, noting apparent moisture condition, colour, consistency, soil structure, soil type and probable origin of each stratum. Up to this stage only minimal laboratory tests are required, perhaps only the Atterberg Limits and gradings.

- (b) During the site exploration the water situation in the soil should be clearly defined. Piezometers should be installed in those exploration boreholes where it is judged there is sufficient flow to permit their operation; otherwise 'null-flow' electrical pore-pressure gauges should be used. It is very useful to have several such measuring devices installed at different levels in a single borehole - this will give a measure of any vertical flow gradients in the soil.

When the information in (a) and (b) above has been assembled the engineer should consider the whole problem and attempt to find possible solutions which will give the best marriage between the requirements of both the structure and the soil. He will now be in a position to decide what laboratory or field tests, if any, are required to allow his designs to proceed. He will also be able to decide from which regions the test samples should be taken. He should avoid 'over-testing' as it is confusing and even misleading to have too many laboratory tests on the wrong samples.

**THE DESIGN OF THE SUPPORTING SYSTEM FOR THE EXCAVATION**

Two basic problems must be considered, namely, the overall stability of the excavation and the earth pressures which must be resisted by the system for lateral support.

*Overall Stability* - The most common procedure is to conduct a slope stability analysis using circular surfaces with  $\phi=0$  for soils possessing plasticity, or plane failure wedges with  $c=0$  for non-plastic, freely

draining soils. The effects of water pressures on the surfaces of failure must be included. A depth of tension cracking which should not exceed half the height of excavation should be taken into account in these calculations. The  $\phi=0$  method may give queer results as the excavation approaches a limiting depth.

The procedure suggested by Peck, treating the excavated face as terrace loading has much merit and agrees almost exactly with experience in Johannesburg, i.e. if  $s_u$  is the undrained shear strength of the material below the cut depth and if  $N$  is the stability number,  $N=YH/s_u$ , then:

- (a) no significant deformations will occur if  $N < 3.14$  (based on elastic stresses in the foundation below a terrace loading with a vertical face);
- (b) movements will occur and these will become progressively greater as  $N$  increases from 3.14 to 6.0;
- (c) large movements will occur if  $N > 6.0$  and there will also be a possibility of failure. A value of  $N=6.0$  should be taken as defining the maximum depth of excavation in a particular soil (based on bearing capacity theory with  $\phi=0$ ).

*Earth Pressures on the Support System* - Most support systems undergo a movement into the excavation which is either parallel to the vertical face or a rotation about the top. Hence the earth pressures will be approximately parabolically or trapezoidally distributed, i.e. an arching active condition will be developed. It is accepted that the movements necessary to develop such active (total) pressures are much smaller than those necessary to cause a triangular distribution of pressure. Therefore support systems which rely on developing active pressures by rotation about the toe must receive very special attention because of the larger movements necessary in such cases.

Experience in Johannesburg suggests that the movements of a city basement excavation should be limited to  $1\frac{1}{2}$  in., otherwise damage to street services or buildings across the street may be excessive. The following is a summary of the observations leading to this conclusion:

Predominant Soil Supported	Height of Excavation	Horizontal Movement of Top of Excavation, $\Delta$	Ratio $\Delta/H$	Comment
Firm fissured clay	45'	3"	1:150	Damage to services in the street and buildings across the street
Firm fissured clay	45'	$1\frac{1}{2}$ "	1:360	Acceptable movement
Firm fissured clay	75'	$1\frac{1}{2}$ "	1:600	Acceptable movement
Very stiff fissured clay	45'	$\frac{3}{4}$ "	1:720	Acceptable movement
Soft jointed rock	60'	1"	1:720	Acceptable movement

These data show that as far as damage to street services and buildings across the street is concerned, the tolerable movement is independent of the depth of excavation. When the excavation is carried out adjacent to an existing building the movements may have to be less. Each case should be considered on its particular merits, taking account of the flexibility of the building and the consequences of any damage which may be caused.

However, the ratio movement/depth is known to determine the total support pressure. It is probable that arching active conditions will be achieved when movements exceed a figure of the order of  $H/1000$ . This is fortunate since even with an unusual depth of 100 ft the necessary movement is only  $1\frac{1}{2}$  in. which is within the acceptable range when the surface is occupied by a street. The total horizontal force to be resisted will be the total active pressure and its distribution will be approximately parabolic or trapezoidal. Even if this is an underestimate, the error is unlikely to be greater than 50%. This may be reasonably accepted as within the margin allowed by the factor of safety but before he accepts it, the designer must be quite sure that the water pressures in the backfill will be controlled.

In most support systems it is unlikely that wall friction or adhesion will be developed. A very convenient way of calculating the total pressure is to consider this as resulting from the pressure of a fluid with an equivalent unit weight  $\gamma_E$ . The British Code of Practice No. 2 for earth retaining structures requires that no permanent wall shall be permitted unless it can withstand an equivalent fluid pressure with  $\gamma_E=30$  pcf. Considering Peck's Fig. 33 in terms of equivalent fluid pressure, it is found that for his lower design trapezium,  $\gamma_E=36$  pcf and for the higher trapezium  $\gamma_E=72$  pcf. It is suspected that some of the higher pressures included by Peck may have been due to uncontrolled water pressures, a subject which is dealt with later in this report. Many successful support systems in Johannesburg have been designed using  $\gamma_E=30$  pcf with parabolic distribution of the pressure. There seems good reason to re-examine the position before going to values as high as those suggested by Peck.

In fact it may even be argued that if a  $\gamma_E=30$  pcf is required for permanent constructions then a lower  $\gamma_E$  should suffice for a temporary support. All excavations and their temporary works can be viewed as constructions which will be carried out with competent engineers in attendance. If proper movement records are maintained and if the possibility exists for avoiding action to be taken if the movements threaten to go out of control, then a lower design pressure might be permitted. Certainly successful support systems have been designed and constructed in Johannesburg with  $\gamma_E$  as low as 15 pcf.

## WATER PRESSURES IN THE SUPPORTED SOIL

As in all retained backfills, *water pressure in the supported soil is the major problem.* Excavation below the water table, which is almost an invariable situation with all deep basements, results in transient flow nets which depend upon the rate of excavation, the permeabilities and the rate of replenishment. The effects of water pressures are most severe at the early stages of the excavation. Later, when the equilibrium flow net has been established the required support pressures are smaller. Nevertheless, even at this later stage, the effect is to increase the pressures by about 50%.

The first stage in any deep excavation should therefore be the dewatering programme. In Johannesburg, filter wells at 25 ft centres around the perimeter of the excavation have been found to work satisfactorily. This has been somewhat surprising in the firm clays which are being supported and the reason for the success is probably due to the fact that drainage is taking place along fissures. The wells are 8 in. boreholes with 4 in. slotted casings and with filter sand in the annular spaces. Each well is equipped with a deep well ejector type pump and the water level is controlled at 10-20 ft below final excavation level. Piezometers measure the effectiveness of the drainage and pumping should be started well in advance of excavation.

Other steps must also be taken for the control of water. All street services must be examined to ensure that there are no broken water-carrying pipes. This examination should be repeated at regular intervals throughout the construction. Regular crack patrolling should be carried out around the site and if any crack develops it should be sealed to prevent entry of surface water. Finally, continual watch should be maintained for any abnormal water entry into the excavation - if this occurs, then no effort must be spared in locating and controlling its source. For example, in the excavation shown in Fig. 1(a) a broken water pipe to a lavatory in a building across the street caused the bottoms of a group of piles to move inwards  $2\frac{1}{2}$  in. This caused much alarm until the source was located and the fracture was repaired.

## CONTROL MEASURES DURING CONSTRUCTION

However well the exploration is carried out and the design executed, it must be appreciated that the estimated pressures and other soil conditions are at best only approximations. Throughout the work, as the excavation exposes the soil, careful watch should be kept for conditions which may be different from those which had been accepted in the design. To guide his understanding of the behaviour of the system, the engineer controlling the work should carry out the following measurements:

(a) Precise levels on a large number of



points on the perimeter of the excavation. These levels should have an accuracy better than  $\pm 1.0$  mm. and should be referred to several stable benchmarks remote from the site. These should preferably be placed in boreholes using sleeved rods to a level below the excavation level. It is useful if surface levels on several lines at right angles to the excavation also be observed.

- (b) Horizontal movements of points on the perimeter. These should be observed with an accuracy of better than  $\pm 3$  mm. and should be referred to a sufficient number of 'immovable' points remote from the excavation. The procedures are sophisticated involving both angle and distance measurements with adjustment calculations. A useful procedure is to string a taut piano wire just inside the excavation and to measure displacements of intermediate points from this line. The line itself is surveyed in by attaching markers to the wire.
- (c) Horizontal movements at points on selected levels down the excavation face should be observed from plumb lines, related at their tops to the longitudinal wire in (b) above.
- (d) Rebound markers should be provided in boreholes so that at the completion of excavation a measure of the rebound can be obtained.
- (e) Water levels in differential piezometers around the site should be observed.
- (f) In positions where particular difficulties are expected, flat jacks may be used to measure thrust forces.
- (g) If rock anchors (tiebacks) are used, the tensions should be checked at regular intervals by restressing.
- (h) Regular crack patrolling should be carried out around the perimeter. All cracks should be recorded on a drawing.

In the case of excavations in a city, where claims may be made for damage to adjacent buildings, it is a good idea to have a survey made of the crack situations in such buildings before excavation is started. All existing cracks should be plaqued and photographed. This is a good insurance measure which helps to minimise troubles and delays to the work.

Good control measures are most important for the successful progress of the work. They serve to give the engineer a quantitative record of the behaviour of his system. They also give him early warning of impending trouble, allowing him time to plan and execute any avoiding measures which may prove necessary.

#### EXCAVATIONS IN ROCK AND STIFF FISSURED SOILS

The behaviour of these materials depends upon the behaviour along joints rather than on the strength of the material in between the joints. Many rock faces may be cut vertically to considerable height without any support but others must be supported as if the material were a soil.

The designs of the support systems are based on data provided by joint surveys and estimates of strength along potential failure surfaces which incorporate the joints. The methods of design are dealt with in another paper to this conference. The economic benefits of such designs may be very considerable.

#### THE FACTOR OF SAFETY

In the calculations of overall stability, based on slip circle or plane failure theories, current practice favours a factor of safety applied to the strength of the material, i.e. an allowable developed strength,  $s_d$ , is taken as  $1/F$  of the available strength. The procedure suggested by Peck, treating the excavated section as a terrace loading applies a factor of safety which varies from about 2.0 ( $N=3.14$ ) to 1.0 ( $N=6$ ). This does not seem unreasonable but  $F=1.0$  should never be applied if ordinary slope theory is used. Here  $F$  should not be less than 1.5.

In the design of the supporting structures the earth pressure should be calculated as if plastic failure is already occurring, as is the case for fully active or arching active pressures. The factor of safety is then applied to the structure itself which should be made strong enough to resist at least 1.5 times the anticipated applied loads. By 'supporting structure' is meant all types of support, strutting, piling and rock anchors.

#### EXTRANEOUS FACTORS IN SUPPORTING SYSTEMS

In typical shoring for shallow excavations the designer usually neglects factors such as dimensional changes in the components of the supporting system. However, when the excavations are deep and the supporting systems are complicated, such changes become important as follows:

- (a) Shrinkage and creep effects may cause shortening in materials such as concrete. Long members may experience shortening which is of the same order as the tolerable street movements.
- (b) Temperature effects can cause shortening or lengthening of supporting members. The seasonal changes are the most important and movements of long members can be of the same order as the tolerable movements.

The above effects may compel the engineer to instal flat jacks at his supporting points and to effect changes as the movements occur.

## CONCLUSION

Experience with the digging of several deep excavations in the city of Johannesburg has shown that while the design estimates of overall stability and earth pressures are of great importance, the problems of support do not end with a subsurface investigation and the design of a system. The mental work continues throughout the whole exercise until the whole of the structure below the ground has been completed.

Chairman O. MORETTO

Thank you very much Prof. Jennings for your very interesting contribution.

The next contribution belong to Eng. T. Kuesel whose introduction I already had the opportunity to do in the first section.

Panelist T. KUESEL

Mr. T. Kuesel's contribution appears on page 312 of this volume.

Chairman O. MORETTO

Thank you very much Eng. Kuesel for an interesting contribution related to the construction and behaviour of a special type of sheeting that is becoming very popular and that you have had the opportunity to see in spread way in the Mexico City subway construction.

The next contribution will be in charge of Dr. M. Endo, Director of the Takenaka Technical Research Laboratory of Tokyo.

Panelist M. ENDO (Japan)

## SYNOPSIS

Excavation of ground can be divided into work that can be planned according to normal methods and work which must be studied for feasibility of each individual case with a basic change in the thinking. The greatest difficulties are encountered when performing excavation of ground thickly deposited with a very soft stratum of alluvial clay where there is fear of base failure. Descriptions are given and data presented on a number of examples of such cases, examples of measurements of bottom heave due to deep excavation, and of effects on buildings in the surrounding area of excavation sites.

## FOREWORD

According to the city ordinances, buildings in Japa-

nese cities are required to have internal parking area in proportion to the total floor area. A large-sized building also requires several basement floors for machine rooms to house mechanical equipment, shopping centers on the first or second basement, warehouses, building maintenance and so forth. Consequently, almost all large-sized buildings to be built in the center of cities have three or more basement floors. A considerable number of them have five or six basement floors. As for depth, not a few cases of construction of the basement as deep as G. L. -25 to 30 meters have been carried out. For example, the new building of the head office of the Bank of Japan is G. L. -32 meters deep, and the new Tokyo underground station, G. L. -28 meters deep. On the other hand, as cities develop, buildings equipped with the basement became to be constructed in the area with bad ground conditions where large-sized structures had not ever been built.

Apart from these tendencies cities, the troubles, seen in the constructions of underground structures for facilities of factories on very soft ground which is reclaimed by means of dredging, have been rapidly increasing.

Professor Peck points out in the report of this conference such problems as lateral movement and settlement of the surrounding ground, base failure, and earth pressure. These become very serious problems to be solved when underground construction work above-mentioned is carried out. Particularly base failure is the most difficult problem.

This report will describe the observed examples of deformation as well as the means and methods now adopted in Japan to solve these questions, to supplement the extensive and systematic report of Professor Peck. Now in Japan, the tunnelling method in soft ground has been actively put into practice both in the tunnel shield process and the mechanical tunnel shield process. But this method will be omitted here because it is not long since it was developed and the generalization is not yet established.

## 1. INTRODUCTION

The Japanese archipelago, consisting of four main lands and numerous small islands, is geographically mountainous, so that the lowlands are situated mostly on fans and deltas which form, in all, less than one-fifth of the whole land, and most of the lowlands are covered by alluvial strata. Major cities such as Tokyo, Osaka, Nagoya, etc. are located on the alluvial strata near the seashore for convenience of transportation. Those cities can be divided into two areas, i. e., downtown which is covered by the deep layers of alluvial strata and uptown covered by diluvial deposit. Fig. 1 shows the depth of alluvial strata and their distribution in Tokyo, and Fig. 2 those in Osaka. In both cities, the top layer of alluvial strata is sand or silty sand of some meters and the next layer is very soft or soft silty clay, featuring a constant increase in shearing strength as the depth goes deeper. The distribution of shear strength of these clayey soil of Tokyo and Osaka are shown in Figs. 3 (a) and 4, respectively.

In contrast with the alluvial strata, the diluvial

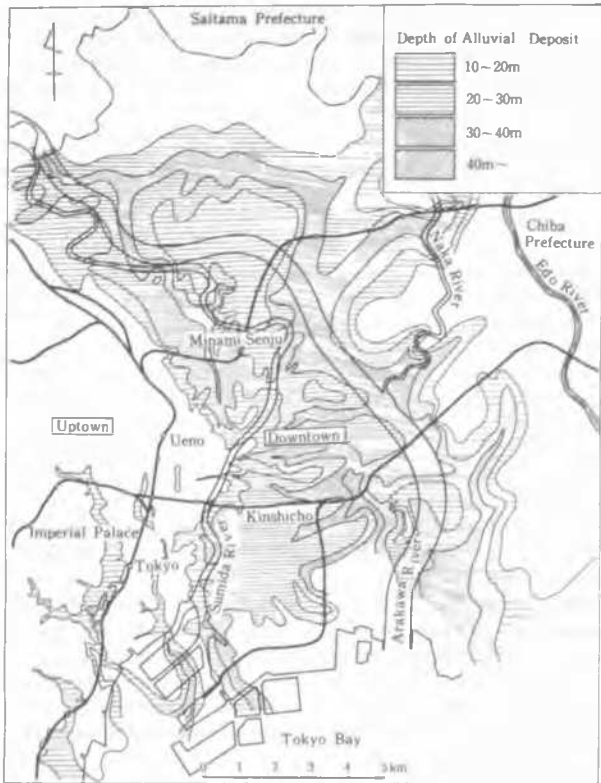

Fig. 1. Depth of Alluvial Deposit in Downtown, Tokyo

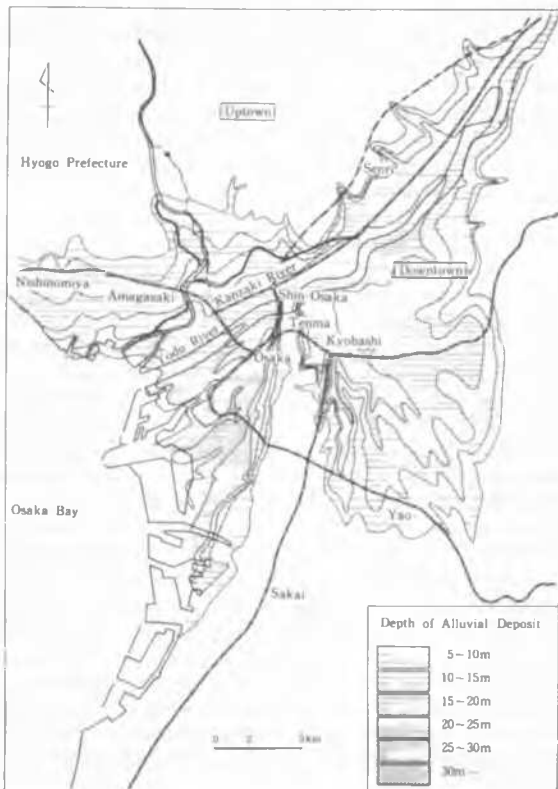

Fig. 2. Depth of Alluvial Deposit in Downtown, Osaka

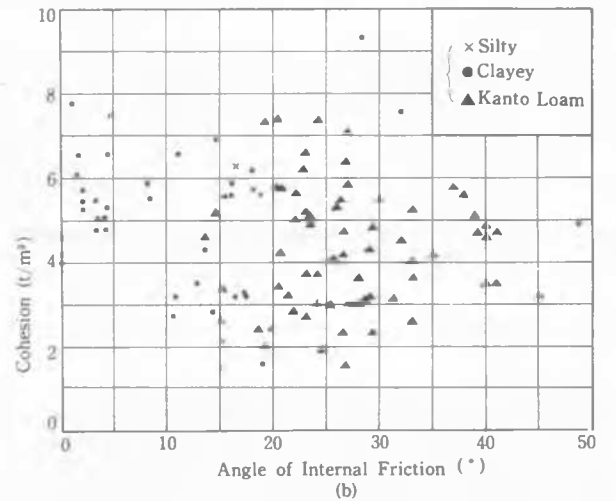
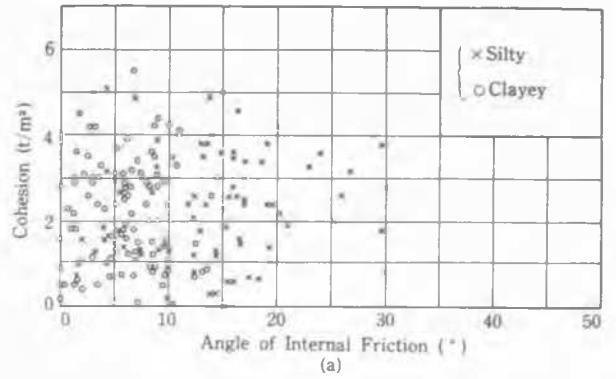

Fig. 3. Relation between Cohesion and Angle of Internal Friction of Silty and Clayey Soils in Tokyo; (a) Alluvial Soils; (b) Deluvial Soils

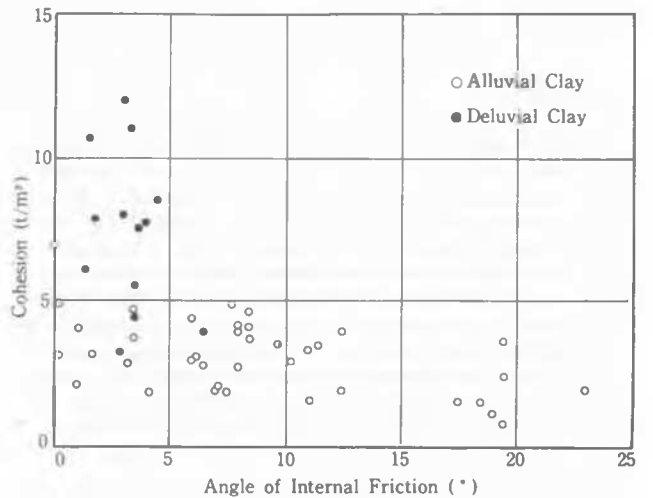

Fig. 4. Relation between Cohesion and Angle of Internal Friction of Clay in Osaka

strata of uptown indicate rather favourable condition for deep excavation although they contain some soft soil, as shown in Figs. 3 (b) and 4.

Consequently, the methods of deep excavation employed for diluvial strata of uptown (Case A) differ from those for alluvial strata of downtown. With regard to the alluvial strata of downtown, the excavating method varies in accordance with the thickness of the strata: less than 10 m (Case B), less than 20 m (Case C), and more than 20 m (Case D). Problems and difficulties often arise in the last two cases, i. e., (C) and (D).

In Cases (A) and (B), an ordinary excavating method is employed with sheet piles or soldier piles and planks supported by struts or rakers. As far as this method is concerned, there is few to add to the detailed discussions given by Professor Peck. One small thing to add is that the record of soil pressure measured in the sand layer is in fair agreement with the soil pressure distribution discoursed by Professor Peck, as shown in Fig. 5.

In Cases (C) and (D), careful preparatory studies for the prevention of base failure, lateral movement

of the surrounding soil, ground subsidence, etc. are made case by case. Undermentioned are some examples of those studies.

Recently, an ordinance for preventing noise was established in the cities, restricting pile driving practice, which produce large noises and vibrations. Therefore, the construction companies are endeavouring to develop noise-and vibration-less methods and began to employ cast-in-place concrete wall method and bored pile method.

Another problem which began to be spotlighted recently is an excavation in artificially reclaimed lands of littoral industrial districts. Those reclaimed lands are made of sand and silt of the sea bottom which were carried up by dredgers. In extreme cases, an 2.0 m excavation caused base failure and breakage of underlaid steel pipe piles. In such a place, it is a very difficult work to dig 4 - 7 m pits for a plant building.

2. EXCAVATION METHODS FOR GROUND OF THICK ALLUVIAL CLAY

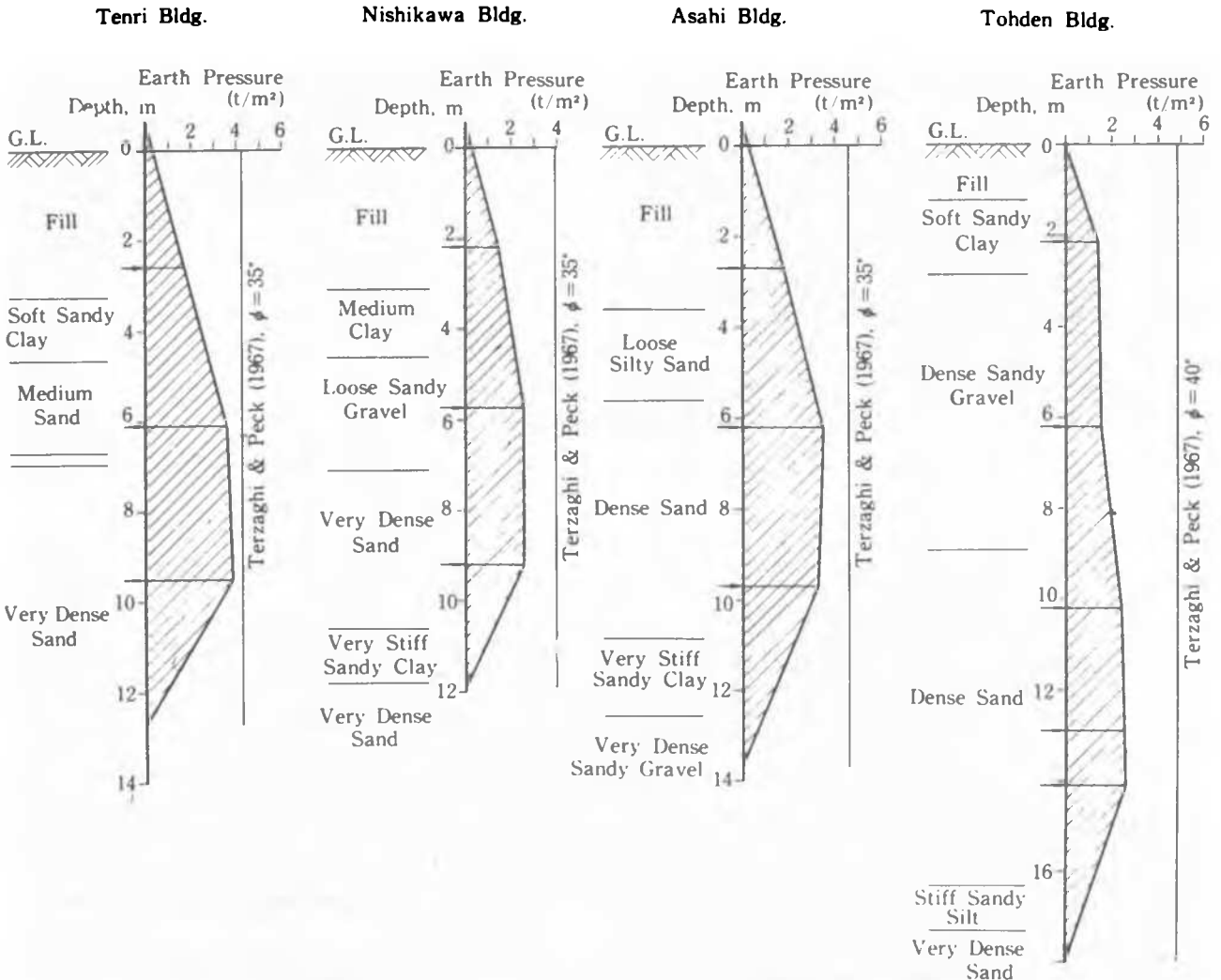

Fig. 5. Observed Maximum Earth Pressure Distribution at Steady State Condition in Sand Strata

In such cases as the beforementioned (C) and (D), when the depth of excavation exceeds 7 or 8 m,  $N$  as pointed out by Professor Peck becomes about 5 or 6, and there arises the danger of increase in deformation and of base failure. This of course is influenced by  $S_u$  of the ground being excavated and by the manner in which the excavated area is expanded. In a subway project at Hibiya, Tokyo, an open-cut work site with two stages of struts provided for lagging wedged against inside flanges of soldier piles, a typical base failure occurred when excavation reached  $H = 8.1$  m, judging by which it is thought that the neighborhood of this value is a limit for alluvial strata in Japan. The value of  $N$  in this case was about 5, and it is thought that the conditions were such that failure would occur two-dimensionally.

When excavating this type of ground to depth greater than above, measures must be taken to minimize adverse effects of changes in stresses formed in the ground by excavation.

#### AN EXAMPLE OF OPEN CAISSON METHOD

As one example, an open caisson construction in the immediate neighborhood of the site of the failure in the subway project will be described.

This open caisson had a weight of 25,000 tons, plan dimensions as indicated in Fig. 6. The cutting edges underneath the perimeter walls and supporting slabs along the perimeter walls were provided to support the weight of the caisson on the soft soil.

Fig. 7 shows the direction and magnitude of principal stresses in the ground determined by the two-

dimensioned elastic theory for the case of uneven height of the ground as indicated by the bold line. Fig. 8 shows the resultant principal stresses also determined by the elastic theory of the stress transmitted to the ground from the surface of the perimeter walls of the caisson, the stress from the weight of the caisson transmitted from the supporting slab and cutting edges, and the stress caused by the weight of soil assuming that the initial coefficient of earth pressure at rest is 1.0. As is seen from the figure, the resultant maximum principal stress is oriented outward immediately below the cutting edges of the caisson, indicating that the weight of the caisson pushes back the intrusion of soil from outside. However, in this case also, the direction of the resultant principal stress is gradually changed from outward to vertical with increasing depth. If there had been no hard ground underlying and the alluvial silt stratum had continued to greater depth, the ground on the outside would have circumvented the perimeter walls to the



Fig. 6. Plan of an Open Caisson

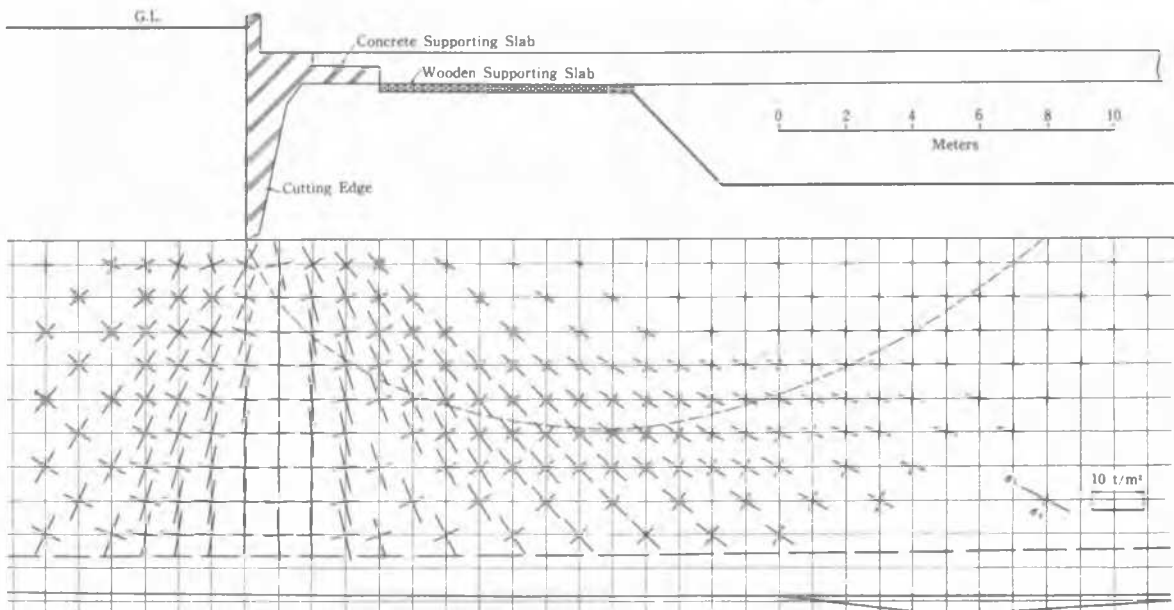

Fig. 7. Principal Stresses in Ground, Calculated by the Two-Dimensional Elastic Theory for the Case of Uneven Height the Ground as Indicated by the Bold Line

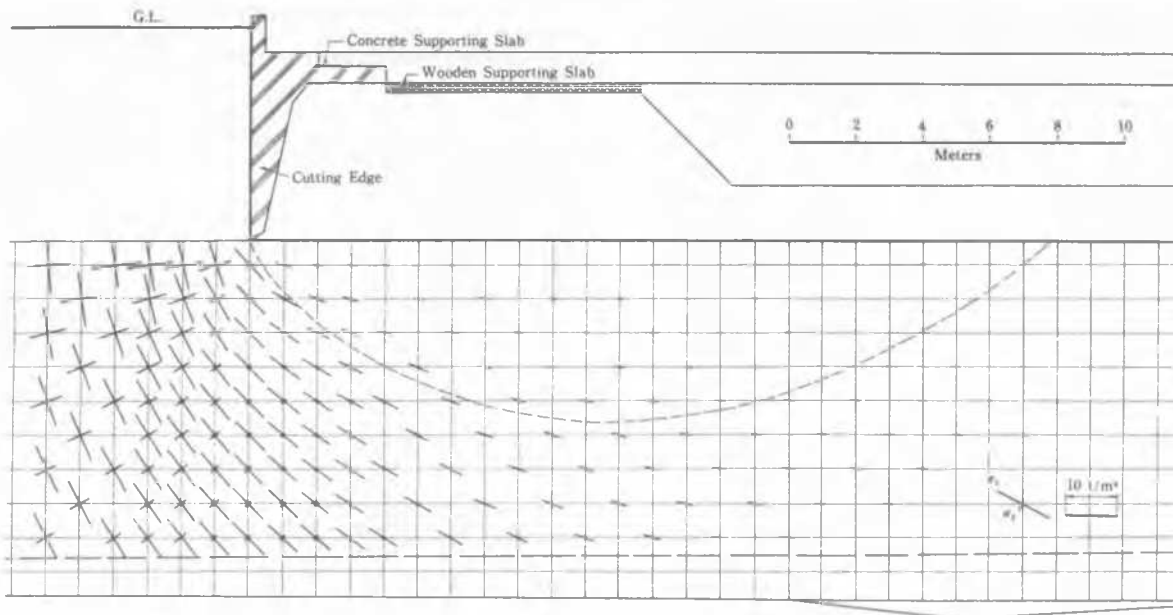

Fig. 8. Resultant Principal Stresses in Ground Prior to First Sinkage Calculated by the Two-Dimensional Elastic Theory

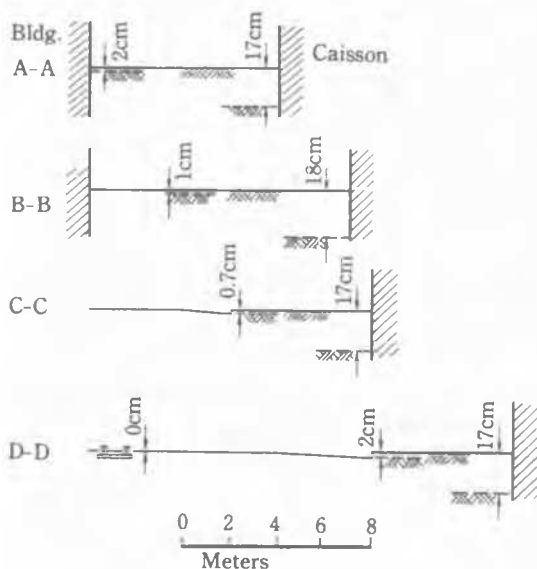
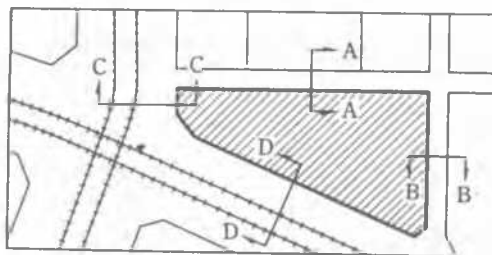

Fig. 9. Observed Settlements of Street Level after Settling of the Caisson

inside and this excavation method would have been inappropriate. This caisson was sunk to G. L. -17.3m and the results of measurements of the street level on the exterior before sinking and after settling of the caisson are shown in Fig 9. In this case, it was attempted to reduce friction by providing an inverted taper between the perimeter walls of the caisson and the surrounding ground filling the gaps with pea gravel, but apparently this measure was inadequate since in Fig. 9 the settlement immediately outside the wall was considerable due to pulling in of the neighborhood soil, although 6 to 8 m away the settlement became extremely small.

AN EXAMPLE OF TRENCH METHOD

In the city of Osaka, a project as shown in Fig. 10 was planned by the island method for a typical (C) - type ground consisting of loose or medium dense sand down to G. L. -4.0 m, loose silty sand from G. L. -4.0 to -8.0 m, and very soft alluvial clayey soil from G. L. 8.0 to -20.0 m as also shown in Fig. 10. At the stage that some progress was made in the project, cave-ins of 40 to 50 cm occurred at the places indicated in the figure as well as movements of sheet piling and slopes towards the interior. Because of this, careful soil tests were performed on the alluvial clayey soil and results as shown in Fig. 11 were obtained. Due to concern for safety of the plan based on the island method, the method of excavation was switched to the trench method. In Fig. 11 are recorded the apparent shear strengths calculated back from a safety factor of 1 based on the beforementioned sliding for base failure and slope failure. Both show values slightly lower than the average curve of shear strength used for design, but the agreement is fairly good.

As a result, since it was judged that the condition was unstable two-dimensionally, the suggestion of Bjerrum and Eide (1956) was adopted and safety factors of 1.45 and 1.28 respectively were obtained against base failure for  $L=B$  and  $L=3B$  when excavating trenches with widths of  $B=14$  m. Although the safety was tentatively assured, in this case  $N=4.5$  was indicated which was larger than 4, so that deformation of the surrounding ground was considered a problem. On the other hand, the constructor wished to adopt as large a figure as possible for  $L$  for reasons of expediting the work, and consequently, a trial excavation was made at the location indicated in Fig. 12, and measurements of movement of the surrounding ground were made. This test was started with  $L=B$ , following which  $L$  was extended in both directions to see the relationship with movement of the surrounding ground, measurements consisting of the settlement at the ground surface and at G.L. -9.0 m, and of widths of cracks appearing in mortar troweled on the ground surface. Measurements were made at 20 points (ground surface only) parallel to the trench and 5 points (ground surface and G.L. -9.0 m) transverse to the trench. For measurement of settlement, a point 5.0 m farther away from the northwestern corner of the construction site considered unaffected by this excavation was selected as the reference point and an optical level was used to secure a precision of 0.5 mm. The progress of the test excavation is given in Fig. 13(b), and the results of settlement measurements were as shown in Fig. 13 and 14. The large settlements at Points E and e were

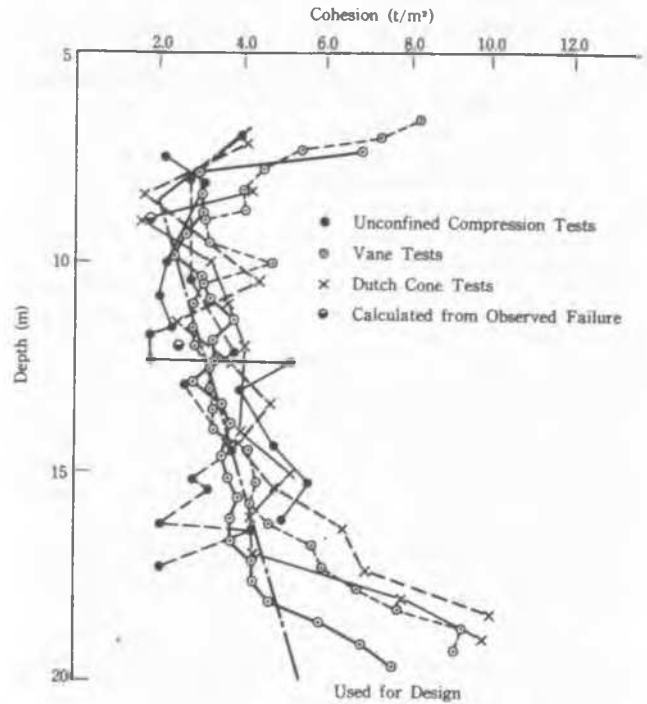

Fig. 11. Comparison of Cohesion between Test Results and Calculated Results from Observed Failure

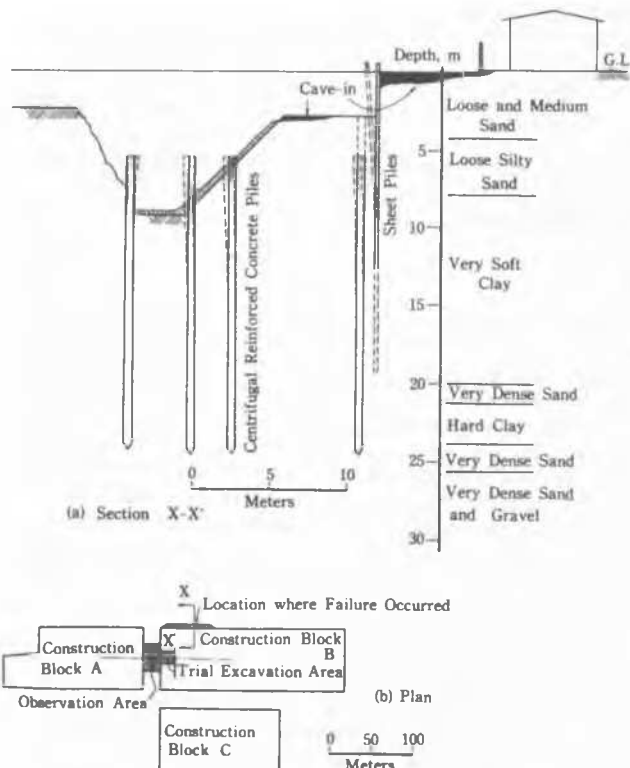

Fig. 10. Osaka S. Bldgs. Project, Showing Cave-ins and Lateral Movement of Sheet Piles and Piles

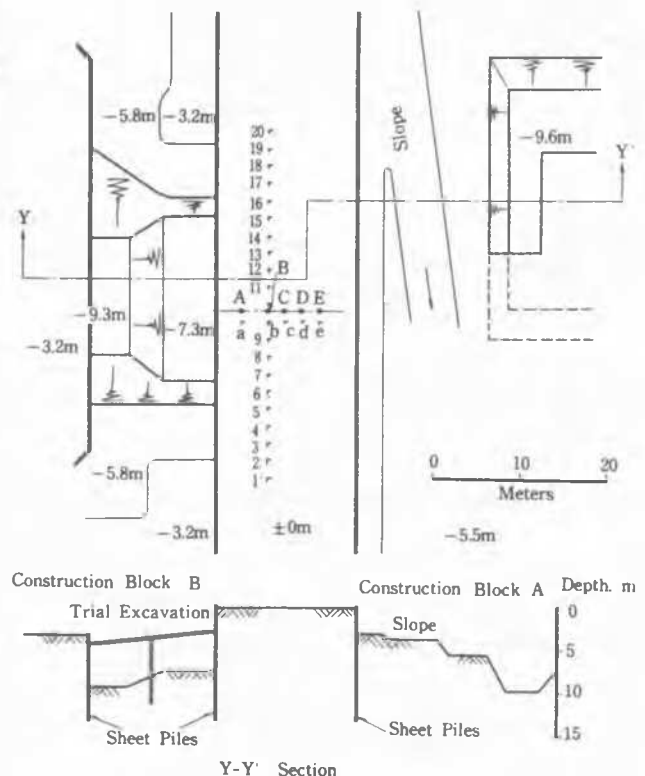

Fig. 12. Trial Excavation to Observe Movement of the Surrounding Ground

due unfortunately to progress of excavation for an adjacent construction project during the measurement period. The horizontal displacement as measured by cracking ultimately resulted in a total cracking width of 83 mm, but the movement towards the adjacent construction site could not be discerned so that the amount of movement in the direction of the trial excavation could not be clearly grasped. In any case, because of the substantial settlement, it was decided to construct a foundation and measurements were discontinued. The relation between the value of N and the value of the amount of settlement at Point A in this example is indicated in Fig. 15, which is in good agreement with the values indicated in Professor Peck's report.

Needless to say, this trench method aims to al-

leviate the distortion of ground stress at deeper portions through excavation in small divisions.

CASE OF FLOATING ISLAND METHOD

The floating island method, as indicated in Fig. 16, consists of providing soldier pile walls or continuous concrete walls around the perimeter of a building, drilling holes at the locations of inner columns using large-diameter drilling equipment, erecting structural steel of the building columns, assembling the structural steel for beams simultaneously with start of excavation at the ground surface, and placing concrete to complete the underground floors of the building from

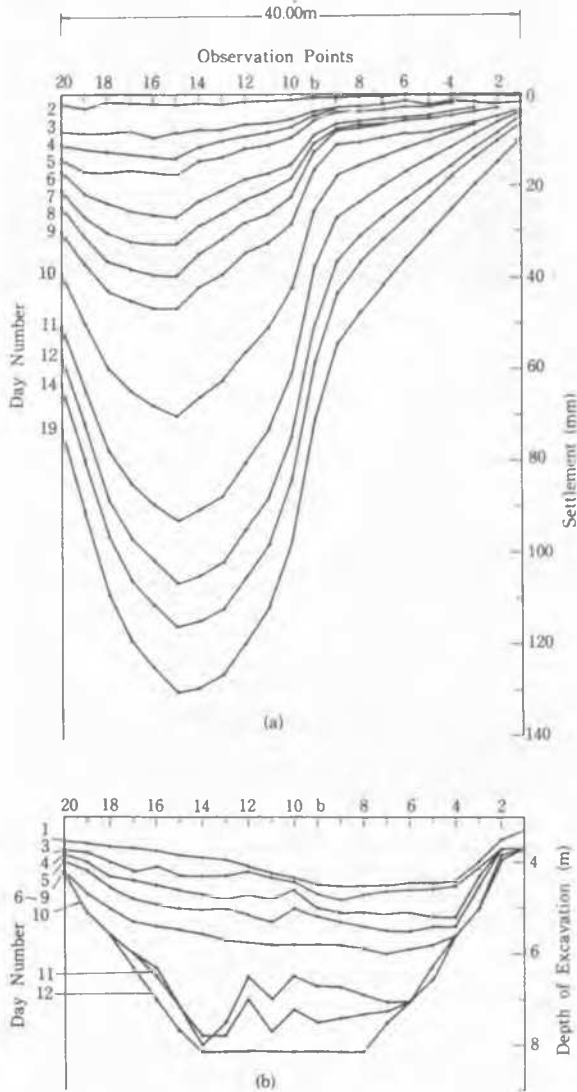

Fig. 13. (a) Observed Settlements at Points 1~20 (G.L. ±0m)  
(b) Profile of Trial Excavation

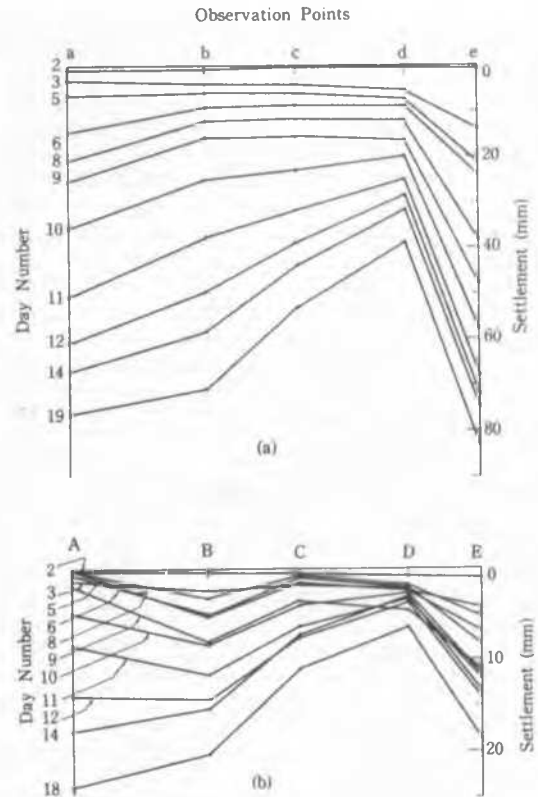

Fig. 14. (a) Observed Settlements at Points a~e (G.L. ±0m)  
(b) Observed Settlements at Points A~E (G.L. -9.0m)

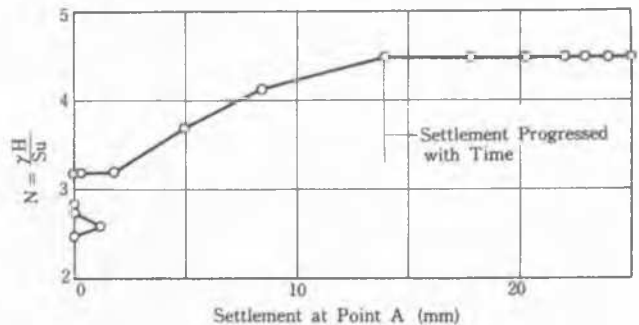

Fig. 15. Relation between N and Observed Settlement at the Point A in Fig. 12.



SEANCE PLENIERE 4

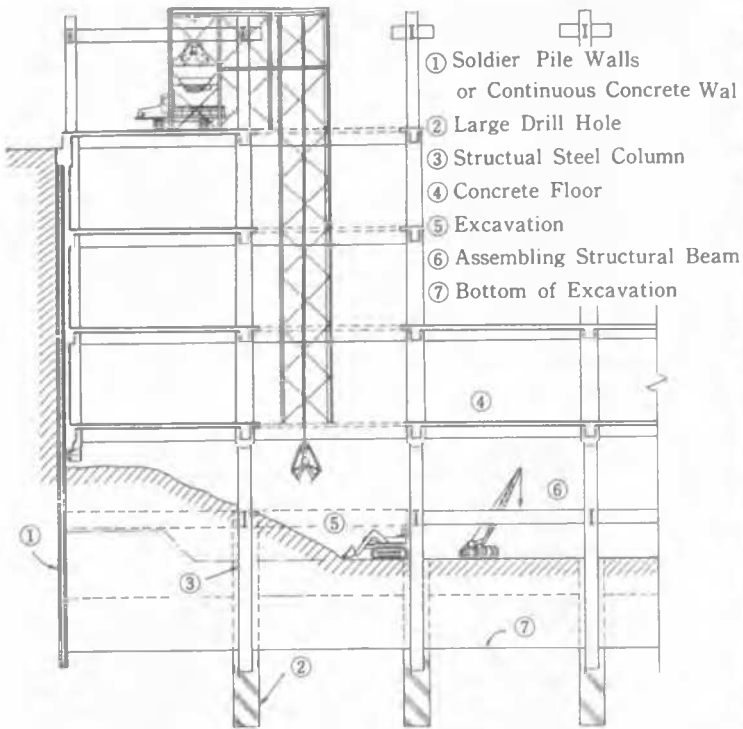

Fig. 16. Floating Island Method



Fig. 18. Inside View of a Floating Island Method

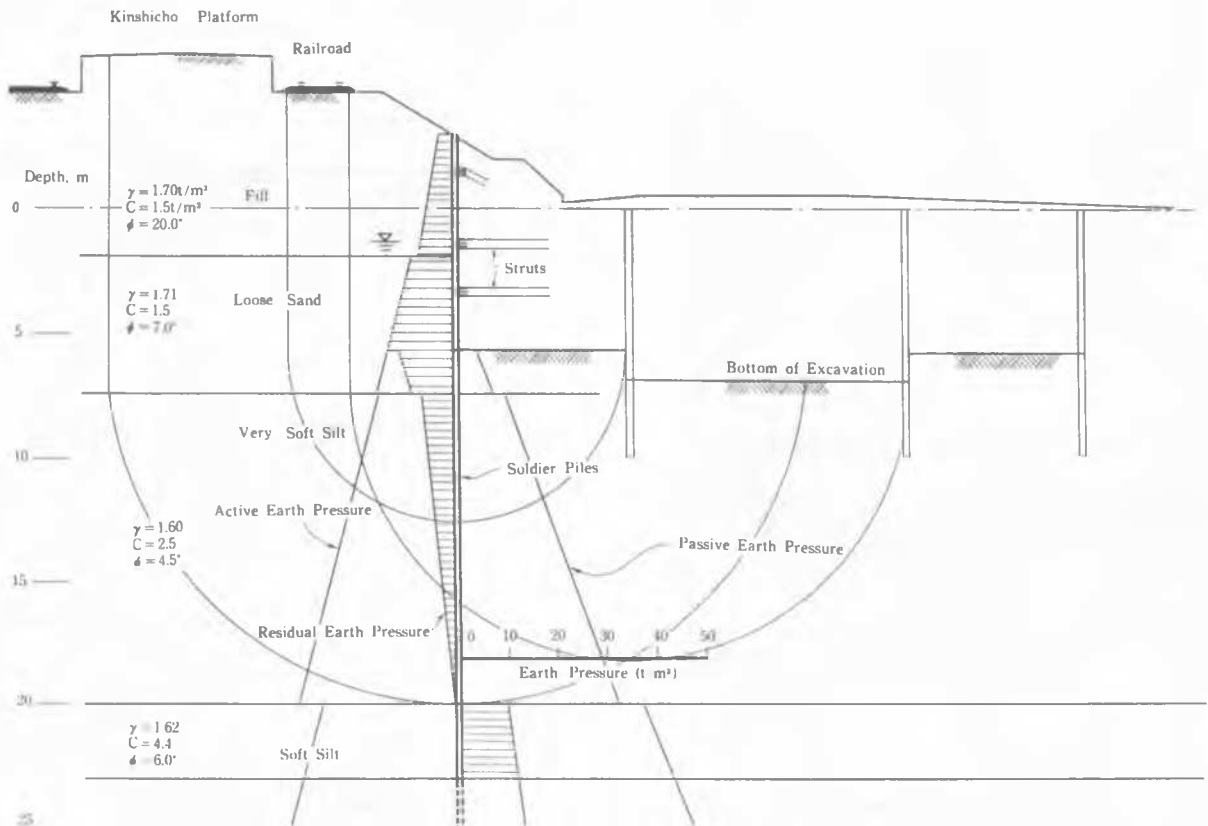

Fig. 17. Cross Section of Kinshicho Station Bldg. Project, Showing Equilibrium of Sheet Piles

the top downwards, presently being the mainstream method in Japan of constructing deep basements. Using this method, construction above ground can be proceeded simultaneously with construction of the underground portion, and there is also the advantage of proceeding with construction while applying the weight of the building to the ground at least underneath the foundation. In this method, the principle of preventing base failure through rigidity of the perimeter sheeting walls to withstand earth pressures is applied. In zones of very soft ground, passive earth pressures in the interior are hardly active and the intersecting points of the sheeting walls are moved deep into the ground so that extremely large bending moments would act on the sheeting walls. In such cases, the sheeting walls would be designed to have adequate reinforcement, but also struts can be provided diagonally downwards from already completed upper floors for further reinforcement.

A case in which base failure was prevented under conditions for its occurrence through the resistance of sheeting walls is described below.

A railroad station building was to be constructed at Kinshicho Station in downtown Tokyo and the toe of an embankment for railroad tracks was to be excavated 7.0 m as shown in Fig. 17. The ground was as indicated in Fig. 17, and when combined with the loads of trains,  $N$  would be about 7 to 8. Excavation would be performed over a length of 120 m and as it was considered to be a case of two-dimensional equilibrium, various countermeasures were studied. It was deemed that the trench method or methods depending on soil stabilization were undesirable from the standpoint of the construction period and so sheeting walls were decided to be used. The active and passive earth pressures acting on the sheet piling were obtained as values of earth pressure in the triangular Rankine distribution, and on seeking the fixed point in the ground the result as shown in Fig. 17 was obtained demanding exceedingly great rigidity and strength of the piles. Since sheet piles with the largest cross-section were still inadequate, a soldier pile wall constructed with concrete piers 980 mm in diameter spaced at 1,060 mm center-to-center and reinforced with 40 steel bars 25 mm in diameter were provided as a countermeasure. In carrying out the actual work, it was found that compressive stresses of 1- to 2-stage struts as measured by earth pressure gauges, although perhaps affected to some extent by the location of the gauges near horizontal braces at the strut ends, were less than half of the reaction forces predicted from calculations. Although cracks of several millimeters were formed at the slope surface near the shoulder, there was hardly any settlement or deformation to hinder passage of trains during construction.

To suppress base failure through rigidity and strength of sheeting walls in the case of ground conditions such as (D) where the thickness of deposits of very soft soil is large would require extremely great rigidity and strength in order to obtain equilibrium below the excavated bottom and is excessively uneconomical. In such cases, the first consideration should be to reduce the design depth of excavation so

that work may be executed at  $N \leq 4$  or at worst  $N \leq 5$ .

An underground bowling center was planned underneath the baseball field of Tokyo Stadium (thickness of very soft alluvial clayey soil stratum: 29 m) and the original plan for excavation to a depth of G. L. -7.5 m at  $N = 6.2$  was altered to a depth of G. L. -6.5 m upon reconsideration of space for piping, depths of beams and earth cover for the underground structure. Further, by scraping 0.5 m of soil from the portions of the ground beyond the slope shoulders affecting base failure (width: 20 m) with bulldozers, excavation was made possible by open cut at  $N = 5.0$ . Even so, when excavation reached bottom, cracks of 2 to 3 mm were noticed to have formed 15 to 20 m beyond the shoulders indicating that the safety factor against base failure was at the very limit. Whenever permissible it is most economical to alter plans in this manner.

In the floating island method, when excavating locations with ground conditions such as (C) and (D), the principle of preventing movement of surrounding ground and base failure through rigidity and strength of sheeting walls is adopted, but when necessary, the weight of the superstructure can be applied to alleviate the shearing stresses within the ground. In actual practice, by performing excavation in subdivided portions, the work can be carried out to match given conditions Fig. 16. Fig. 18 shows an example of excavation performed by the floating island method, which enables safe operations except in cases of extraordinarily poor ground conditions.

The present focal point of Japanese technology is to construct the sheeting walls provided in advance around the perimeter of the site to serve as the structural wall of the building. In Japan, where earthquakes must be considered, it is required for underground walls to have the capacity to serve as shear walls; therefore the vertical joints must be capable of transmitting shear forces. Including waterproofing, schemes such as indicated in Fig. 19 and Fig. 20 are being implemented. Also efforts are being made to improve the verticality of the units and besides using the ICOS method, Soletanche method, Else method, and C. C. F. method introduced from Europe, several original Japanese excavating devices have been developed.

### 3. MEASUREMENTS OF BOTTOM HEAVE CAUSED BY EXCAVATION

Generally speaking, when constructing underground floors, the stresses in the ground are subject to the influences of removal of load through excavation and application of load through construction of the building. In the case of very soft ground, the effects appear as plastic phenomena such as base failure, lateral movement of surrounding soil and settlement of surface, but even if the foundation is made to reach hard ground preventing these phenomena, when the depth of the underground floors is great, heave-up of the bottom of excavation due to removal of load and settlement caused by application of load are of a degree which cannot be neglected. In ordinary open cut methods, the weight of a building is applied to ground which has completed bottom heave, and construction of the building is commenced from that point. But in the floating

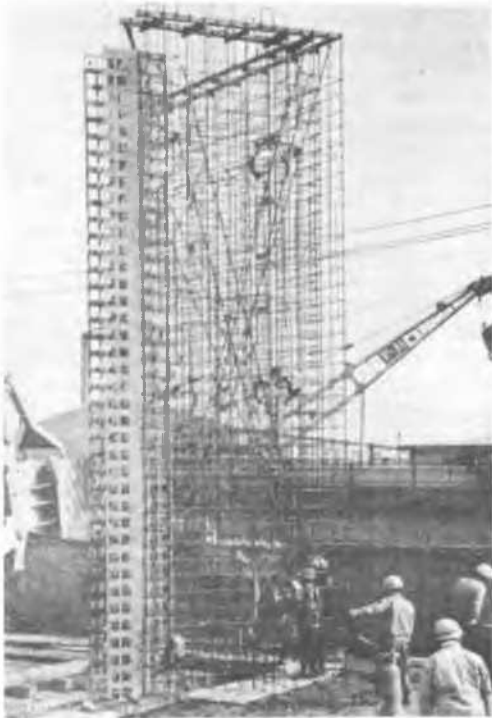

Fig. 19. View of Assembled Steel Bars with Vertical Joints of Cast-in Place Concrete Walls

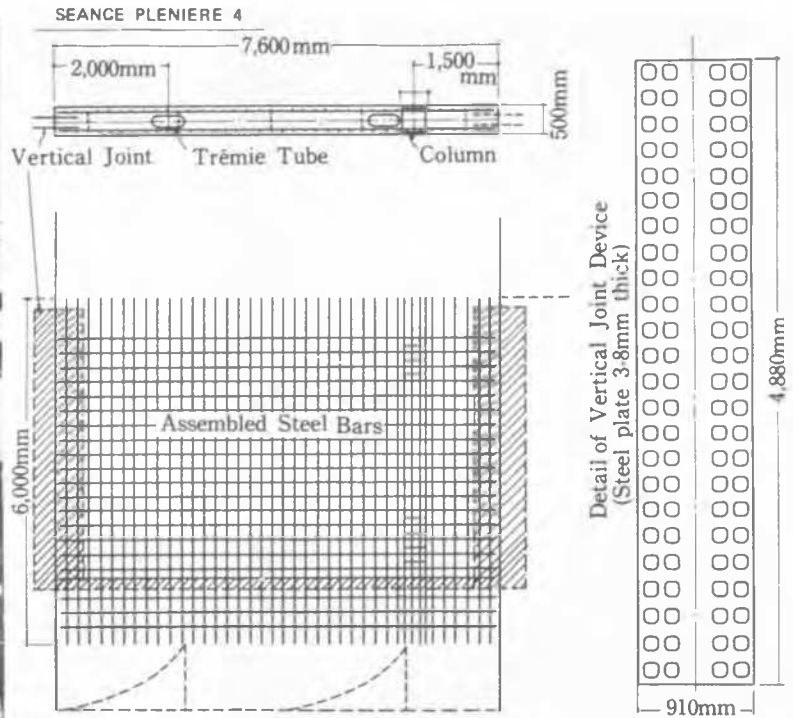

Fig. 20. Vertical Joints of Cast-in Place Concrete Walls

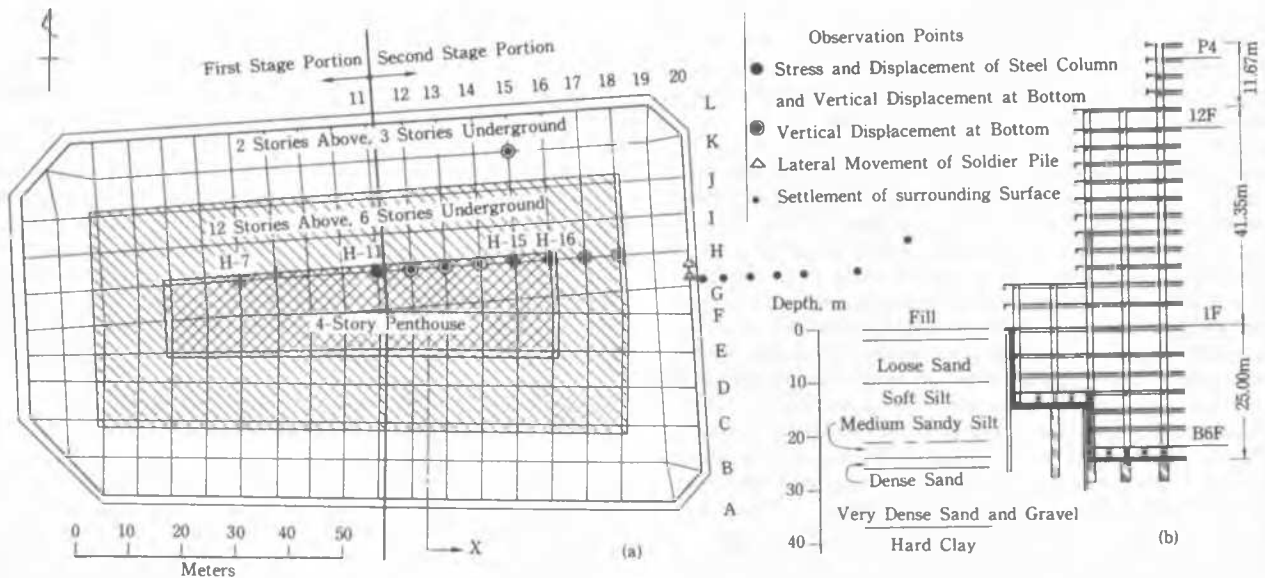

Fig. 21. A Building Near Osaka Station; (a) Plan and Observation Points, (b) Section and Soil Strata

island method, the ground is excavated while the building is being constructed, so that the building is affected from the stage of heave-up. Fig. 21 to 24 are examples of floating island methods while Fig. 25 and 26 are examples of open cut methods. Fig. 21 shows a building 12 stories above ground, 6 stories underground with an excavation depth to G. L. -25 m, now in its second stage of construction near Osaka Station. In this building all concrete placement of

the western half was completed in May 1968 as the first stage of the project. Fig. 22 gives the displacements of the steel building columns observed at the center of the first stage building and at the boundary with the second stage portion (cf. Fig. 21), and the increases or decreases in the loads acting on the excavated surface, as a function of time. In this case, the load removed by the excavation was  $40 \text{ t/m}^2$ , while the load applied by the total weight of the struc-

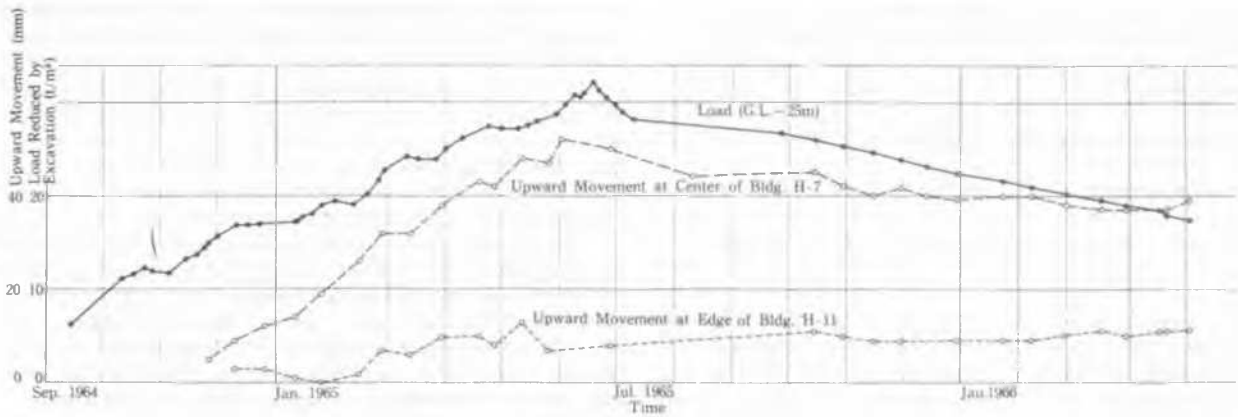

Fig. 22. Load Reduced by Excavation and Vertical Displacement at G.L. -25.0m (See Fig. 21.)

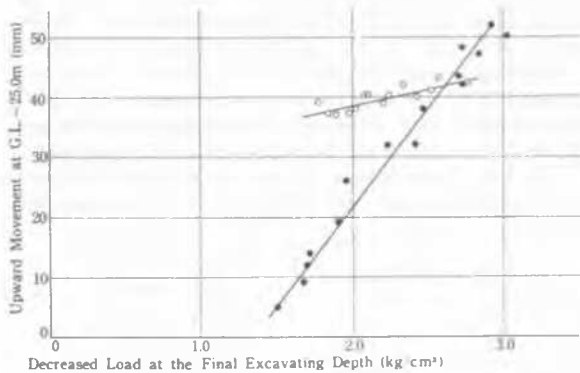

Fig. 23. Relation between Decreased Load and Upward Movement at G.L. -25.0m (See Fig. 21.)

ture was  $21.4 \text{ t/m}^2$ , but in Fig. 22, it is shown that the maximum load removal was held to  $32 \text{ t/m}^2$  as there was a load of  $8 \text{ t/m}^2$  of the building applied at the time of final excavation due to the floating island method adopted. This observation was started after excavation was half completed and it is thought bottom heave was actually even greater. In Fig. 23 it is shown that the relation between load and displacement of the structure is plotted to be roughly linear for the various observation points. According to this, bottom heave is shown to have occurred at a rate of  $3.3 \text{ cm per } 1 \text{ kg/cm}^2$  of load removal, while settlement was at a rate of  $0.45 \text{ cm per } 1 \text{ kg/cm}^2$  of load application. It is noteworthy that the rate of displacement during load application is smaller than that during load removal. Fig. 24 gives the measurement results obtained in the ground at the center of the second stage portion of the building due to second stage excavation after the bottom had been reached. This figure shows that the major cause of bottom heave is the expansion of the clay stratum in the underlying ground with the influence noticeable to a considerable depth. Fig. 25 gives the records of displacements occurring in the second stage construction at the time of completion of second stage excavation. It is interesting to note that the end of the first stage structure had been lifted, the amount of heave on the first stage side thought to have occurred in the first stage had been reduced, and that the sur-

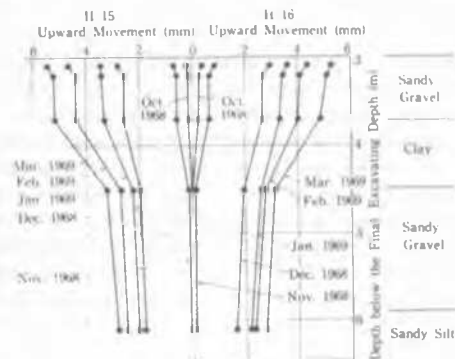

Fig. 24. Time v.s. Upward Movement below the Final Excavating Depth (See Fig. 21.)

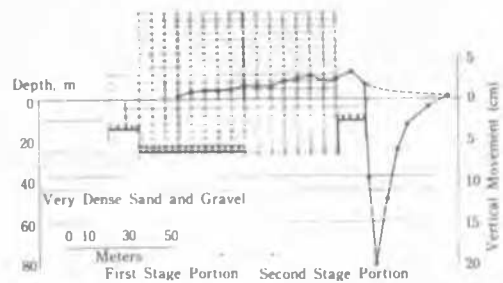

Fig. 25. Vertical Movement at the Time of Completion of the Second Stage Construction (See Fig. 21.)

rounding ground had settled 20 cm.

Another example is a building indicated in Fig. 26 constructed on a tableland with a high-rise portion 17 stories above ground and a low portion 3 stories high, the foundation level of the high-rise portion being G. L. -16.5 m and that of the low portion being G. L. -15 m. In order to preclude adverse effects of the joint between the high-rise and low portions in construction of the building, measurements were made of displacements at the bottom of excavation and at 7 m, 13 m, and 20 m below the bottom when excavating by the open cut method. Further, the displacements caused by increasing loads during construction were measured. The results were as shown in Fig. 27 and it was considered that the relationship between increase and

decrease in load and the displacement,  $\rho$ , of the excavation bottom could be approximated by the equations given below for the periods of bottom heave and of settlement.

$$\text{Bottom heave: } P_H = \frac{1720}{1210} (1 - e^{-\sqrt{2t}}) \sigma \text{ --- (1)}$$

$$\text{Settlement: } P_S = \frac{1700}{540} (1 - e^{-\sqrt{2t}}) \sigma \text{ --- (2)}$$

where t: number of days elapsed since application of  $\sigma$

As a result, placing of concrete at the joint between the high-rise portion and the low portion was deferred until concrete of the high-rise portion had reached the tenth floor above ground.

4. EFFECTS OF EXCAVATION ON BUILDINGS IN SURROUNDING AREA

The Toko Building is a small-scaled building at Hibiya, Tokyo, with one basement floor and 8 floors above ground, a fairly rigid reinforced concrete building constructed in the 1920's. The foundation of pine piles, as shown in Fig. 28, reaches a stratum underlying the alluvial deposit, but it is questionable whether the foundation work was adequate. A subway project was carried out close by under the road in front of this Toko Building as shown in Fig. 29, while excavation for another building was performed to a

depth of -18 m in an adjacent lot. In both of the new projects, the best methods available at the present stage of technology were employed to reduce effects in the neighboring properties. In the subway project, the pneumatic caisson method was used, while in the adjacent building project, a continuous rigid sheeting wall 60 cm thick constructed by the ICOS method was built in advance to a depth of G. L. -20 m with four stages of struts provided during excavation.

During the entire period the settlement of the building was observed from an immovable point using optical levels and water levels. The result was a maximum settlement of approximately 50 mm as shown in Fig. 30. The observations indicated very clearly the manner in which the influences of the construction work were manifested during each period of the construction. These observations show that there is some effect on the surrounding area even when methods considered to have minimal effects are employed. As indicated in Fig. 30, in the adjacent excavation work with foundation concrete 60 cm thick placed leaving a small sump pit, settlement was not stopped, the settlement ceasing only after waterproofing concrete was placed and the excavation bottom was completely sealed. This is a phenomenon which raises the consideration that settlement of surrounding ground is comple-

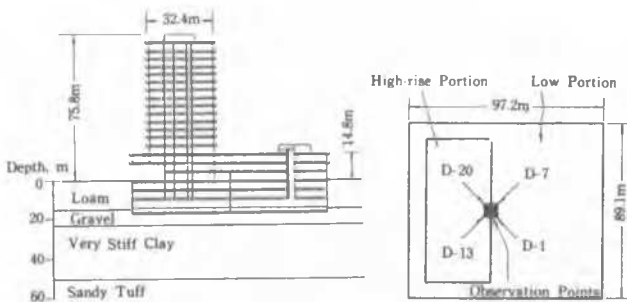

Fig. 26. Plan, Section, Soil Strata and Observation Points

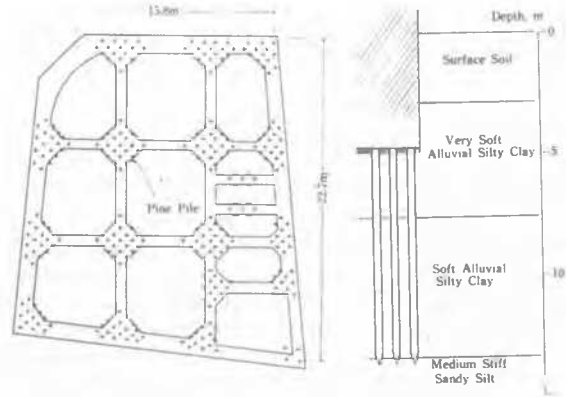

Fig. 28. Foundation Plan and Section of Toko Bldg.

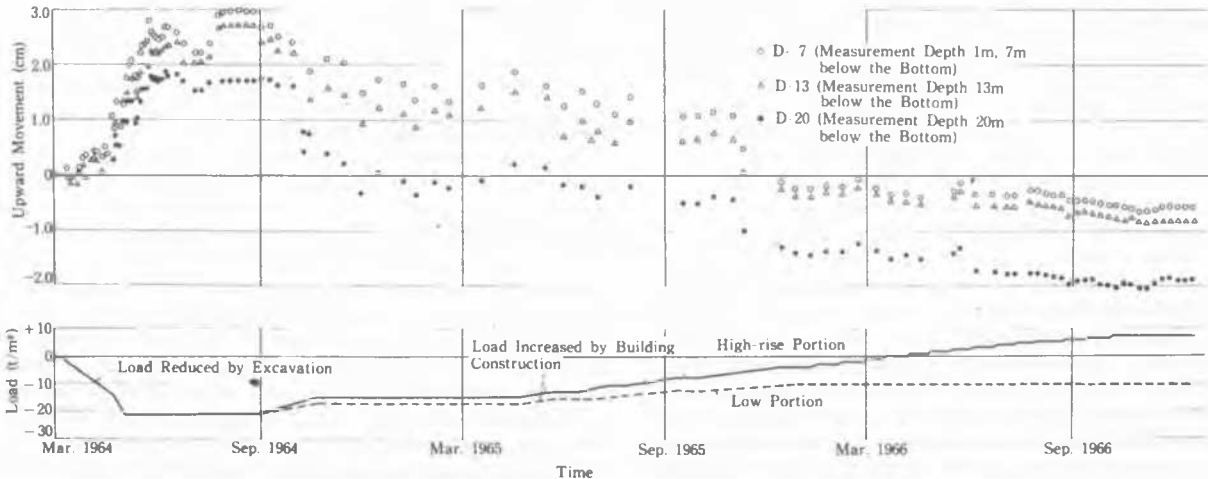

Fig. 27. Variation with Time of Vertical Movements and Load Reduced by Excavation (See Fig. 26.)

## MAIN SESSION 4

tely stopped only after pore water pressures are sufficiently mobilized. Actually, on the whole, there were no adverse effects at all on the Toko Building.

## 5. CONCLUSIONS

In excavation work, the greatest difficulties are encountered when excavations are made by methods accompanied by danger of base failure in ground deposited with more than 10 m of very soft alluvial clay, Case(C), or in ground with thickness of alluvial clay stratum exceeding 20 m, Case(D). In Case(C), surrounding sheeting walls can be made rigid and strong to cope with the problem, but in Case(D) this method becomes extremely uneconomical.

If possible, it would be most economical and de-

sirable to change the design to obtain  $N < 5$ , but when this is not feasible, the only solutions would be to reduce relative  $\overline{FH}$  by applying loads to the areas surrounding the excavation surface, carrying out soil stabilization to increase  $S_u$  and obtain  $N < 5$  or increasing  $N_{cb}$  by trench cuts and partial excavations. However, in the last case, there is danger of considerable deformation and settlement occurring in surrounding ground and the utmost caution must be exercised.

With the floating island method now widely used in Japan, one proceeds with excavation while constructing the building from the ground surface downward, and other than in cases of exceptionally adverse conditions, the method is adaptable to most cases due to ease of limiting lateral movements of the surrounding ground through the use of rigid walls, partial excavation, and by providing reaction against the building structure.

However, when the depth of excavation is great and there is an underlying clay stratum, this method will be subjected to the effects of bottom heave and settlement so that in buildings with high-rise and low-storied portions or buildings constructed in two stages, it is necessary to study methods of constructing joint sections which will not cause harmful stresses in the building structures.

When carrying out excavation work on ground of (C) or (D) category in the neighborhood of buildings with inadequate foundations, there is fear of adverse effects of excavation regardless of the type of excavation method due to changes in pore water pressures in the ground. However, it may be said that workmanship has a great effect on settlement and it is most import-

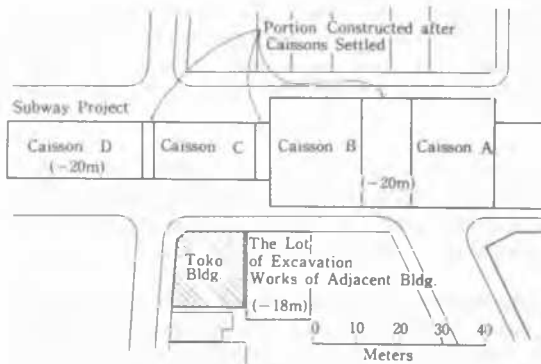

Fig. 29. Underground Constructions around Toko Bldg.

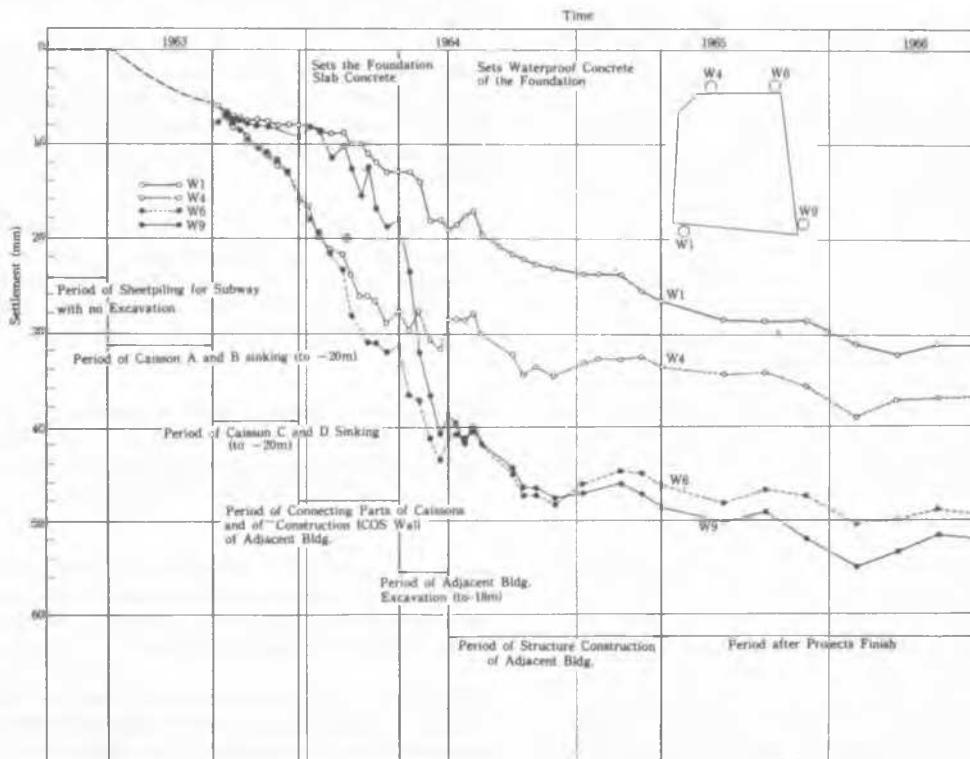

Fig. 30. Settlement of Toko Bldg

ant in this case to secure careful work.

ing of Architectural Institute of Japan.

## ACKNOWLEDGEMENTS

The author's utmost thanks are due to Messrs. T. Kawasaki, T. Hashiba, U. Ikuta, M. Niwa and T. Morita for furnishing data for preparation of this report. Also, the author wishes to sincerely thank Dr. Y. Yoshimi and Messrs. M. Tomono, Y Suzuki and M. Kondo for their special cooperation in the work.

## REFERENCES

- BJERRUM, L., and O. BIDE (1956). Stability of Struttred excavations in clay, "Geotechnique, 6, No. 1, pp. 32-47.
- ENDO, M., and U. TAKAHASHI (1962). Measurement of earth pressure acting on the struts of cofferdam, for sandy strata, (in Japanese), Technical Report of Takenaka Technical Research Laboratory, June, No. - 590
- ENDO, M., (1968). "Current of recent foundation construction methods, " (in Japanese) , Journ. of Architecture and Building Science, Architectural Institute of Japan, Nov., PP. 777-781.
- ENDO, M., and U. IKUTA (1965). "A study of foundation works of NKK ironworks in Fukuyama, " (in Japanese), Technical Report of Takenaka Technical Research Laboratory, Spt., No. 912.
- ENDO, M., and T. KAWASAKI (1960). "A Study of excavation method of Kinshicho Station Bldg.," (in Japanese), Technical Report of Takenaka Technical Research Laboratory, No., 368, No. 373, No. 400.
- ENDO, M., T. HASHIBA, and T. OUCHI (1969). "An observation on an ultimate bearing capacity of silty clay. "Soils and Foundations, Vol. IX, No. 4, Dec. (Intended).
- ENDO, M., U. IKUTA and H. NAKAZAKI (1969). "Experimental study of volume change behavior in partially saturated clayey layer during construction period, " (in Japanese) Takenaka Technical Research Report, No. 4.
- ENDO, M., T. KAWASAKI, and K. YAMAMOTO (1966) "Measurement of settlement of Toko Bldg. affected by adjacent excavation works, " (in Japanese), Technical Report of Takenaka Technical Research Laboratory. Sept. No. 1019
- ENDO, M., T. KAWASAKI, Y. IKUTA, and Y. KIMURA (1969). "An experimental study of vertical joints for continous basement walls," (in Japanese), Transaction of the annual meet
- ENDO, M., T. KAWASAKI, Y. IKUTA, and Y. KIMURA (1969). "An experimental study on connecting properties between continous basement walls and structures of building," (in Japanese), Transaction of the annual meeting of Architectural Institute of Japan, Hokkaido.
- HASHIBA, T., M. NIWA, and F. YOSHINAGA (1968) "Measurement of surrounding ground displacement of Osaka Fiber Wholesale Center Bldg., " (in Japanese), Technical Report of Technical Dept. of Osaka Main Office, Takenaka Komuten Co., Ltd.,
- KAWASAKI, T., T. HASHIBA and Y. MENDE (1969). "Discussions on the Takenaka Deep Foundation Process from standpoint of soils engineering, " (No. 1, No. 2) (in Japanese), Technical Report of Takenaka Technical Research Laboratory No. 1268, No. 1293.
- KITAZAWA, G., T. TAKEYAMA, K. SUZUKI, H. OGAWARA, and Y. OSAKI (1959). Tokyo Jibanzu (Subsoil maps and profiles of soils in Tokyo) (in Japanese), Gihodo, PP. 113.
- KINKI BRANCH of Architectural Institute of Japan, and Kandai Branch of Japanese Society of Soil Mechanics and Foundation Engineering (1966). Osaka Jibanzu (Subsoil maps and profiles of soils in Osaka), (in Japanese), Corona-Sha.
- KINKI BRANCH of Architectural Institute of Japan, (1967). "Muon mushindo kishohoho" (Construction methods of foundation with little noise and vibration), Text Book of a training course.
- NIWA, M., and T. MORITA (1969) "Measurement on the surrounding settlement due to deep excavation at the No. 1. Bldg. for City of Osaka " (in Japanese), Technical Report of Technical Dept of Osaka Main Office, Takenaka Komuten Co., Ltd.
- OUCHI, T., (1951). "Open caisson process of Nikatsu International Bldg., " (in Japanese), Journ. of Architecture and Building Science, Architectural Institute of Japan, Oct. PP. 1-10.
- OUCHI, T., (1961). "Study of the sinking behavior of caisson process in silty soils", (in Japanese), Dr. Eng. Thesis, Tokyo Institute of Technology, Tokyo.
- TAKAGI, M., K. SHIMIZUGAWA, and U. IKUTA (1969). "Report of the works by Takenaka Basement Wall Method," (in Japanese), Seko, Syokoku-Sha, April 1969, PP. 27-42.

TERZAGHI, K., and R. B. PERCK (1967). Soil mechanics in engineering practice, 2nd Edition, John Wiley and Sons, Inc., New York.

## A P P E N D I X

List of Typical Japanese papers concerned Earth Pressure, Movement of Surrounding Soils and Cofferdam in Japanese.

AMIMOTO, K., OKAMOTO, T. and YAMADA, S. (1958), "Measurement of Earth Pressure Acting on Side Walls of Subway Construction", Journal of the Japanese Society of Soil Mechanics and Foundation Engineering, No. 34, pp 21-30.

ABOSHI, T., OZAWA, A. and KUSUMOTO C. (1966), "On the Measuring Method of the Deflection and Stress in a Quay Wall by Using a Inclino meter", Proceedings of the 20th Annual Meeting of Japan Society of Civil Engineers, 3, pp 53.

ANBIRU, T. (1961), "Some Consideration Connected with the Measured Strut Loads (in Sand)", Trans. of the Architectural Institute of Japan, Oct., No. 69, pp 777-780.

ICHIHARA, M., TABATA, K. and KONDO, M. (1966), "Measurements of the Earth Pressure and Tensile Load of Tie-Rods Acting on the Yamano shita Quay before and after Niigata Earthquakes", Journal of the Japanese Society of Soil Mech. and Foundation Engineering, Mar., No. 97, pp 13-22.

KATAYAMA, A., IGUCHI, H., (1961), "Measurements of Earth Pressure Acting on a Reinforced Concrete Sheet Pile", Journal of the Japanese Society of S. M. and F. E., Aug., No. 46, pp 4-II.

KOTODA, K., MINOU, A., ENDO, M. and KAWASAKI T. (1959), "Measurements of Lateral Earth Pressure by Strut Load (in Cohesive Soil)", Trans. of the Architectural Institute of Japan, Oct., No. 63, pp 689-692.

KOTODA, K., YAMASHITA, J., (1959), "Experimental study on the Movement of Sheet Pile with Model in Sand", Journal of Japanese Society of S. M. and F. E., Aug., No. 34, pp 4-9.

KOTODA, K., OKI, N., (1968), "Comparison of Observed Strut Loads with Proposal Value of Terzaghi and Peck (1967)", Proceedings of the Annual Meeting of the Architectural Inst. of Japan, pp 641-642.

KOTODA, K., KANATANI, Y., MIYAZAKI, Y. and HANAMURA, M. (1968), "Experimental Study on the Movements of Sheet Piles in a Excavation

without Struts", Proc. of the 3rd Annual Meeting of the Japanese Society of S. M and F. E., pp 499-502.

ODA, T. and OSANAI, S. (1963), "Measurements of the Earth Pressure and Tie-Rod Loads of the Quay Wall at Kushiro Port", Journal of the Japanese Society of S.M. and F.E., Oct., No. 68, pp 19-26.

YAMAGATA, K., NAKATA, K. and FUKUMOTO, K. (1966), "Measurements of the Strut Loads and Movements of Surrounding Soils During Excavation", Journal of the Japanese Society of S.M. and F.E., Mar., No. 97, pp 29-36.

YAMAGATA, K. and YAO, S. (1967), "Variation of the Earth Pressure Acting on the Cofferdam Consist of Steel Pipe Piles during Excavation (Part-I)", Journal of the Japanese Society of S.M. and F.E., May, No. III, pp 29-38.

YAMAGATA, K. and YAO, S. (1967), "Variation of the Earth Pressure Acting on the Cofferdam Consist of Steel Pipe Piles during Excavation (Part- II)", Journal of the Japanese Society of S.M. and F.E., Jun., No. II2, pp 7-16.

Chairman O. MORETTO

Thank you very much Dr. M. Endo for your very interesting contribution.

The next contribution will be in charge of Dr. Alberro of the Instituto de Ingenieria of the Universidad Nacional Autónoma de México.

Panelist J. ALBERRO (Mexico)

## INTRODUCTION

Lors de la construction du métro de la ville de México, la réalisation d'une campagne de mesures de chantier a été décidée. Il a été convenu d'installer des appareils de mesure des déplacements, provoqués dans le terrain par le processus d'excavation, ainsi que des vérins plats et des piézomètres dans les murs latéraux du tunnel afin de connaître la distribution des pressions horizontales. Les résultats obtenus sont satisfaisants et permettent d'analyser la distribution des déplacements et des contraintes sur le pourtour du tunnel.

Avant de présenter quelques-uns des résultats obtenus, il convient de décrire de façon succincte les caractéristiques du sous-sol de la ville de México ainsi que les méthodes d'excavation utilisées.

CARACTERISTIQUES DU SOUS-SOL DE LA VILLE DE MEXICO



Le sous-sol de la ville de Mexico est formé de dépôts lacustres, d'origine volcanique. En surface, on trouve des dépôts de sable silteux ou des remblais artificiels de 2 à 5 m d'épaisseur en général, où l'on trouve le niveau phréatique, suivis d'une couche argileuse de 10 à 30 m d'épaisseur, formée de cendres volcaniques très compressibles et veinée de minces couches de sable. La teneur en eau de cette couche argileuse est en moyenne de 280 pour cent et ses limites de liquidité et de plasticité sont égales respectivement à 290 pour cent et 85 pour cent en moyenne. Son indice des vides est de 7. Il s'agit de plus d'une argile sensible au remaniement (indice de sensibilité égal à 8). La résistance à la compression simple des éprouvettes d'argile non remaniée est en moyenne de  $0.8 \text{ kg/cm}^2$ .

#### PROCEDES D'EXCAVATION

La profondeur d'excavation varie entre 6 et 8 m en général, sauf pour quelques cas particuliers tels que les croisements avec le réseau de drainage de la ville. Dans ce cas, la construction du siphon nécessaire au rétablissement de la continuité du collecteur de drainage requiert une excavation de 10 m de profondeur environ. La stabilité des parois de l'excavation a été obtenue suivant les cas au moyen de talus ou de palplanches étayées, soit métalliques soit de béton moulé dans le sol. La longueur de fiche des palplanches est variable. Les étais des excavations ont été préchargés, lors de leur mise en place, à 30 tonnes environ pour les étais proches de la surface et à 90 tonnes pour les étais profonds. Ceci correspond à des charges de 6 et 18 tonnes par mètre linéaire d'excavation.

L'excavation s'est faite à partir de la surface du terrain au moyen de pelles mécaniques sauf rares exceptions. Les filtrations ont été contrôlées au moyen de pompes et souvent par électrosmose.

#### APPAREILS DE MESURES

Le long de la ligne No. 1 du métro, trois stations de mesure ont été installées. Chaque station comporte le long de la paroi verticale du tunnel 4 vérins plats du type Freyssinet, 4 piézomètres pneumatiques placés aux mêmes élévations que les vérins plats et pour l'une des stations un extensomètre transversal de la Slope Indicator, Co. avec 2 éléments sensibles.

Le long de la ligne No. 2 du métro, ont été installées 2 stations de mesure du même type que pour la ligne No. 1. Sur la ligne No. 3, actuellement en construction, une station de mesure est déjà en place. Le schéma de l'installation type d'une station est présenté dans la fig 1.

De plus, le long du tracé des lignes ont été installées des références topographiques qui permettent un relevé des déplacements du terrain, lors de l'excavation.

#### DEPLACEMENTS DU TERRAIN SUR LE POURTOUR DE L'EXCAVATION

Il est communément admis que le fond d'une fouille se soulève du fait de la charge induite par l'excavation. Ce phénomène est à court terme élastique, et la fig 2 en présente un cas, analysé à l'aide du diagramme construit par N.M. Newmark. La comparaison des déplacements verticaux du fond de fouille calculés par cette méthode et mesurés directement est très satisfaisante.

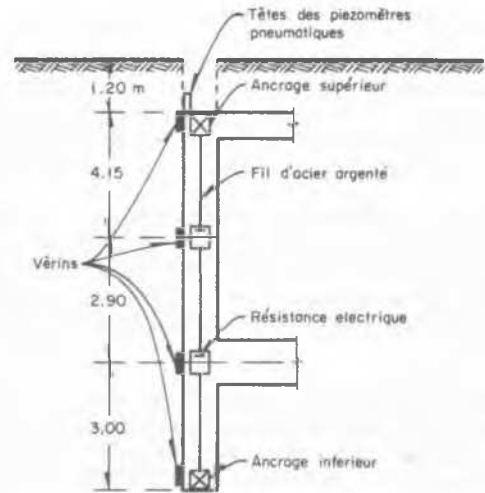

Fig 1 Coupe du tunnel. Localisation des appareils de mesure

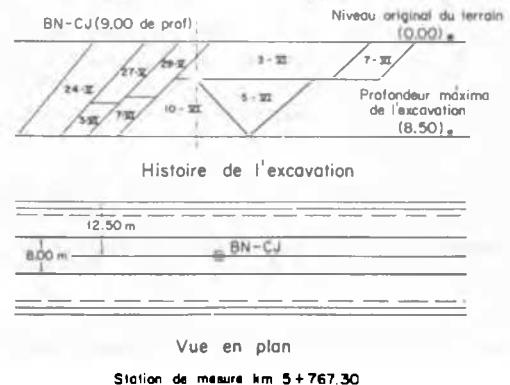
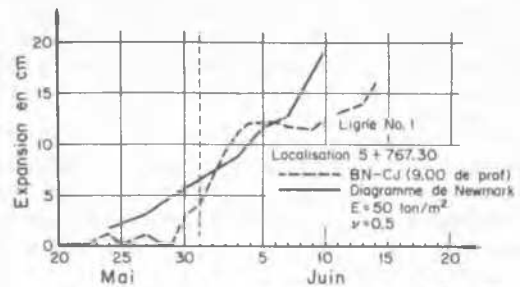

Fig 2 Déplacements verticaux en fonction du temps

Il est aussi, non moins communément admis que la surface du terrain aux alentours de l'excavation s'affaisse. Il faudrait cependant, à ce propos, préciser, il me semble, la durée du processus d'excavation et

de pompage. En effet, à long terme, le pompage provoque une consolidation du terrain et par conséquent un tassement de la surface. Mais, instantanément et en accord avec les résultats de la théorie élastique, le mouvement doit être un soulèvement des alentours de l'excavation. La fig 3 présente la configuration des déplacements de la frontière de l'excavation, d'après un exemple traité par la méthode des éléments finis.

Ces soulèvements instantanés ont été observés dans la pratique, lors de l'exécution des excavations du metro de la ville de Mé-

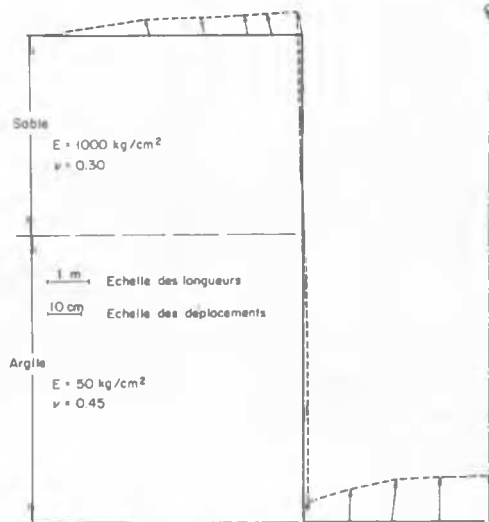

Fig 3 Déplacements du pourtour de l'excavation. Méthode des éléments finis

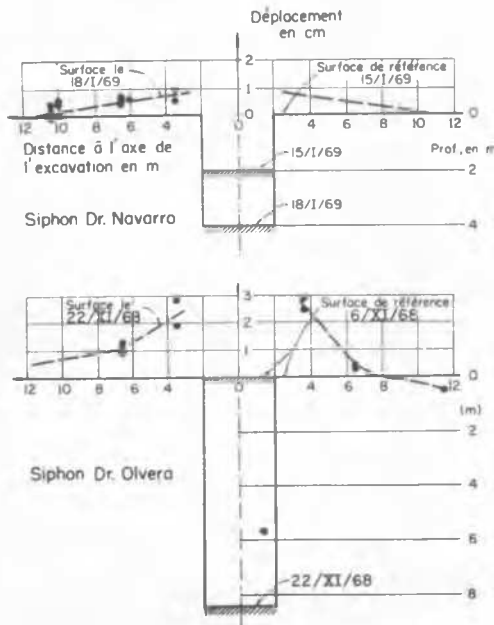

Fig 4 Expansions à proximité des excavations

xico. La fig 4 en présente deux exemples, tirés des mesures faites lors de l'excavation avec des palplanches métalliques de deux siphons<sup>1</sup>. De même, la fig 5 résume les mesures faites pendant la construction des immeubles du Centre Urbain "Presidente Juarez". Dans ce cas, la pente du talus de l'excavation de 6 m de profondeur et de 18 m de largeur, était égale à 0.75/1.

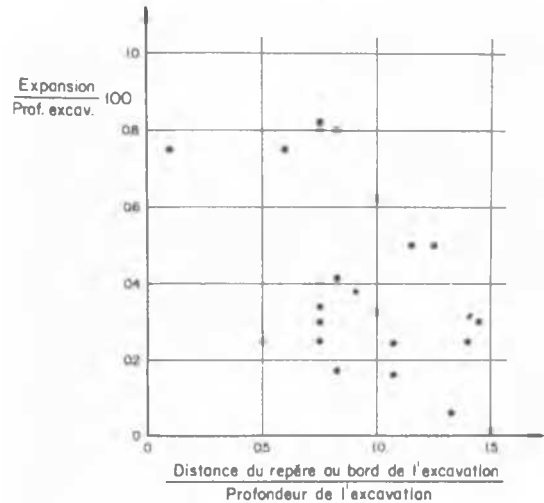

Fig 5 Expansions à proximité des excavations. Centre Urbain Presidente Juarez

Ces exemples montrent qu'à court terme les mouvements d'expansion élastique à proximité de l'excavation ne sont pas négligeables. Leurs effets sont divers et, en ce qui concerne les excavations dans la ville de Mexico, on leur attribue la naissance de fissures de tension, aussi bien dans la zone du fond de fouille que dans les talus et les zones proches des excavations.

Ces fissures à leur tour, peuvent modifier radicalement la forme des surfaces potentielles de rupture, qui dans de nombreux cas deviennent des plans passant par le pied du talus<sup>2</sup>.

Pour restreindre l'ampleur de l'expansion élastique du fond de l'excavation on a souvent utilisé des pieux ancrés à grande profondeur et fichés dans le terrain avant de procéder à l'excavation. Dans ce cas, les mouvements d'expansion sont fortement réduits, l'argile adhère aux pieux qui à leur tour induisent dans le terrain des efforts tranchants dirigés vers le bas. Cette restriction des mouvements élastiques due à la génération d'efforts tranchants entre terrain et pieux influe sur la valeur des poussées latérales.

PUSSEES LATERALES SUR LES ETAIS DES EXCAVATIONS

Les poussées latérales sur les étais des excavations creusées dans l'argile, suivent des lois différentes d'après la valeur du coefficient de stabilité  $N_s$ .

Lorsque la résistance du sol, comprise entre la surface du terrain et le fond de

la fouille, n'est pas prise en compte, on démontre théoriquement que, dans le cas d'un problème à deux dimensions, le terrain commence à se plastifier près du fond de l'excavation lorsque  $N_b = 3.14$ . Pour une valeur de  $N_b$  égale à 5.14, la rupture se produit. Pour un problème à 3 dimensions la valeur de  $N_b$  qui correspond à la rupture varie entre 6.2 et 9.1. Nous pouvons donc considérer que pour  $N_b$  inférieur à 4 ou 5 le problème posé est essentiellement élastique, alors que pour  $N_b$  supérieur à 6 le problème doit être traité par la théorie de la plasticité.

1. Excavations dans les argiles avec  $N_b < 4$  ou 5.

Dans ce cas, il est raisonnable de traiter le problème au moyen de la théorie de l'élasticité. C'est ce qui a été fait pour interpréter les résultats de poussées latérales obtenus avec les stations de mesure du métro de la ville de Mexico.

L'exemple présenté dans les figs 6 à 9 correspond à une des stations de mesure de la ligne No. 1, placée à hauteur de la rue Medellín. L'excavation de 7 m de profondeur a été découpée dans un terrain essentiellement argileux. La fig 6 présente la coupe stratigraphique du sous-sol à cet endroit. La cohésion de l'argile y est égale en moyenne à 2.5 t/m<sup>2</sup> et le coefficient de stabilité  $N_b$  vaut 3.6. L'excavation, flanquée de deux murs de béton moulé dans le sol, a été étayée à 2.00, 4.00 et 5.50 m de profondeur. La fig. 7 représente la structure du tunnel terminé et l'on peut y distinguer clairement le caisson intérieur flanqué des deux palplanches en béton armé. La rigidité des palplanches est égale à  $239 \times 10^2 \text{ t/m}^2/\text{m}$ . Les résultats des pressions totales, mesurées à l'aide des vérins plats scellés dans les murs moulés, sont présentés dans la fig 7. On peut y remarquer la très faible dispersion des valeurs enregistrées à 4 et 10 m de profondeur du 7 Juin au 25 Juillet 1968. Les valeurs de la pression horizontale enregistrée par le vérin supérieur, placé à 1.80 de la surface du sol, sont beaucoup plus variables du fait de la présence à ce niveau d'une rangée d'étais dont la charge a été parfois considérable. Le 24 Juin, par exemple, la rangée supérieure d'étais a été chargée à 30 tonnes.

Il convient de noter aussi la réduction avec le temps des pressions latérales. Des piézomètres furent installés dans une perforation placée à 50 cm du mur moulé et aux mêmes élévations que les vérins plats. Les pressions interstitielles ainsi mesurées ont pu être décomptées des pressions totales. La fig 9 en traduit les résultats. La constance du coefficient de poussée K, calculé en fonction des efforts effectifs, est remarquable, ce qui implique que le diagramme des pressions effectives est triangulaire.

L'exemple présenté dans les figs 10 à 13 correspond à un cas similaire à l'antérieur. Il est intéressant de noter cependant que, bien que la rigidité de la palplanche soit dans ce cas double de celle de

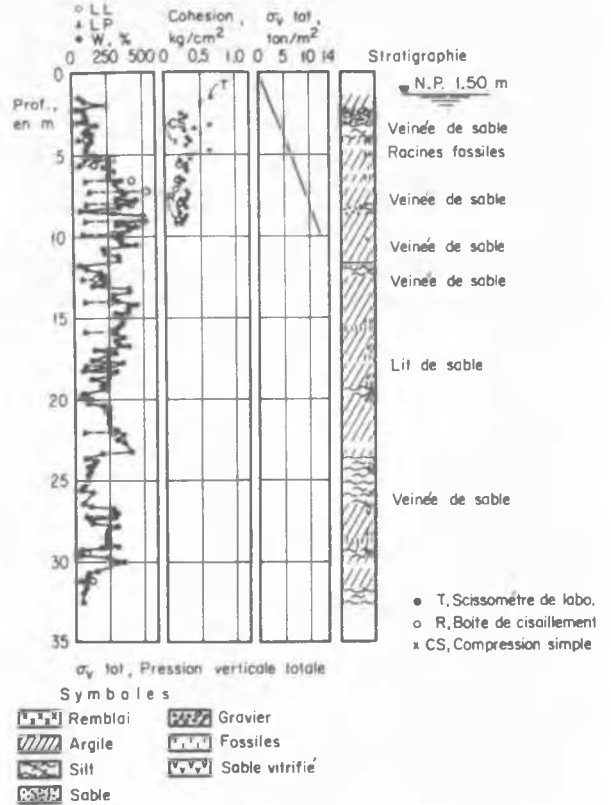

Fig 6 Coupe stratigraphique du terrain. Station de mesures Medellín

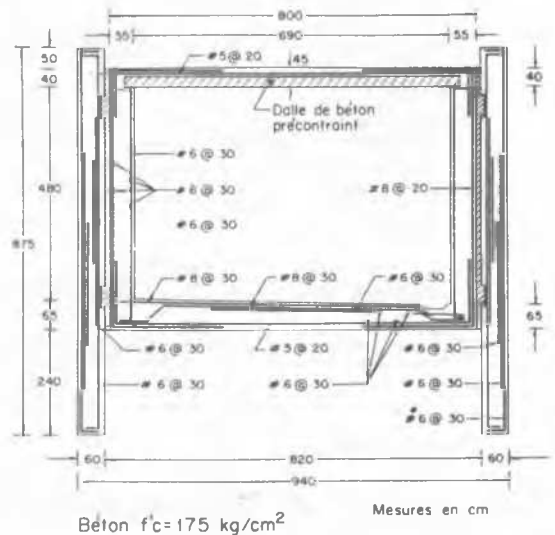

Fig 7 Structure du tunnel. Ligne No. 1. Station de mesures Medellín

l'exemple précédent, les valeurs du coefficient K, calculé en fonction d'efforts effectifs, sont semblables dans les deux cas.

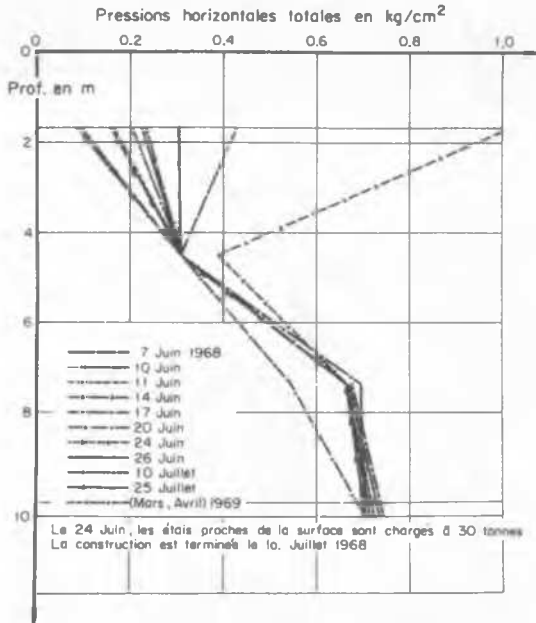

Fig 8 Pressions horizontales totales. Station de mesures Medellin

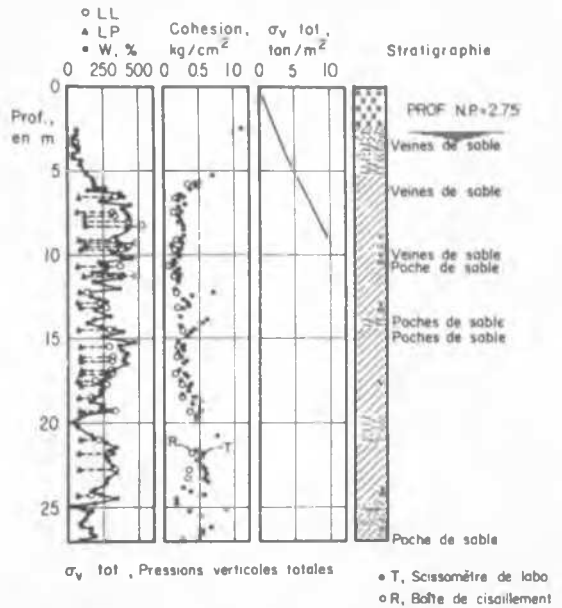

Fig 10 Coupe stratigraphique du terrain. Station de mesures Buenavista

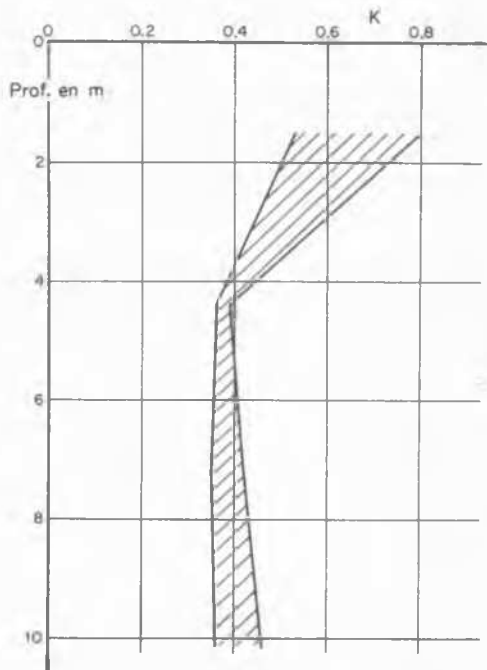

Fig 9 Quotient K des efforts effectifs horizontaux et verticaux. Station de mesures Medellin

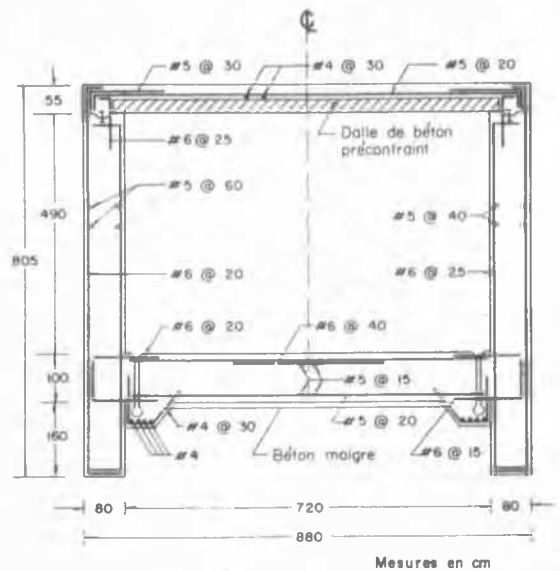

Fig 11 Structure du tunnel. Ligne No. 2. Station de mesures Buenavista

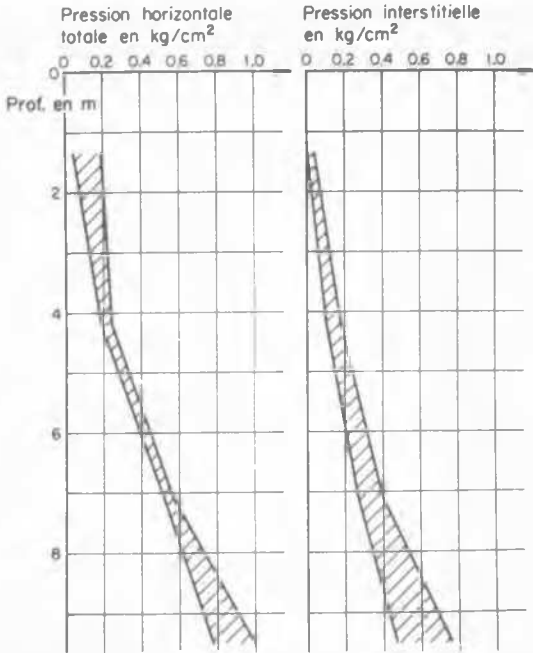

Fig 12 Pressions horizontales totale et interstitielle

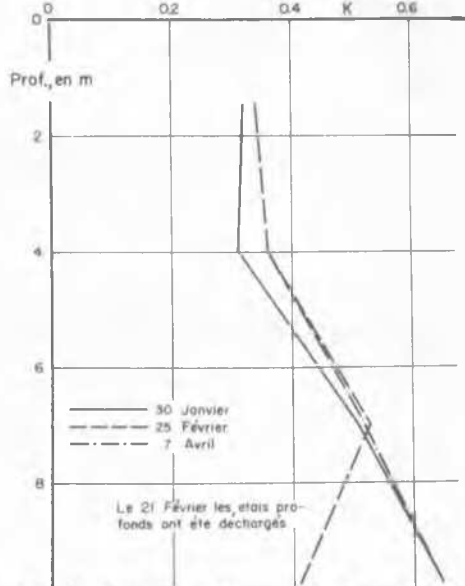

Fig 13 Quotient K des efforts effectifs horizontaux et verticaux

Cette similitude des valeurs du coefficient K est due, semble-t-il, au fait que le terrain se comporte de façon élastique, les déplacements du mur étant faibles. En conséquence, un exemple type d'excavation a été choisi et traité par la méthode des éléments finis. Les valeurs des coefficients d'élasticité des terrains ont été choisies en fonction des résultats de nombreux essais tant de laboratoire que de chantier<sup>24</sup>. La fig 14 en traduit les résultats, relatifs à la distribution des efforts tranchants maxi

ma. On peut y remarquer que la zone limitée par la courbe correspondant à des efforts tranchants maxima de  $3 \text{ t/m}^2$  (ce qui est une valeur moyenne de la cohésion de l'argile), est réduite. En conséquence le comportement est essentiellement élastique.

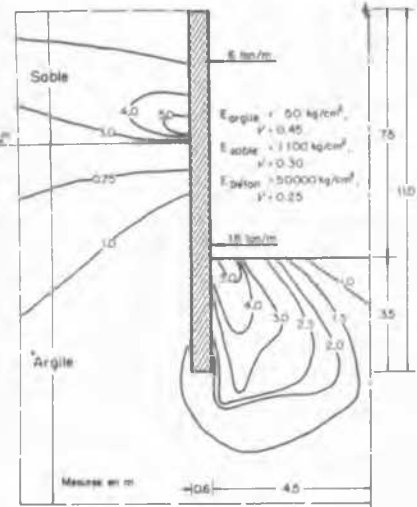

Fig 14 Courbes d'égal effort tranchant maximum en tonnes/m<sup>2</sup>

Les pressions totales calculées par cette méthode, en supposant de plus que le coefficient de poussée au repos de l'argile est égal à 0.5, et que le pompage, du fait de la rapidité de la construction, ne diminue pas les pressions interstitielles dans l'argile, sont présentées dans la fig 15; on y montre aussi les valeurs des pressions totales mesurées directement à la station d'observation de la rue Merida, dont les caractéristiques sont proches de celles choisies pour le calcul.

Les expansions du fond de la fouille, calculées par cette méthode sont égales à 13 cm, alors que l'expansion obtenue par mesure directe (fig 2) est de l'ordre de 15 cm.

Il convient de souligner enfin, l'accord satisfaisant observé entre les déformations du mur calculées et mesurées directement à la station de la rue Merida.

Cette concordance d'ensemble entre le calcul et les mesures directes, confirme la validité du calcul élastique pour des excavations dont le coefficient de stabilité est inférieur à 4.

En conséquence il semble recommandable, pour ces cas, de calculer les poussées réelles, soit par la méthode du coefficient de pression au repos, soit par la méthode des éléments finis. La règle donnée par R.B. Peck suivant laquelle, dans ce cas, les poussées sur les étais peuvent être calculées en supposant une poussée latérale réelle  $p$ , variable entre  $0.2 \gamma H$  et  $0.4 \gamma H$  est probablement valable lorsqu'il s'agit d'argiles saturées, mais avec une

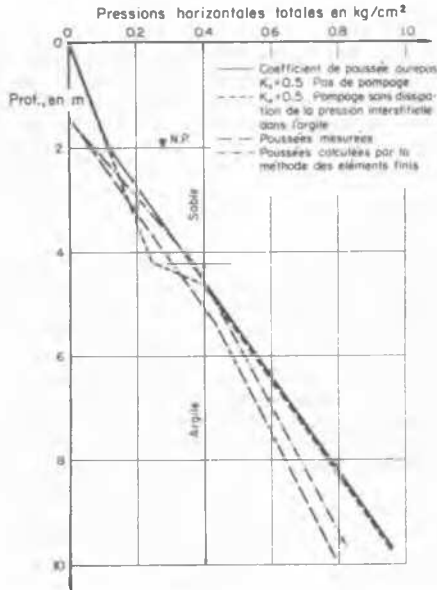

Fig 15 Poussées totales sur les murs latéraux du tunnel

nappe phréatique profonde. Lorsque le niveau phréatique est proche de la surface comme pour le cas des argiles de Mexico il faudrait appliquer la formule:

$$p = \gamma_w h + 0.4 (\gamma H - \gamma_w h) \quad (1)$$

avec

- $\gamma_w$  poids spécifique de l'eau
- $h$  différence d'élévation entre le fond de fouille et le niveau phréatique
- $(\gamma H - \gamma_w h)$  pression verticale effective
- $H$  profondeur de l'excavation.

Il est, en effet, fort peu probable que la poussée en un point du mur soit inférieure à la poussée due à l'eau. Or, s'agissant d'argiles peu perméables, la diminution des pressions interstitielles provoquée par le pompage est à court terme imperceptible.

La formule (1) coïncide avec celle qui correspond à la méthode du coefficient de poussée au repos, avec une valeur du dit coefficient égale à 0.4. La distribution des pressions proposées par R.B. Peck est cependant très différente de celle obtenue par mesure directe ou par la méthode du coefficient de poussée au repos. Il ne faut pas perdre de vue, à ce propos, que la règle empirique de R.B. Peck s'applique aux charges des étais et non aux pressions latérales réelles. Le diagramme des pressions latérales réelles du sol contre le mur peut être triangulaire, sans que le diagramme des charges sur les étais le soit. Cette apparente contradiction est due aux déplacements des appuis des étais pendant la construction. Ces déplacements des appuis provoquent alors une augmentation ou une diminution des réactions des étais.

## 2. Excavations dans les argiles avec $N_b > 5$ .

Lorsque le coefficient de stabilité  $N_b$  de l'excavation est supérieur à 5, il se forme une zone plastique près du fond de l'excavation, zone plastique dont les dimensions augmentent lorsque  $N_b$  augmente, jusqu'au moment de la rupture du fond de fouille.

Les considérations, propres du cas antérieur, ne sont plus valables. Il est nécessaire de se baser, lorsque  $N_b$  est supérieur à 5, sur une théorie de la rupture pour calculer les pressions latérales.

Par la théorie classique de Rankine, on obtient la valeur de la poussée totale:

$$P_a = \frac{\gamma H^2}{2} \left(1 - \frac{4S_u}{\gamma H}\right)$$

- $P_a$  étant la poussée horizontale totale
- $H$  la profondeur de l'excavation
- $S_u$  la résistance au cisaillement non drainé de l'argile
- $\gamma$  le poids spécifique du terrain.

La valeur maxima de la pression latérale apparente, donnée par la règle empirique de R.B. Peck, provient de cette analyse et vaut  $(\gamma H - 4S_u)$ . Avec la distribution des pressions apparentes, proposée par R.B. Peck, la valeur de la poussée totale  $Q$  sur les étais de l'excavation est donc égale à:

$$Q = 1.75 \left[ \frac{1}{2} \gamma H^2 \left(1 - \frac{4S_u}{\gamma H}\right) \right]$$

Il est bien évident que cette poussée totale  $Q$  doit être supérieure ou au moins égale à la poussée de l'eau sur la palplanche, ou à plus forte raison sur le mur moulé dans le sol. En effet la perméabilité du mur moulé dans le sol est très faible. Il faut donc vérifier que:

$$1.75 \left[ \frac{1}{2} \gamma H^2 \left(1 - \frac{4S_u}{\gamma H}\right) \right] \geq \frac{1}{2} \gamma_w H^2$$

soit  $1.75 \left(1 - \frac{4}{N}\right) \geq \frac{\gamma_w}{\gamma}$

Pour le cas du siphon de Morazan<sup>7</sup> pour lequel  $N = 6$  et  $\gamma = 1.2 \text{ t/m}^3$ , il s'avère que cette inégalité n'est pas vérifiée.

La règle empirique de R.B. Peck, dans ce cas, prédit une poussée latérale totale inférieure à celle due à la simple présence de la nappe phréatique. Ce résultat n'est pas digne de crédit, et il serait sans doute recommandable de modifier cette règle de façon à ce que la valeur de la poussée latérale totale soit au moins égale à la poussée de l'eau.

Pour le cas des excavations réalisées dans les argiles d'Oslo et de Mexico, avec  $N > 5$ , les charges des étais ne vérifient pas la règle empirique de R.B. Peck. Les mesures effectuées dans ces cas, montrent que les réactions des étais sont nettement supérieures à celles observées ailleurs.

Cette distribution exceptionnelle des charges sur les étais peut être due uniquement aux déflexions subies par la palplanche

avant la mise en place des étais, sans qu'il soit nécessaire pour autant de considérer une redistribution des pressions latérales réelles sous l'effet des déplacements observés. Dans d'autres cas, ceci a été démontré. Pour vérifier cette hypothèse, la palplanche a été analysée comme une poutre continue, soumise à des butées et poussées calculées par la formule de Rankine et appuyée sur les étais (fig 16); les expressions des charges sur les étais en fonction des déplacements des appuis, qui résultent de ce calcul sont, pour la 4eme étape d'excavation :

$$R_1 = 1.0 + 884 v_1 - 2006 v_2 + 1407 v_3 - 289 v_4$$

$$R_2 = 8.3 - 2006 v_1 + 5436 v_2 - 5140 v_3 + 1735 v_4$$

$$R_3 = 15.6 + 1407 v_1 - 5140 v_2 + 6894 v_3 - 3273 v_4$$

$$R_4 = 39.4 - 289 v_1 + 1735 v_2 - 3273 v_3 - 1932 v_4$$

$$P = 8.7 + 4 v_1 - 25 v_2 + 112 v_3 - 105 v_4$$

Dans ces calculs l'effet de l'excavation générale de la zone, antérieure à l'exécution de la fouille proprement dite n'a pas été pris en compte.

L'application de ces formules pour les valeurs mesurées des déplacements relatifs des appuis, l'extrémité inférieure de la palplanche étant prise comme référence, fournit les résultats présentés dans la Table I

Table I

Réactions des appuis en fonction de leurs déplacements relatifs

Appui	Déplacement relatif en cm	Réaction calculée ton	Réaction mesurée ton
1	- 2.5	- 3.9	6.5
2	- 5.4	14.2	15.2
3	- 9.0	8.8	8.0
4	- 12.3	9.9	6.5

Il est évident d'après ces résultats que les charges mesurées sur les étais de tête sont supérieures à celles données par le calcul. En ce qui concerne les étais plus profonds la concordance est acceptable.

Il faut donc admettre que la distribution des poussées latérales qui a servi de base au calcul n'est pas correcte, surtout pour la zone superficielle. Lors de la mise en place de la première rangée d'étais, la précharge de 12 tonnes qui a été appliquée a généré un état de butée dans le terrain.

Cependant le calcul montre que la charge de 15 tonnes mesurée dans les étais de la deuxième rangée est due uniquement aux dénivellations des appuis des étais. Il est probable par conséquent, que l'enveloppe proposée par R.B. Peck pour le calcul des charges sur les étais ne s'applique pas au cas de Mexico, du fait des déplacements exceptionnellement grands de la palplanche et des concentrations résultantes des réactions

des étaçons.

Il convient de noter, de plus, que sous l'effet des grandes déformations la résistance au cisaillement non drainé de l'argile de Mexico diminue de façon notoire, la sensibilité moyenne de cette argile étant 8. Ceci pourrait contribuer à augmenter appréciablement le coefficient  $(1 - \frac{4Su}{\gamma H})$ .

CONCLUSIONS

En conclusion, il convient, à propos des mouvements verticaux enregistrés sur le pourtour des excavations, de ne pas sous-estimer les mouvements d'expansion élastique, qui peuvent être d'importance pour le cas des argiles de faible résistance.

En ce qui concerne les poussées latérales réelles, pour les excavations à coefficient de stabilité inférieur à 5, les mesures effectuées dans les argiles de Mexico prouvent qu'elles peuvent être calculées par la méthode du coefficient de repos. Tenant compte de la présence d'une nappe phréatique superficielle et de la très faible perméabilité des argiles, la règle empirique de R.B. Peck peut, dans ce cas, être d'une application dangereuse. En effet, la poussée totale, calculée d'après cette règle, peut être inférieure à la poussée de l'eau.

Lorsqu'il s'agit d'excavations à coefficient de stabilité supérieur à 5, les déflexions subies par la palplanche avant la mise en place des étais sont très importantes pour le cas des argiles de la Ville de

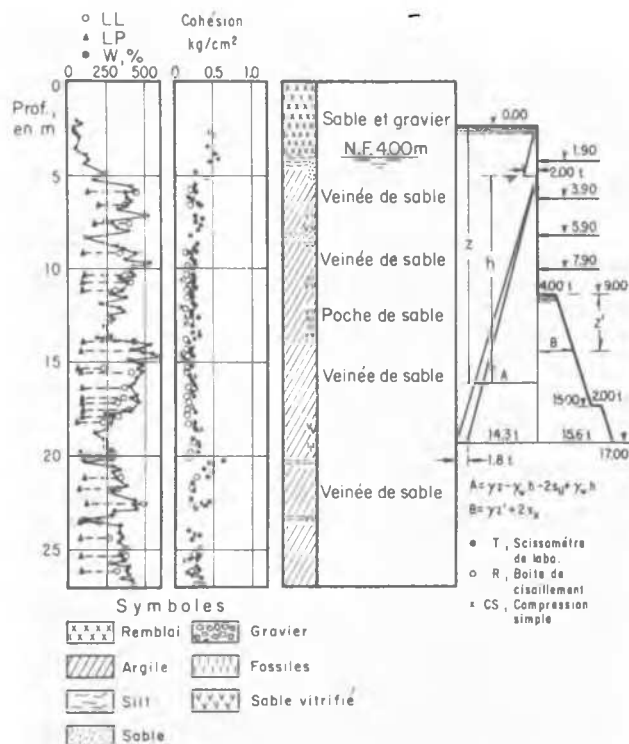

Fig 16 Coupe stratigraphique du terrain. Siphon de Morazan

Mexico. Il a été prouvé que les concentrations de charge sur les étais sont dues, tout au moins partiellement, à ces déflexions, sans qu'il soit nécessaire pour autant de supposer une variation des poussées réelles du terrain en fonction des déplacements. De plus, ces grandes déformations provoquent sans doute, une diminution notable de la résistance au cisaillement non drainé de ces argiles sensibles. Cet effet contribue à l'augmentation du coefficient de poussée. Il est souhaitable de considérer la dite réduction de résistance pour le calcul de la poussée latérale maxima d'après la règle proposée par R.B. Peck. A propos de cette règle, il faut souligner que la poussée totale qui résulte de son application, peut encore être inférieure à la poussée totale de l'eau, lorsque la nappe phréatique est superficielle.

## REFERENCES

1. Sistema de Transporte Colectivo "Mesures effectuées lors des excavations des Siphons de Dr. Olvera et Dr. Navarro", Rapport préparé par Solum, S.A., México, 1969
2. Reséndiz, D. y Zonana J. "The Short-Term Stability of open Excavations in Mexico City Clay", Volumen Carrillo. Proyecto Texcoco, 1969
3. Marsal, R.J. y Mazari, M. "El subsuelo de la Ciudad de México", Facultad de Ingeniería, UNAM., México, 1959
4. Reséndiz, D., Nieto, J. y Figueroa, J. "The elastic properties of saturated clays from field and laboratory measurements", III Panamerican Conference on Soil Mechanics and Foundation Engineering Vol. I, pp. 443-466, Caracas, 1967
5. Tschebotarioff, G.P. "Soil Mechanics, Foundations and Earth Structures", Mc Graw Hill, pp. 488, 1951
6. Skempton, A.W. y Ward, W.H. "Investigations concerning a deep cofferdam in the Thames Estuary clay at Shellhaven". Geotechnique, Vol. III, pp. 119-139, 1952
7. Rodriguez, M. y Flamand, C. "Strut loads recorded in a deep excavation in clay", Proceedings VII Int. Conf. on Soil Mech. and Found. Engineering, Vol. II, pp. 459, México, 1969.

Chairman O. MORETTO

An interesting contribution that I am sure it brings in consequence an interchange of ideas between you and Dr. Peck.

As I have made in the first part, I am going to read a little discussion on this subject.

I would like to make a few remarks on the stability of the bottom of excavations in preconsolidated clays to bring forward the difference in behaviour that may develop depending on whether preconsolidation was reached by a load that was later eroded or derives from capillary stresses due to drying. For

this purpose I will divide my statement in two parts: 1) State of stress at rest in preconsolidated soils and 2) Stability of the bottom of excavations in preconsolidated clays.

State of stress at rest in preconsolidated clays

At rest, the initial state of stress in the ground is defined by a principal stress ratio  $K_0$ , whose value depends on the geological history of the soil. This ratio is not necessarily a property of the material, but rather the product of a state of deformation and, therefore, it may be smaller, equal or larger than one, depending on the geologic process that led to the formation of the deposit.

Existing information indicates that in normally consolidated clays  $K_0 \approx 0.6$ . It has been shown (Skempton, 1961) that its value increases in clays preconsolidated by the load of deposits that were later eroded, in proportion to the ratio of preconsolidation stress and present overburden stress. Since unloading due to erosion develops under a condition of one dimensional expansion, the principal vertical stress varies without a proportional change in the horizontal principal stress, because the material cannot expand horizontally: a state of precompression remains that rises the original  $K_0$  to values that may become larger than one. On the contrary, if preconsolidation was due to partial desiccation, with the development of capillary stresses that induced an all around hydrostatic condition, during this process,  $K_0$  moves toward one, because its value becomes equal to  $K_0 = \frac{G_k}{\gamma_z + G_k}$  where  $G_k$  is the

average all around hydrostatic capillary stress at depth  $z$ . As it dries, the soil contracts and, depending on the degree of desiccation attained, it may or may not crack, as indicated in fig. 1, where the mechanism of preconsolidation by desiccation is represented.

Should the soil become saturated again, an expansion is produced that may not compensate the previous contraction, as indicated graphically in the above mentioned figure. Upon saturation, the capillary stresses disappear and the soil expands trying to recover its original state. However, since the rebound of the material is much smaller than its compressibility, it cannot recover the lateral compression undergone previously and the result is that the vertical stress practically does not change, because the thickness of the deposit varies very little but, on the contrary, the horizontal stress may likely become highly relaxed, as only part of the contractions may be recovered. In this event, the value of  $K_0$  would be not only smaller than one but, furthermore, smaller than that corresponding to the same material normally



MECHANISM OF PRECONSOLIDATION BY DESICCATION

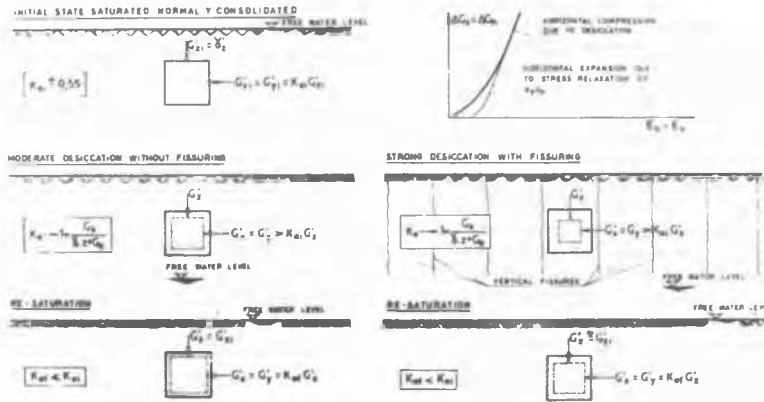

Fig. 1 - Mechanism of Preconsolidation by Desiccation

consolidated, before the desiccation process started.

Stability of the bottom of excavations in preconsolidated clays.

Since in preconsolidated clays there is no danger of a real bottom failure, the susceptibility of the bottom of an excavation in these soils depends only on the process that led to preconsolidation.

If this process yielded a value  $K_0$  larger than one, then the stress release produced by excavation may shift the state of stress nearer to the failure condition, as indicated in the Mohr diagram of the right hand side of the fig. 2.

The observations made recently in connection with the excavation required to seat the cut-off part of the core of a dam may be typical. The core is resting on soft silt and clay rock with an unconfined compressive strength of about  $15 \text{ kg/cm}^2$ , a formation that the subsoil investigation made for design purposes showed to be highly impermeable with sample recoveries that, after the few upper meters, reach one hundred per cent.

The excavation removed some 10 m of alluvium and cut a trench 5 m deep in the soft rock to enter into the intact non weathered material. In some sections, several hours after excavation had finished, the bottom started to rise and a set of fissures opened up in the surface. Grouting to seal the fissures showed them to extend to a depth exceeding 5 m below the bottom of the excavation.

When the process that led to preconsolidation is the one shown in fig 1, the stress release that derives from excavation shifts the state of stress nearer to a hydrostatic condition, as indicated in the Mohr diagram of the left hand of fig. 2, and

STRESS RELEASE DUE TO EXCAVATION IN HIGHLY PRECONSOLIDATED CLAYS

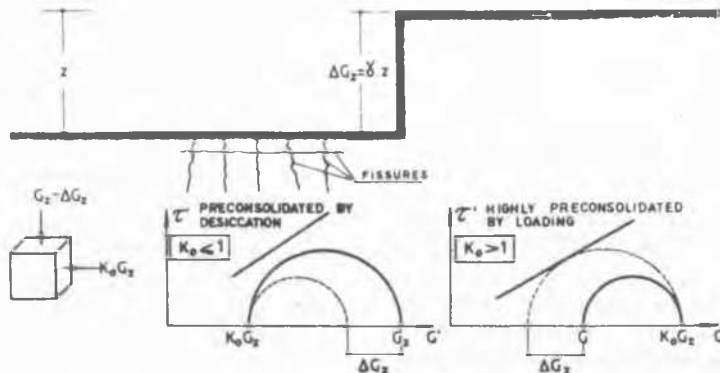

Fig. 2 - Stress release due to excavation in highly preconsolidated clays

the soil in the bottom, away from the foot of the cut, tends toward a more stable condition than it had before excavation started. This may explain the feeling of ease that some soils preconsolidated by desiccation give when observed at the bottom of excavations performed on them. Typical is the city of Buenos Aires, whose town area is underlain by very deep deposits of clay and silty soils highly preconsolidated by desiccation. Excavations over 20 m. in depth have never shown any type of distress on their bottom, where the soil appears to be easily stable. Deformations are known to be very small with a slight bottom rise of an "elastic" nature.

#### REFERENCE

Skempton A.W. (1961) "Horizontal Stresses in an Over-Consolidated Eocene Clay", Proc. 5<sup>th</sup> Internat. Conference on Soil Mechanics and Foundation Eng., Vol. II, Paris, 1961.

Chairman O. MORETTO

It is 12:30 and if you have any objections, we can follow with the session for a while and then proceed to the Pannelists discussion, which I think will be as interesting as it was in the first part. Anyway, we will reach a maximum until one o'clock. Taking your approval as granted, I give the word to the General Reporter who will lead the last part of this session. Of course I do not need to explain that the time had been tyrant with us and naturally we have no possibility to invite the audience in order to provide their oral contributions, unfortunately they must present them in writing. Dr. Peck, please.

General Reporter R. B. PECK

Gentlemen, I would like to compliment the members of the panel for producing extremely interesting information, good factual data that we can add to our storehouse of knowledge. I would also like to acknowledge the assistance I received from Mr. Harvey W. Parker in the preparation of the second part of the State-of-the-Art Report.

There have been two related objections to the General Report which perhaps I could lump together. The report must not have been as clear as it should have been or otherwise the questions would not have arisen. The rules for the trapezoidal diagram relating to strut loads, when we are talking about saturated clays with "N" values greater than about 4, should of course take into account the shear strength of the clay because, when we get to N values greater than about 4, we have passed from an elastic state to a state in which the strength of the clay is mobilized. These rules are undoubtedly applicable only when we are talking about undrained conditions and

saturated clays. We are then dealing with total stresses. Now if there happen to be some sand layers carrying hydrostatic pressure, or some fissures carrying free water in the clay, it is taken for granted that there is enough initial drainage to remove the water pressure from these free-draining elements in the soil behind the cut. But, after the excess pressure is bled out of these pervious elements, there still remains a large mass of soil whose shear strength controls the behaviour of the material behind the excavation. This soil is essentially impermeable. Hence, the pore pressures do not change significantly, or at least the water content does not change significantly during the period of construction. Therefore we should be talking only in terms of total stresses and undrained shear strength. Under these circumstances there is no theoretical reason why the earth pressure must be as great as the water pressure. It can, indeed, be less than the water pressure; that is, the water pressure that one would consider if there were no drainage from the joints or from the pervious zones. The earth pressure that we experience is a function of the shear strength of the clay, and if the shear strength is great enough, the total lateral pressure as related to the undrained shear strength of the clay can indeed be less than the hydrostatic pressure that would exist. One should always drain off this hydrostatic pressure. If one can not drain off the hydrostatic pressure in the free-draining material, then by all means the bracing has to be designed for water pressure as well as earth pressure.

Prof. Jennings on one hand has suggested that the pressures, in terms of hydrostatic equivalent fluid pressures indicated by the full trapezoids are too high. I am not quite sure how he has calculated the 36 to 72 lb/ft<sup>3</sup> density. I should point out again that the trapezoidal diagrams, being envelopes from which strut loads are computed, always refer to considerably more earth pressure than would really act on any given section. Perhaps the high values given by Prof. Jennings have their origin in failing to consider that these trapezoids are supposed to indicate envelopes for all strut loads; they are not really pressure diagrams.

However I would have some misgivings, I think, about designing the bracing for very deep cuts for a 15 pound fluid pressure. I am willing to admit the point that Prof. Jennings cuts stand up, because obviously they do, but before we can have much discussion about these numbers I would think we would have to get from Prof. Jennings some measured values of pressures or loads, and if they come out to be so low I will be the happiest man in the world to add points further to the left in the diagram.

I believe we certainly owe Prof. Moretto our thanks or pointing out that the stiffness of clays has different origins and that we certainly get different reactions depending upon whether this comes from desiccation or precompression by an external load. I

think he is absolutely correct in his interpretation of the significance with respect to bottom heave.

I think I have said enough to let my amiable colleagues find further points to disagree with.

Chairman O. MORETTO

I have immediately one point, which I think is directly connected with your diagram, that is: which is the factor of safety you have to use to calculate your struts when you use the trapezoidal diagram.

General Reporter R. B. PECK

The strut load that you calculate from the pressure diagram is the biggest load that you might ever get in a strut at a given elevation in a given cut. There will be many strut loads which are smaller than these values for struts at the given level, but there should not be any bigger ones. In fact there might not actually be one as big as calculated, but the calculated one should be the absolute maximum strut load that would develop. Now since you are also a professor in reinforced concrete and structures, I leave it to you to take it from there. If I give you a load that will not be exceeded, you may decide what structural safety factor you would like.

Chairman O. MORETTO

I probably would like a factor of safety just equal to one or just a little over one, if I want to be safer than normal.

General Reporter R. B. PECK

That is obviously the right direction.

Chairman O. MORETTO

Has any one further comments?, I think Dr. Alberro has something to say.

Panelist J. ALBERRO

Je suis bien d'accord avec le Professeur Peck pour admettre que quand il'y a des pressions dues à l'eau derrière le mur il faut les prendre en compte. Je voudrais signaler, seulement, que bien des fois ceci est perdu de vue. En conséquence, je suggère que dans les cas où l'on considère que la pression interstitielle dans l'argile est égale à la pression hydrostatique initiale (quand il s'agit des argiles très imperméables) l'on ajoute à cette pression la pression due au terme de pression effective, et qu'on redistribue ensuite cette somme sous forme de diagramme trapézoïdal.

Chairman O. MORETTO

Thank you very much. I believe Dr. Jennings has something to say.

Panelist J. E. JENNINGS

I would like to put a point to Prof. Peck. I believe that, if overall stability is concerned, one must agree this is an undrained condition, a total stress condition, because we are dealing very largely with the materials below the depth of excavation. Apart from many other reasons, the excavation can happen very quickly. But when calculating earth pressures (classical earth pressure theory is an effective earth pressure theory, I believe), one wants to differentiate between the effective pressure and the water pressure and these two must be taken in combination with each other. Now it does seem to mix up things, but this is the way to approach the real behaviour and to take account of the differences which exist when you can drain and when you cannot drain.

Chairman O. MORETTO

Any comments Dr. Peck?

General Reporter R. B. PECK

When we want to know the earth pressure for the design of a permanent structure, I think we can say we have almost no information to go on, because we actually know very little about how the state of stress becomes altered when we take out the temporary bracing and put in the permanent structure. When we have a quasi-permanent structure, as we have in a good many slurry-wall types of construction, we probably are actually interested in the earth pressure on the outside of the wall itself. At least we are as interested in these pressures as we are in the strut loads. Yet, we certainly can not get any information about the design of the walls themselves on the basis of the trapezoidal rule, I think Prof. Jennings is quite right and we must go back and try to subdivide the stresses as best we can into the pore pressures and the effective stresses. The trouble, as I see it is that we have, as yet, virtually no field data to see whether we have any reasonable way of doing this.

We are dealing with a sort of mixed problem: it is not really undrained and it is not really drained, and we do not have enough data to see whether our guesses are satisfactory. You may have noticed in the pressure diagrams that Mr. Kuesel showed concerning one of the deep cuts on BART that it is a sort of a hybrid pressure diagram. There indeed the water pressure was taken as water pressure because, as a matter of fact, drainage was not going to be permitted near this cut. The effective stresses were given an

arched distribution that looks something like the arched distribution you get from the trapezoids. This was done because it seemed the most reasonable thing to do, but I believe there is no field evidence yet that it is the right thing to do. It just looks reasonable and until we get some data this is probably all we can do. We wind up with an unsatisfactory situation with respect to that problem. I believe this is the State-of-the-Art at the present time.

Chairman O. MORETTO

Does Dr. Ward has something to say about it?

Panelist W. H. WARD

I think Prof. Peck said that outside an open excavation the settlement he found was approximately equal to the lateral deformation of the supporting structure, is that correct? Well this is not always the case; if I understood Prof. Alberro correctly he in fact was getting heaves adjacent to the excavation and presumably the lateral deformation is very small in his case. But certainly in a stiff fissured clays even if one restricts the lateral deformation of the walls to very small orders which one can do with some of these slurry trench method, one has to remember that the bottom heave has to come from somewhere on an elastic basis and it can only come from outside. Some of you might have seen some of the information I published a few years ago about the big Shell Center excavation in London which was a very wide excavation several hundred yds wide and 40 feet deep. I have no precise information about the settlement outside the area and I have no precise information about the lateral yield but I do know what was been happening at levels between 4 and 33 ft beneath and outside the excavation. The ground rose beneath the excavation; it even rose underneath the walls and it rose a little outside the walls. But I certainly know the surface settled; further outside the ground settled so that if you take the load on the main area you are certainly going to get downward movement outside, whether there is lateral yield or not, and these effects are certainly important in some cases. I might add that in the case of that particular structure which mainly unloaded the ground, the whole area is uplifting still. Even a 10, 12 storey buildings are being up lifted and being partially held down by the piles which are supposedly to be holding them up; and what is more, the area that went down outside the excavation is now swelling. In other words, the swelling is spreading outside the excavated area and this has been going on for many, many years. The total movement is going to be many inches underneath this structure.

General Reporter R. B. PECK

You are of course quite right about that

point. The observations that indicate the general equivalence of settlement and lateral movement are observations that have been made where the movements are generally fairly large and where some of the settlement is due to lateral movement and some to heave of the bottom. This in fact is the key toward one method of reducing settlements. We do have procedures, of course, for establishing stiff walls and for establishing the cross bracing before the general excavation is made, for the sole purpose of keeping the side walls in their initial position and reducing the settlement to that which is due only to what base heave remains. This is a proper procedure for reducing settlement, and you are quite right in bringing up this point. I also should have mentioned that Prof. Alberro's comments about the general rise of everything around an open cut are perfectly in order; the rise does take place, while the soil is in an elastic state, and everybody has known for a long time that they take place to a large extent in Mexico City as compared to most other spots so he has had the opportunity to observe these movements much more clearly than the rest of us.

Chairman O. MORETTO

Dr. Jennings has also something to say about these movements.

Panelist J. E. JENNINGS

We have also observed these movements upwards and outside the excavations but they are very small and they appear to be of an elastic nature, quite insignificant in comparison with the settlements which occur in the ground.

Panelist J. ALBERRO

Il est évident, je crois, que l'ampleur des mouvements élastiques est favorisée ici à Mexico, du fait que le module d'élasticité de l'argile est très bas.

Pour répondre aussi au Docteur Ward, je voudrais signaler que, par la méthode des éléments finis, le volume qui est déplacé aussi bien vers le fond de fouille, que dans la zone proche de l'excavation qui est déplacée vers le haut, se retrouve compensé quand le coefficient de poisson est de l'ordre de 0,5 par un affaissement loin de l'excavation.

C'est-à-dire que la compensation du volume s'effectue, mais s'effectue loin de l'excavation.

Chairman O. MORETTO

Is there any other comment? Well, if not I would like to put one question which I think is very important. The tie-back anchor me-

thod has become very popular. Does the panel have any experience about plastic flow of tie-back anchors in stiff clays?

Chairman O. MORETTO

Does anybody else have any more comments?  
Prof. Jennings.

Panelist J. E. JENNINGS

We have quite a bit of experience of supporting excavations with tie-back anchors. I do not like tie back anchors which are not anchored into rock or something solid. These things do yield and, in yielding they create a great deal of trouble because they usually ride up to the top of the excavation. If you make a practice of checking the stresses in the anchors at regular intervals of the order of weekly to fortnightly, and if you use anchors which are fully anchored and stressed back to at least one and a half times the anticipated pressure which you expect from any of the methods of calculation, these seem to behave well and retain their pressure.

Panelist J. E. JENNINGS

Mr. Chairman at some stage earlier, somebody talked to me about the question of supports for rock excavations and excavation of hard soils which are jointed. The behaviour is along the joints. Certainly when it comes to rock excavations, these are probably more difficult than the support of soil excavations. We know more about soils than we do about rocks, but with rocks the behaviour is predominantly along joints. One can find many cases where you have no support at all or other cases where you have to provide support which is quite equivalent to that which you would provide for a soft clay or a firm clay. One has got to make an examination of the joints in the rock. In an assessment of the pressures, I have used largely the coulumb type, but again water pressures on the joints are very important indeed.

Chairman O. MORETTO

Is there any other comment?

Panelist W. H. WARD

I have very little information to add to this question which Mr. Moretto raised. All I can say is that tie-back anchors are being promoted in the London flat Area. The only thing is that we do not know how much they creep. I suspect they are all going to creep considerably but there is no data available on this to my knowledge at the moment.

Chairman O. MORETTO

Coming to an end of this session I think we have to thank the members of the panel for a most interesting discussion on a very up-to-date problem. Thank you very much for your attention.

#### WRITTEN CONTRIBUTIONS

G. BALDOVIN (Italy)

J'aimerais bien signaler au Rapporteur Général que l'expérience acquise pendant la construction de la ligne 2 du métro de Milan a permis d'obtenir de remarquables résultats en ce qui concerne la réduction des tassements par l'avancement du bouclier.

Le terrain de Milan est un dépôt alluvionnaire incohérent constitué par du sable et gravier de compacité variable et les problèmes des tassements pour décompression a donné de grands soucis à l'administration.

On a employé un bouclier ouvert, profilé à fer à cheval, de 6 m de largeur environ. On a travaillé à une profondeur sous la route entre 6 et 12 mètres en proximité des bâtiments. On a constaté; au départ, des tassements de la route de 12-13 cm et on

#### WRITTEN CONTRIBUTIONS

a pu contrôler que ces tassements correspondaient dans une bonne mesure à la perte de terrain à l'excavation.

Une première réduction des tassements a été obtenue par injection des coulis d'argile et ciment faite à partir de la route, mais l'amélioration la plus importante a été obtenue en remplaçant les vides laissés par l'épaisseur du bouclier par du gravier calibré injecté immédiatement à l'arrière du bouclier même. Par cette solution les tassements ont été réduits à 3 cm maximum; on prévoit d'obtenir une amélioration plus poussée par l'emploi, dans les endroits les plus difficiles des injections chimiques.

Je regrette de ne pouvoir pas ici illustrer en détail les procédés adoptés: en tous cas, je désire signaler que les résultats de ces études ont été rassemblés et publiés par la Associazione Geotecnica Italiana.

L. DE COURT (Brazil)

In his remarkable report, Prof. Peck has presented some data concerning surface movements associated with tunneling operations. Construction procedures, type of soil, ground water conditions, geometry and depth of the tunnel are of great importance. For practical application of Prof. Peck's recommendations, it is fundamental to estimate the maximum settlement of the ground above the tunnel ( $\delta'_{max.}$ ) under normal conditions, accidents excluded.

It seems to us that the data presented are insufficient to permit correlations of  $\delta'_{max.}$  with all the above-mentioned factors except, perhaps, depth.

We attempted a regression analysis, assuming linear relationship between  $\delta'_{max.}$  and  $Z$ , further imposing the condition that the straight line pass through the origin: the resulting equation was  $\delta'_{max.} = 0,0025 Z$ . Repeating the same analysis but without the above imposition, we came out with the equation:  $\delta'_{max.} = 0,146 + 0,0034 (Z - 64)$ . It is felt that despite the large scatter, these equations are helpful for practically representing the data presented in the report, but strictly respecting the limits of the range within which the data have been analysed.

A. M. MUIR WOOD (England)

Heathrow Cargo Tunnel is a two lane highway tunnel linking the Central Area of Heathrow Airport, London to the new Cargo Terminal Area.

The tunnel is in London Clay beneath 3-6 m of Taplow Terrace gravels and brickearth. Economics of tunnel approach gradients dictated the advantage of setting the tunnel as high as possible. Investigations indicated that the level of the surface of the clay varied only between reasonable limits and that, as is usual beneath alluvial deposits, the weathering of the top of the London Clay was confined to a narrow band.

The tunnel design was based on residual clay strengths for stability, on strain moduli and the estimation of initial horizontal loading in the ground for determining short term and long term deformations, using an appropriate method of analysis<sup>1</sup>. The clay was highly fissured and slickensided, and while the pattern of horizontal loading in the ground,  $k_0$ , determined from samples appeared generally similar to that previously found in the locality<sup>2</sup>, the maximum horizontal loading near to the surface was taken in design as the limiting Rankine passive loading at the time of denudation of the clay surface, based on residual strengths, with the

nett addition of the superincumbent loading. The internal diameter of the tunnel is 10.3 m and the total cover is 7-8 m decreasing to about 6 m at the south end. The tunnel is lined in rings of 27 precast concrete segments, cast to fine tolerances and abutting along convex to convex joints to allow free articulation. The lining is 30 cm thick and each ring is 60 cm wide, with the ring stressed against the ground by jacks at axis level, subsequently replaced by concrete.

Analysis indicated that the excavation for the tunnel should cause some small overall uplift and that there would be a small degree of initial and long term elongation of the vertical diameter of the tunnel. In view of uncertainties in the parameters of the ground used for such calculations difficulty in assessing the loss of ground into the face of the tunnel, notwithstanding that the tunnel shield was generously equipped with platform rams and face rams, the tunnel was instrumented to record settlements, deformations and loads in the lining.

The tunnel passes beneath Runways 5 and 6, the latter only rarely used and encountered by the tunnel, before the former. Since the principal concern was the measure of movement caused to a runway over the tunnel, a ring of lining underneath Runway 6 was selected for study. The scheme comprised:-

- a) Surface levelling points tranverse to the tunnel line, immediately above the trial ring, were recorded for movement vertically and horizontally.
- b) On the tunnel centre line, three 5 cm diameter holes were drilled in which probes were inserted to measure vertical movement at the bottom of the hole relative to the surface. The probes were anchored 50cm below the tunnel invert, 90cm above the crown and 75cm below the top of the clay respectively.
- c) 15cm diameter rigid PVC tube lined boreholes sunk 60cm clear of and to each side of the tunnel and horizontal movement measured by means of a plumb bob constrained by a pantograph mechanism to travel centrally, supported by wire from a drum and head - gear system for measuring depth and inclination.
- d) Deformation of the tunnel lining was measured by Invar tace with a specially designed portable straining head, with provision made for measurements to continue during the life of the tunnel.
- e) Loads in the ring were measured by pairs of photoelastic load cells mounted at crown, invert and at axis level at each side of the tunnel. The type of load cell was selected for

its ruggedness, long term reliability and because the stiffness could be made comparable to that of the replaced concrete.

The results of the instrumentation (figure 1) indicated that ground movement on the tunnel centre line, a measurement that was repeated at intervals along the full length of tunnel cross - hatched in figure 1, amounted to about 11mm in aggregate and varied little from a pattern which indicated about half the total being developed immediately above the shield cutting edge. Immediately above the shield a considerable reversal of movement occurred during passage of the shield and the full extent of about 14mm settlement was attained at the rear of the shield. At the invert, the clay rose by about 3mm before the cutting edge of the shield prevented further measurement. Generally the pattern of movement occurred radially into the tunnel with the overall magnitude of loss of ground indicating an axial movement of the tunnel face of about 15mm. (figure 2).

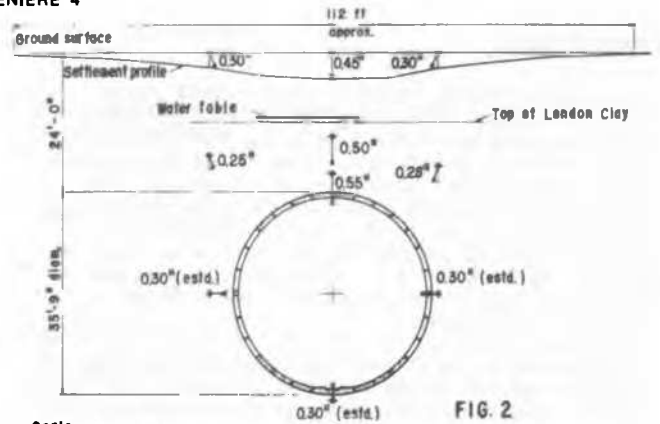

FIG. 2 Ground Movement Around Tunnel Heathrow Airport London Cargo Tunnel.

The load cells indicated (figure 3) that, while initially the load at invert was the same as the load at one side of the axis while the load at the other side of the axis was equal to the load at the crown with a difference of about 15%, after about 600 days, the difference bet

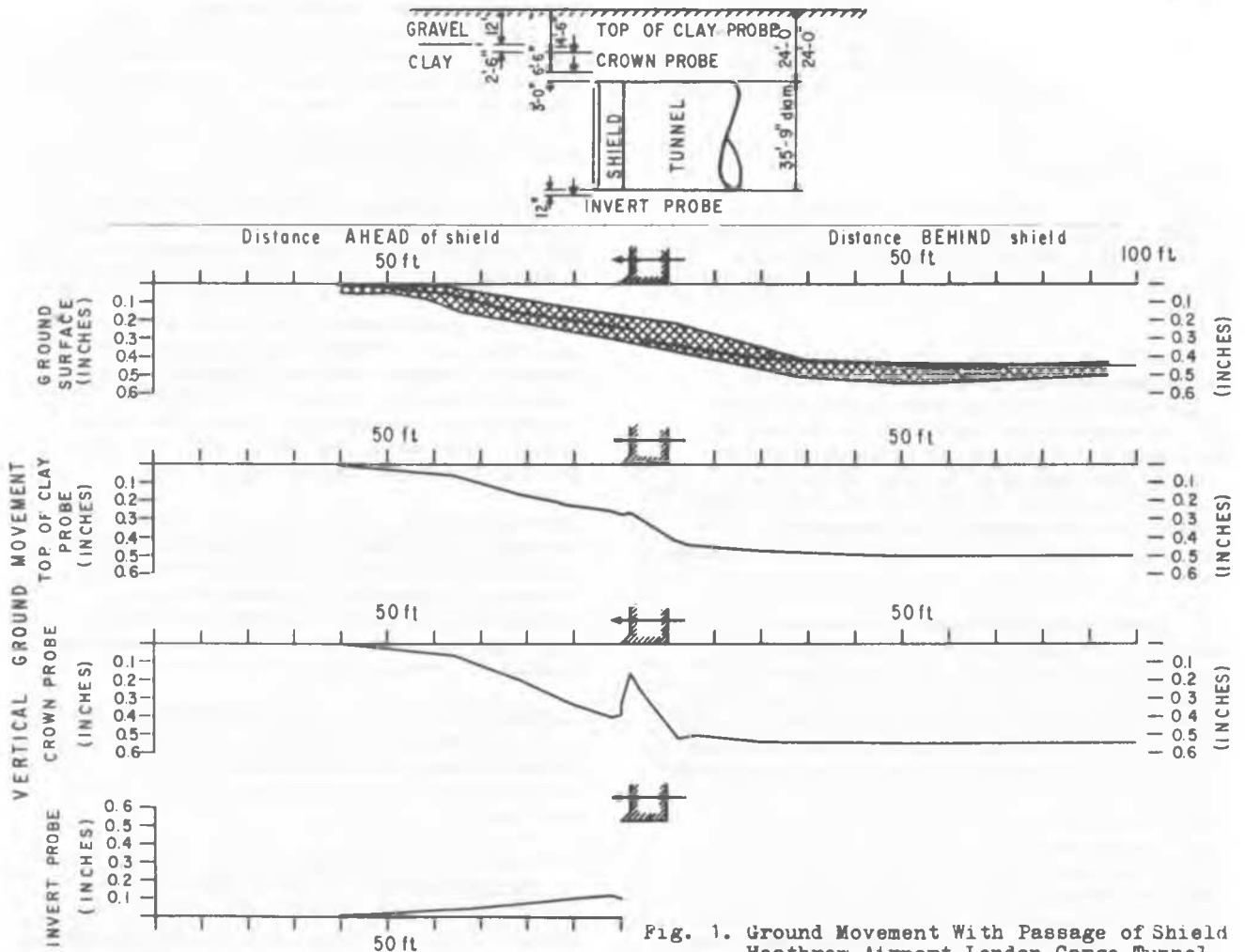

Fig. 1. Ground Movement With Passage of Shield Heathrow Airport London Cargo Tunnel.

ween the invert load and the crown load was about 30%, with the crown load about 15% greater than the weight of overburden at this level. It is therefore apparent that considerable shear forces exist between the ground and the extrados of the lining.

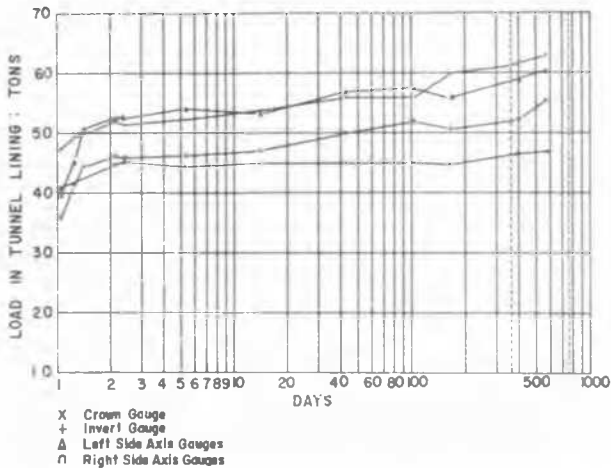

Fig. 3. Ring No 111: Load Cell Measurement Heathrow Airport London Cargo Tunnel.

The records of tunnel deformation (figure 4) indicate, contrary to expectation, some small increase in horizontal diameter amounting to an average, for six measuring points, of about 1.5mm in the first year. This result merits comparison with the relatively deep level experimental tunnels for the Victoria Line.<sup>3</sup> This phenomenon does not appear previously to have been explained in terms fully corresponding to observation at the time of construction. It is suggested that at Heathrow the principal cause may lie in the relatively higher horizontal permeability of the clay leading to differential rates of consolidation around the tunnel. If this is correct the trend should be reversed in due course.

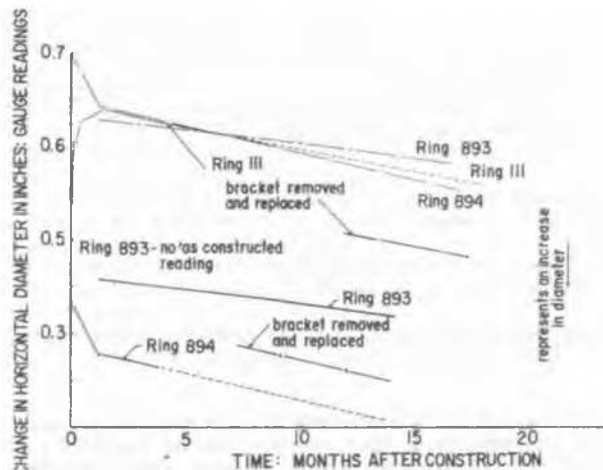

Fig. 4. Deformation of Lining with Time Heathrow Airport London Cargo Tunnel.

References

1. Morgan, H.D. A contribution to the analysis of stress in a circular tunnel. *Geotechnique*, Vol 11 No.1 (March 1961) pp 37 - 46.
2. Bishop, A.W. Undisturbed samples of London Clay from the Ashford Common shaft: strength-effective stress relationships. *Geotechnique*, Vol 15 No.1 (March 1965) pp 1 - 31.
3. Ward, W.H. & Thomas, H.S.H. The development of earth loading and deformation in tunnel linings in London Clay. *Proc. 6th Int. Conf. Soil Mech. and Found. Eng.* Vol 2 pp 432 - 436 (1965).

NEFTALI RODRIGUEZ CUEVAS (Mexico)

On the state-of-the-art report<sup>(1)</sup> presented to the Conference, there are few theoretical aspects on which author would comment. Throughout the general report, and explicitly mentioned at the conclusions of the first part of the paper, Peck stressed the influence of inelastic behavior around a tunnel, and contemplates procedures to take into consideration the inelastic behavior of soil, through stress-strain time relationships, to improve the general understanding of tunneling, as well as to improve construction procedures.

Nevertheless, the general report supports the use of an error curve, as the only available solution to explain the behavior, without further comments on the possible approach to understand the behavior of the soil surrounding a tunnel. Searching through literature, the error curve was first mentioned by Litvinszyn<sup>(2)</sup>, as the result of a stochastic approach to the problem; it is applicable to fractured and granular material, assuming elements of ground to be of the same size, and of rigid characteristics. A mathematical operator was derived, and the expression to define subsidence at the surface, comes out to be the error curve.

It seems difficult to author to understand how the inelastic behavior of soil can be taken into consideration following that approach, and how stress-strain time constitutive laws can be used. So far there is another stochastic approach<sup>(3)</sup>, of limited use, that can take into consideration time effects; the results obtained justify the use of the viscoelastic behavior of a continuum, to represent the stochastic process.

Therefore, it would be possible to study a visco-elastic continuum around an opening, to represent the stochastic processes involved; this possibility was explored by author<sup>(4)</sup>, using as constitutive laws an elastic volumetric component, and a deviatoric component expressed by differential operators, representing a Maxwell-Kelvin unit.



A continuum with a circular excavation of radius  $r_0$ , located at a depth  $H$  below the surface of the medium was studied, to define the displacement field around the opening, using stress-strain-time constitutive laws above mentioned. A viscoelastic solution was obtained, enabling the possibility to define all the displacements, the stresses, and the strains inside the continuum, in order to understand the behavior of soil around a tunnel.

Subsidence at the surface was computed, obtaining a curve similar to that proposed by Peck, although a little bit flatter, with characteristics dependent on material parameters, as well as on geometric features of the opening. Position of inflection points is a function of length  $\sqrt{H^2 - r_0^2}$  being this length a characteristic parameter of the problem. It was also found that shape of the subsidence curve, depends on time, indicating an increase in subsidence as time elapses.

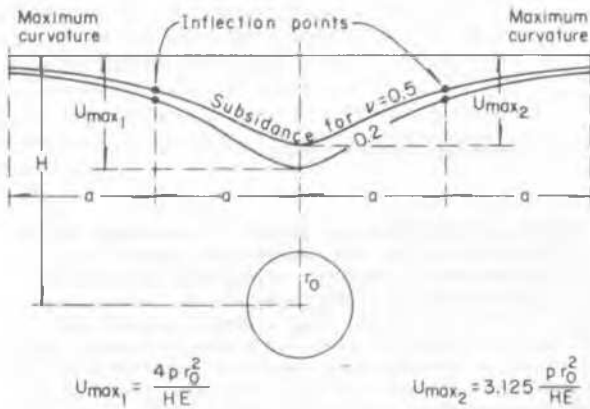

Fig 1 Vertical displacements at the surface, due to the opening

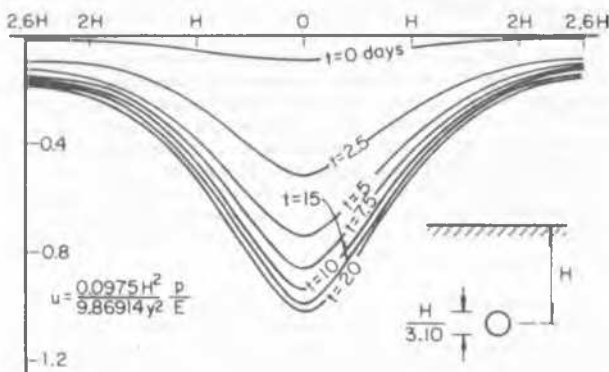

Fig 2 Surface subsidence due to an opening, with  $H/2r_0 = 3.10$

Experience gained during the construction of two tunnels at Mexico City, using the shield technique, on sandy soils laying over a deep clay stratum, indicated vertical displacements at the surface, similar to those defined by the viscoelastic solution, and an increase in displacements as time elapsed.

Measured field data, as well as theoretical results, indicated vertical displacements ten to twelve times those measured instantaneously at a given section, three months after the shield had passed through that section. Therefore, it seems to author that values, reported by Peck on tables III and IV, should be taken as instantaneous values, due to their magnitude.

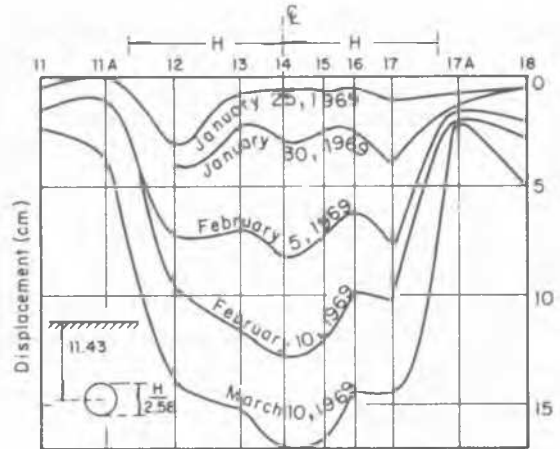

Fig 3 Vertical displacements of the surface of the ground, over the siphon, for  $H/r_0 = 2.58$

Another fact can be obtained from the viscoelastic solution: the existence of horizontal displacements at the surface and inside the continuum. At the surface, the displacements are represented by vectors passing through the center of the opening, with magnitudes dependent on time, as well as on material characteristic, and geometric relationships.

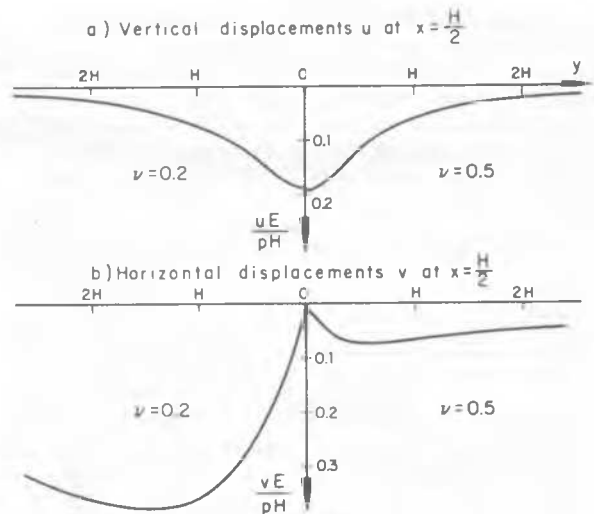

Fig 4 Vertical and horizontal displacements at  $x = H/2$ , due to the opening

Inside the continuum, and around the opening, vertical and horizontal displacements can be computed for different instants, giving a clear idea of the behavior. These theoretical findings had been substantiated by field data, using vertical inclinometers

nearby tunnel locations, showing a similar response as that given by theoretical results.

The viscoelastic solution can also give a whole picture of stress, strain and displacement distribution inside the continuum. Once the tunnel location has been defined computations following a program developed for a digital computer can be performed, in order to define stress and strain fields; a clear dependence, on the ratio  $H/r_0$ , has been found, as well as on material characteristics.

Existence of compressive stresses at the surface, on a central zone extending a distance  $\sqrt{H^2 - r_0^2}$ , at both sides of the point at the surface over the center of the tunnel, was detected; tensile stresses developed at the rest of the surface, being their magnitude dependent on the ratio  $H/r_0$ , as well as on the volumetric weight of the continuum. Tensile stresses at the surface, might be responsible for damages and fractures, when deep tunneling is performed.

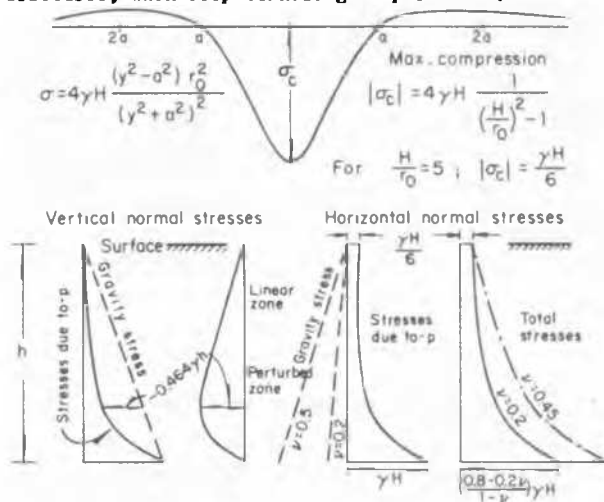

Fig 5 Distribution of normal stresses parallel to the x axis, and to the y axis, inside the medium

Finally, the viscoelastic solution could be used to define pressure distribution on linings of tunnels, for different stiffnesses of the lining, being an interaction problem that could be solved by computers, indicating a dependence on time; this possibility has not been contemplated so far, by any stochastic solution already known.

REFERENCES:

1. Peck, R. B.: "Deep excavations and tunneling in soft ground". Seven International Conference of Soil Mechanics and Foundation Engineering. Mexico, 1969. p. 225 to 281.
2. Litviniszyn, J.: "Displacements in Loess Bodies as Stochastic Processes". Bull. de L'Academie Polonaise des Sciences, 1955, III 4.
3. Gabrielsen, B.L.: "Stochastic models for viscoelastic materials". Rilem, "Materials and Structures". July-August, 1968, p. 319 to 326.
4. Rodriguez N. "A simplified model for tunneling and linings". Private report presented to SCT. 1969.

E. B. SOUTO SILVEIRA and N. GAIOTO (Brazil)

As was mentioned by Peck in his remarkable State-of-the-Arts Report, presented to this

Conference, an important requirement for a satisfactory tunnel is that its construction should not damage excessively the adjacent and overlying buildings. For the design of the São Paulo subway, presently under construction, some of his records and criteria on settlements, caused by shield construction were interpreted and applied by Promon Engenharia, in order to help specify the special precautions, treatments and underpinnings required by the buildings.

It is easy to evaluate the numerous problems connected with interference on traffic, existing utilities, foundations and even underground floors, that had to be considered for the construction of a subway in the center of a city of seven million inhabitants, near and under its hundreds of skyscrapers, and through its most important bank and business streets.

The 1.2 km of the first line of the subway, that is being designed by Promon Engenharia, (\*) is at the most central point of the town, with two large stations, and with the two tunnels following beneath a 16 m wide banking street, surrounded by skyscrapers, then going below the oldest historical quarter of the 400 years-old town, and then below several blocks of high and also important buildings (Fig. 1).

The soil profile at the site can be broadly described as a remarkably heterogeneous soil (Fig. 1), with interconnected and erratic layers and lenses of clayey sands (loose to dense) and sandy clays (soft to stiff), underlain in part of the area by a medium to coarse sand. Some of the clayey layers are preconsolidated, but there are numerous and erratic lenses of soft clays, and also of loose sands. Water level varies from 3 to 10 meters depth. Two tunnels will be constructed at depths up to 25 meters, as also indicated in Fig. 1.

One of the problems that had to be solved was the establishment of rational criteria to serve as guides for the decision on special precautions, treatments and underpinning buildings. Besides other criteria already in use, Peck's records and criteria, presented at this Conference, were interpreted and used for this important decision.

Peck's Fig. 9 of  $\gamma/2R$  vs.  $i/R$  presents the average bands for the different types of soils, based on the data recorded in Table VI. The specific curves representing the same data were used for the present design study.

In order to estimate the settlements, however, the records given in his table VI had to be analysed and interpreted. It may be observed that the most important design parameter should be, for a start, the estimate of the probable maximum crown settlement, depending principally on the depth and dimensions of the tunnel and the nature of the soil. Since in this point no indications were furnished, the data were investigated in search for some

(\*) Promon's Soil Mechanics Consultant is Prof. Victor F. B. de Mello; Promon's Consultant on shield design is "Sir William Halcrow and Partners", London.

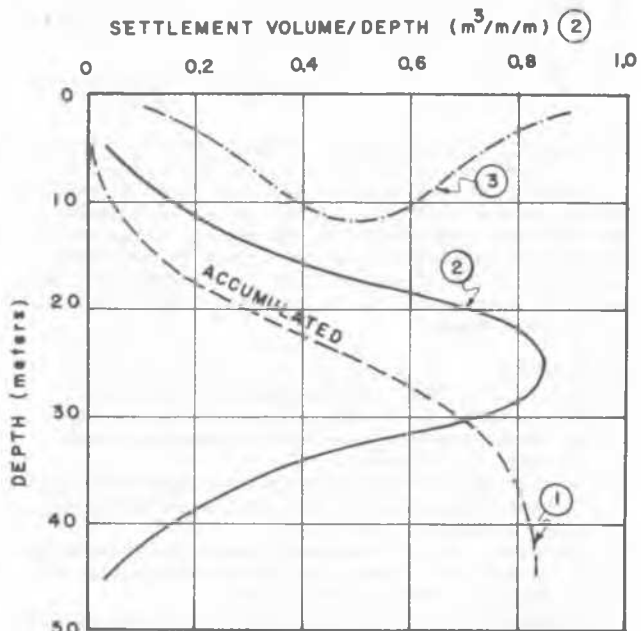
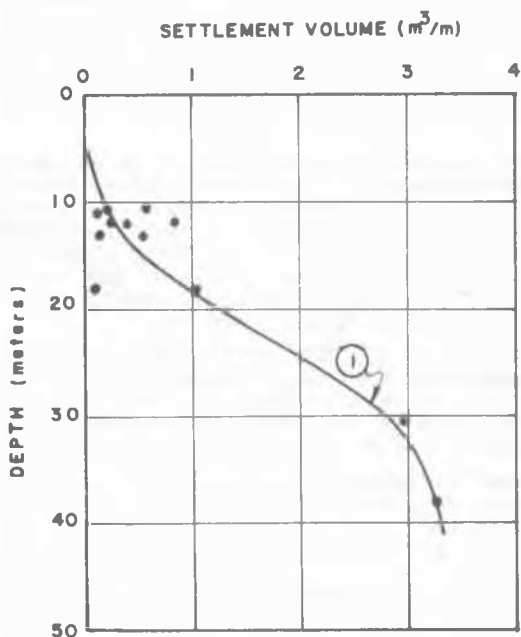
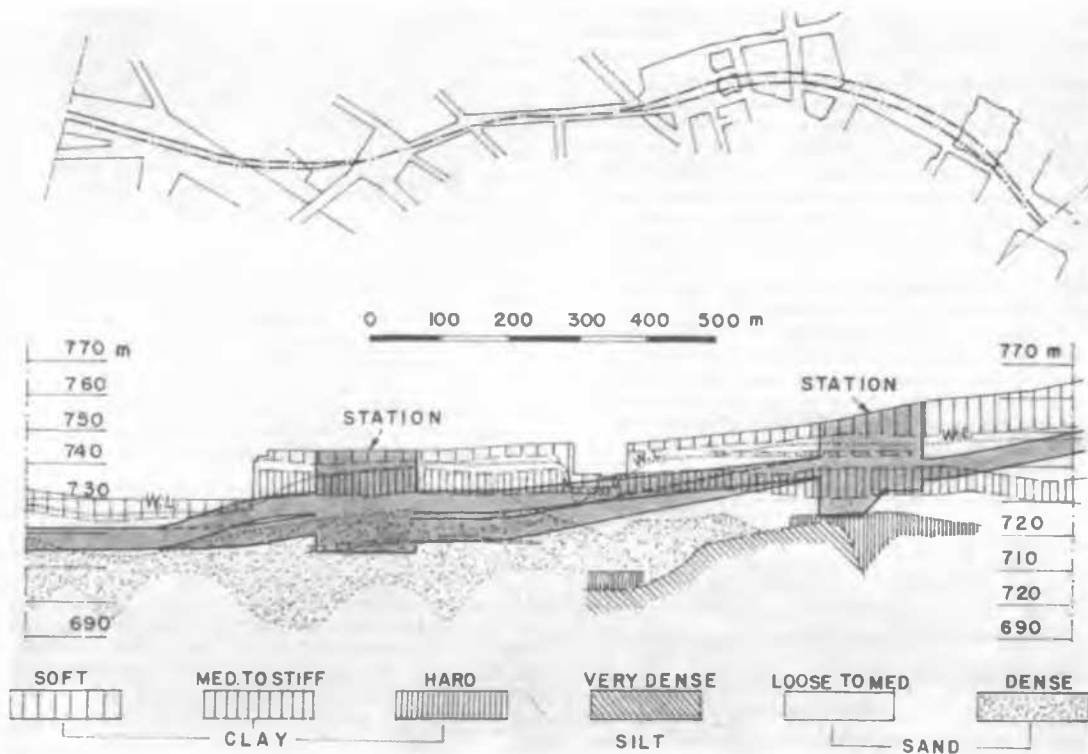

- (1) - Curve (1) of fig. 2, no scale
- (3) - Lateral distribution of settlements, no scale, according to Peck's fig. 8.

Fig. 3 - Interpretation of settlements above tunnels.

Fig. 2 - Best fitting curve of settlement volume vs. depth

empirical correlation. Obviously, after estimating the crown settlement, the settlement distribution may be derived from the curves of Fig. 9.

Fig. 2 shows the best fitting curve of  $V_s$  (volume of settlement) vs. depth, and Fig. 3 shows its logical interpretation, i.e., the best fitting error curve of the unit  $V_s$  along depth, Fig. 2 being its accumulated curve. After many trials at more complete correlations, it was concluded that the data did not permit insertion of the possible influences of tunnel diameter and type of soil, the present correlation being therefore simply one connected with the depth as a single intervening parameter.

Interpreting the curve established one would conclude that: i) the greatest settlement occurs at about 25 meters depth; ii) at small depths, up to approximately 10 meters, the settlement is almost negligible; iii) below approximately 40 meters, any increase in depth of the shield will have an almost negligible effect on the settlements. Of course, these conclusions, as all the others connected with the subject, should be revised through a thorough statistical analysis of the shape and equation of the best fitting curves (for the present assumed as an error curve), which will only be possible with more data than those made available at present.

With the two mentioned graphs, the lines of equal settlement along the two tunnels were calculated, for the different positions and depths of the tunnels, and different soils. The results served as one of the bases for the decision of the special treatments to be conducted, and of the underpinnings of the buildings, depending upon their structural material, shape and foundations. An intensive program of measurements of settlements of several points of the buildings is programmed, so that these criteria may be checked and revised. These same criteria were also helpful for programming the field observations to be carried out.

#### C. VINEL (Belgique)

Les éléments qui suivent complètent les informations présentées par C. VINEL et A. HERMAN dans le rapport préliminaire sous le titre "Tunnel dans le sable de Bruxelles par la méthode du bouclier".

Le terrain au droit du tunnel comprend de haut en bas :

- une couche de remblai d'épaisseur variant de 2 à 6 m.;
- une couche d'environ 17 m. de sable fin Bruxellien, décalcifié dans sa partie supérieure;
- une couche importante de sable argileux Yprésien.

La nappe phréatique se situe à l'intersection de l'Yprésien et du Bruxellien.

Le bouclier traverse toutes ces couches.

Son diamètre est de 10 m. et la couverture de terre passe de 16 M. à 6 M.

Les tassements produits sont dus à deux causes principales : la faible tenue du front d'attaque et la difficulté de remplir le vide annulaire de 18 cm à l'arrière du bouclier.

Pour ausculter le terrain avant et après passage du bouclier, nous avons employé divers appareils :

- le pénétromètre;
- des repères de tassement en profondeur consistant en un lestage, par une masse de 200 kg, des tiges placées au pénétromètre;
- un inclinomètre de la Slope Indicator Cy;
- des cellules Glöttzl, placées à 1 m. autour du futur tunnel, verticalement, horizontalement et à 45°;
- des géocells Ménard, placées au dessus et au niveau du diamètre horizontal du bouclier;
- des cellules Geonor, scellées dans les voussoirs en béton ;
- des extensomètres Geonor dans les armatures des voussoirs et dans les tirants;
- des piézomètres Warlam.

Il y a eu deux zones d'essais, l'une dans l'Yprésien, l'autre dans le Bruxellien. Tous les appareils cités ci-avant y sont représentés en nombre suffisant pour permettre une interprétation statistique des résultats.

Voici les résultats obtenus :

- 1) les tassements produits à la surface et en profondeur montrent un affaissement centré sur l'axe du tunnel. On a pu en tirer la zone d'influence du bouclier. On voit nettement que le terrain se soulève à l'avant du bouclier, puis qu'il s'affaisse en laissant une dépression permanente au droit de l'axe du tunnel; dans ce terrain qui contient des bancs gréseux horizontaux, on constate que l'amplitude des tassements n'est pas fonction de la profondeur.
- 2) l'inclinomètre met en évidence les phénomènes suivants : le sol commence par être refoulé à l'approche du bouclier; après le passage de ce dernier le terrain supérieur reflue vers les zones décomprimées; à la base il y a glissement vers l'arrière, facilitée par la présence de la nappe phréatique.
- 3) les cellules Glöttzl montrent l'augmentation de pression initiale qui correspond à l'approche du bouclier. Une chute brutale de pression se constate après passage de ce dernier. La remontée de pression ultérieure correspond aux injections et à la remise en place naturelle du terrain.
- 4) les cellules Ménard, comme les cellules Glöttzl, montrent que c'est la cellule placée au dessus du tunnel qui atteint la première son maximum; sa pression est,

en effet, limitée par le soulèvement des terres en surface.

- 5) les extensomètres enregistrent nettement les flexions de l'anneau du tunnel dans son plan et la flexion du plan lui-même sous l'effet des vérins d'avancement du bouclier. On y remarque que les tensions maximales restent acceptables et que la tension de stabilisation correspond aux valeurs calculées.
- 6) la déformée du tunnel, mesurée topographiquement, fait apparaître une asymétrie. Celle-ci ne se justifie pas a priori dans la partie rectiligne du tunnel, le terrain y étant composé de couches horizontales homogènes.

Par ailleurs, les diagrammes montrent l'efficacité des tirants métalliques qui maintiennent l'anneau en béton, malgré l'absence de butée latérale dans ce terrain très compressible.

La présente communication devait être illustrée en séance par une série de diapositives. Comme celles-ci n'ont pu être projetées, l'auteur prie le lecteur intéressé de lui réclamer les diagrammes à l'adresse suivante :

Bureau d'Etudes ELECTROBEL,  
1, place du Trône  
Bruxelles 1  
B E L G I Q U E.

to the excavation process were measured by means of a Wilson type Slope Indicator, recording daily readings with an approximation of 0.0009 radians.

The soil profile is similar in both cuts: superficially there is a layer formed by a sandy silt having a thickness of about 4.00 m. Underlying this layer there exists a soft clay deposit with high compressibility down to a depth of about 30.00 m. Figures 1 and 2 show the soil profiles at each of the cut sites; for simplicity sake number 1 has been associated to the 5.30 m wide siphon and number 2 to the 3.50 m wide siphon. These figures also show the values of the natural water content ( $w$ ), plasticity limits, natural unit weight ( $\gamma$ ) and shearing strength as determined by unconfined compression tests ( $q_u/2$ ), direct shear tests ( $S_f$ ) and undrained triaxial tests ( $c$ ).

Figures 3 and 4 show graphically the values of the

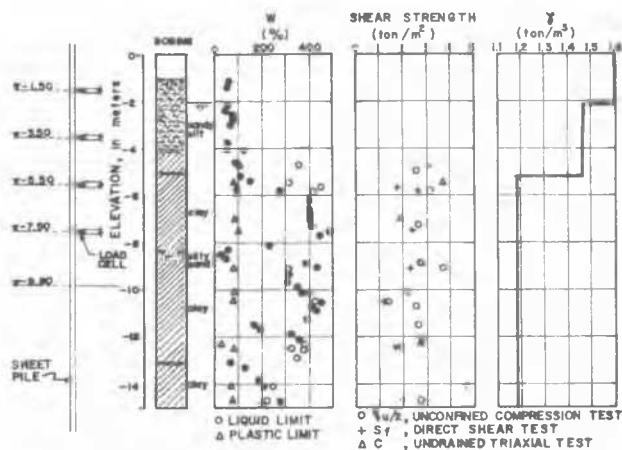

Fig 1. Cross section, soil profile and soil properties at the site of the cut for siphon No. 1.

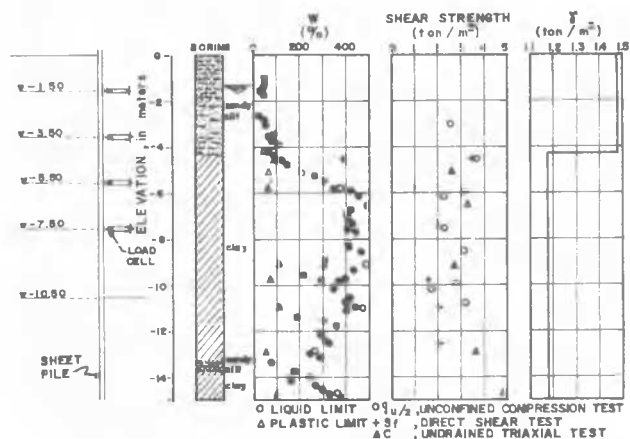

Fig 2. Cross section, soil profile and soil properties at the site of the cut for siphon No. 2.

J. M. RODRIGUEZ and R. LOPEZ PEREZ (Mexico)

The experiences herein briefly described are referred to cuts which have been excavated for the construction of two siphons required at the crossings of sewage collectors and the Mexico City subway.

Both cuts were supported longitudinally by a steel sheet piling, hammered to a depth of about 18.00m; and by four levels of struts. One of the cuts, 5.30 m in width and 35.00 m in length reached a maximum depth of 9.80 m; the other, 3.50 m width and 32.50 m in length reached a maximum depth of 10.50 m.

The strut loads were measured daily, by means of Freyssinet jacks assembled in closed circuit with a 140 kg/cm<sup>2</sup> capacity manometer; the accuracy of the jacks is approximately 1.0 ton.

The horizontal deformations of the soil associated

apparent total earth pressure and of horizontal soil deformations with respect to depth for several excavation stages at each siphon. The earth pressure was computed from the measured strut loads. To simplify the presentation and interpretation of results, a sequence of numbers in arithmetic progression was assigned to the days elapsed from the date of the initial measurement of the Slope Indicator, labeled 1st day. These figures show four types of envelopes of the computed earth pressure at different excavation stages. The solid line represents the measured values and the other three lines the theoretical ones among which the broken line with long dashes was obtained from Peck (1967)<sup>1</sup> criterion considering a reduction factor "m" of 0.4, which is the value recommended for the case of México City, provided the stability number (N) be greater than 4 in siphons Nos. 1 and 2, the N value resulted 4.5 and 5.3 respectively, the curve with a dash and two dots is the one proposed by Brinch Hansen (1953)<sup>2</sup> after reducing the undrained shear strength by the specified safety factor of 1.5. It is worth mentioning that the rotation of the sheet piling did not take place around the first strut level as assumed by Brinch Hansen, but instead it occurred around a point located between the second and the third strut level, which confirms the statement of Rodríguez and Flamand (1969), referring to the fact that the second strut level becomes in general the most heavily loaded.

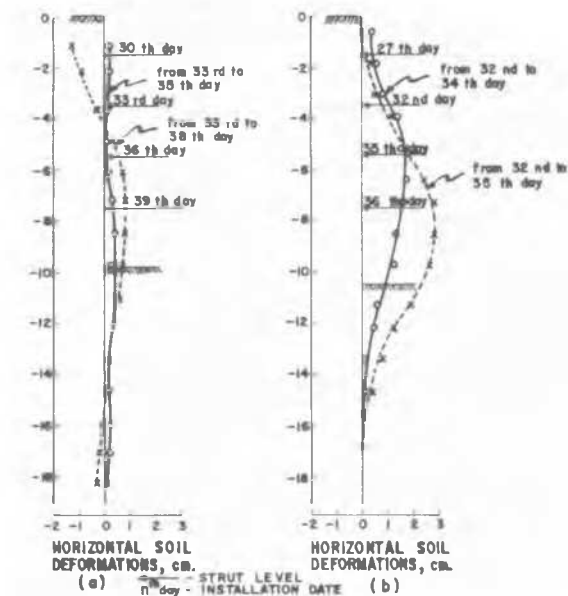

Fig 5. Variation of horizontal soil deformations for different installation dates: a) at siphon No. 1; b) at siphon No. 2.

In Figure 5 the solid line shows the increments in horizontal soil deformation with depth occurred during the time elapsed from the installation of the second strut level to immediately before the placing of the third strut level and the dotted line shows the

deformation increments up to a few hours before installing the fourth strut level; it can be seen how both curves intercept each other at approximately Elev. -4.50 m in siphon No. 1 and at -5.50 m in siphon No. 2.

The average and maximum ratios between horizontal ( $\bar{\sigma}_H$ ) and vertical ( $\bar{\sigma}_V$ ) total pressures observed at the excavation stages being analyzed were computed and the results are shown in Figures 6-a and 6-b with respect to the ratio between the depth of the cut H and the critical depth  $H_{crit}$  ( $4c/\bar{\sigma}$ ). A linear relationship of such factors has been considered with out making an important mistake since the range of variation of the ratio  $\bar{\sigma}_H/\bar{\sigma}_V$  is very narrow; the fact that such relationship is approximately linear implies that the reduction factor "m" varies in the opposite way to the one proposed by Peck when it is correlated to the stability factor "N" (Figure 6-c).

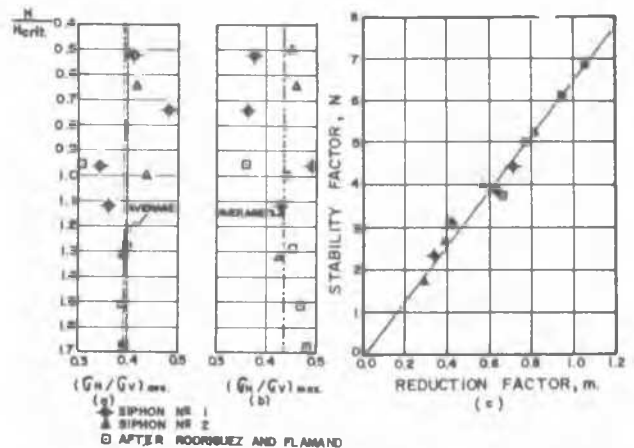

Fig 6. a) Relationship between the ratio  $H/H_{crit}$  and the ratio  $(\bar{\sigma}_H/\bar{\sigma}_V)_{ave}$ .  
 b) Relationship between the ratio  $H/H_{crit}$  and the ratio  $(\bar{\sigma}_H/\bar{\sigma}_V)_{max}$ .  
 c) Reduction factor "m" versus stability factor "N".

From the above mentioned discussion, it was concluded that an earth pressure envelope, similar to the one proposed by Peck (1967) in which the horizontal pressure is defined by the total vertical pressure ( $\bar{\sigma}_V$ ) and by the average ratio  $\bar{\sigma}_H/\bar{\sigma}_V$  obtained from Figure 6-a, provides acceptable results which only differ in  $\pm 20\%$  from the measured ones, with the only exception of those corresponding to the second strut level of the siphon reported by Rodríguez and Flamand (1969). This envelope is shown in Figures 3 and 4 by the broken line with short dashes.

ACKNOWLEDGEMENTS.

Thanks are due to Messrs. Rogelio López F. and Salvador Peredo for their valuable assistance.

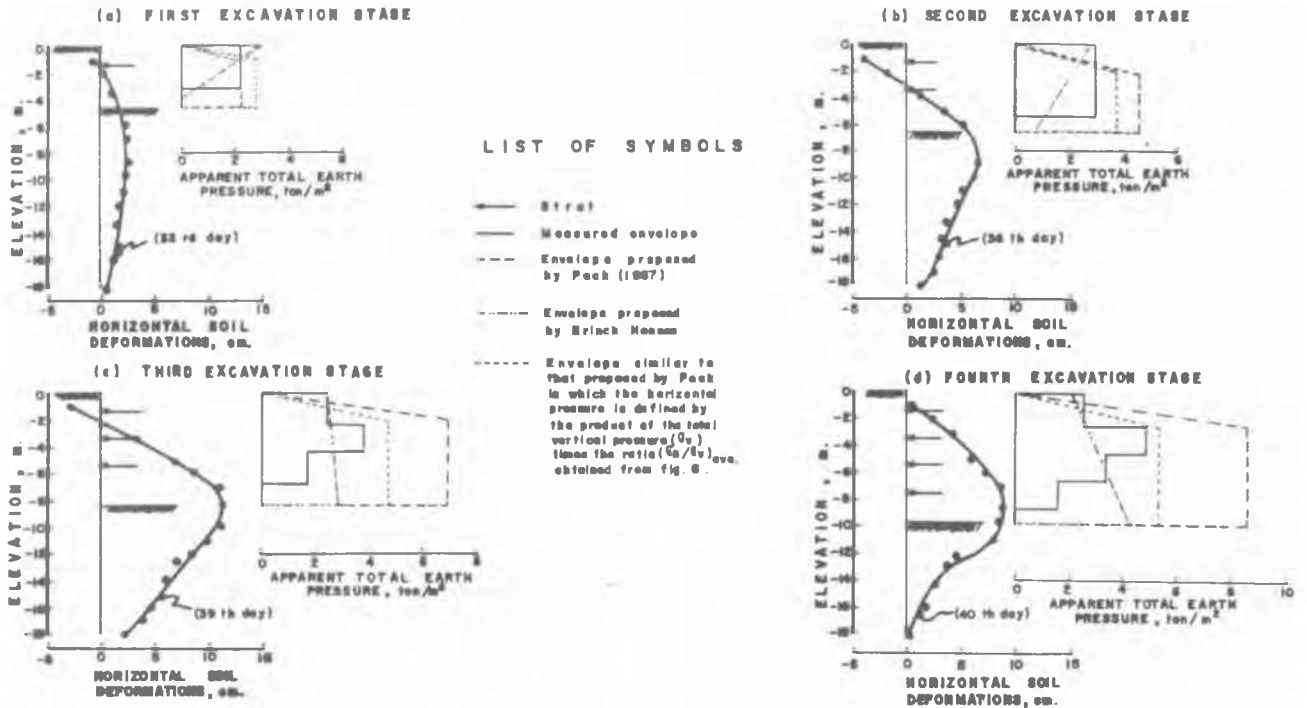

Fig 3. Variation of apparent earth pressure and of horizontal soil deformations for different excavation stages for siphon No. 1.

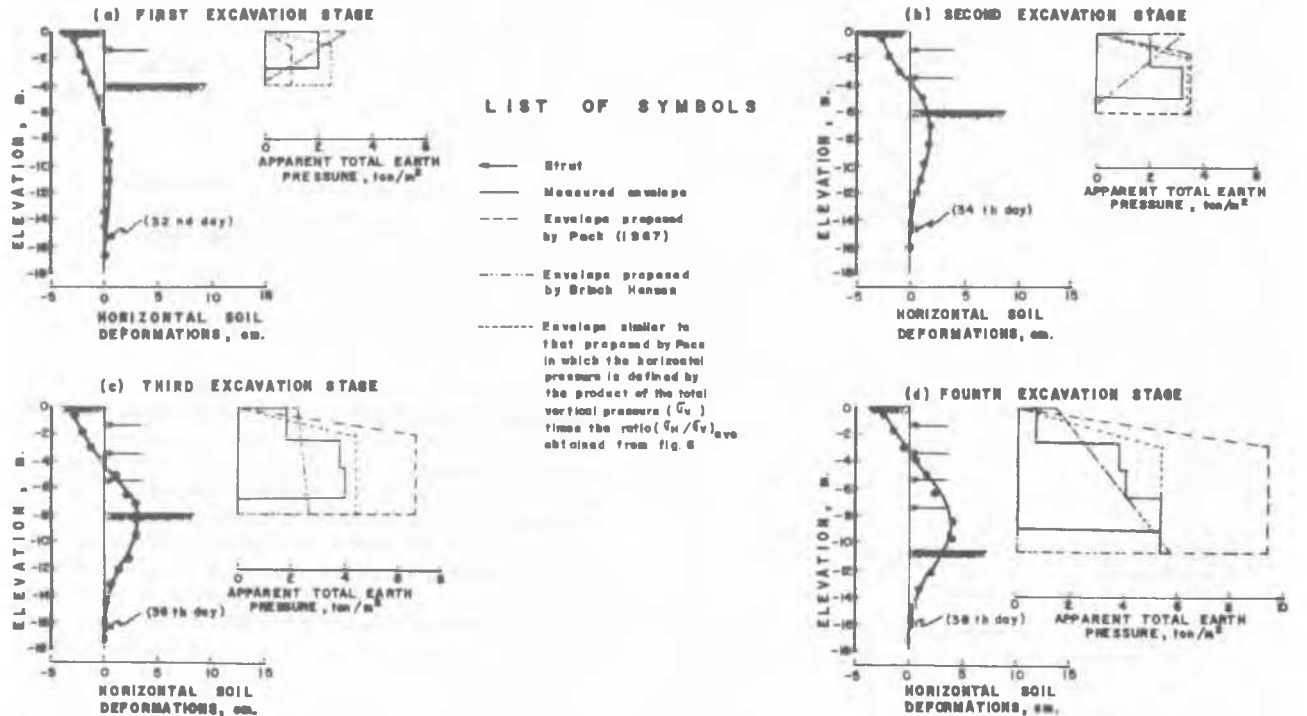

Fig 4. Variation of apparent earth pressure and of horizontal soil deformations for different excavation stages for siphon No. 2.

REFERENCES.

- 1.- TERZAGHI, K. and PECK, R. B. (1967). "Lateral Supports in Open Cuts". Soil Mechanics in Engineering Practice. John Wiley and Sons, Inc. U.S.A. pp. 403 - 413.
- 2.- BRINCH HANSEN, J. (1953). "Practical Earth Pressure Problems. Earth Pressure Calculation". The Danish Technical Press. Denmark, pp. 220 - 222.
- 3.- RODRIGUEZ and FLAMAND (1969). "Strut Loads Recorded in a Deep Excavation in Clay". Proceedings of the Seventh International Conference on Soil Mechanics and Foundation Engineering, Vol. 2. pp. 459 - 467.

J. M. RODRIGUEZ and C. A. MELGOZA (Mexico)

The theoretical analysis of this phenomenon was performed by Juárez Badillo and Rico Rodríguez (1967)<sup>1</sup> and it is explained in a simple way as follows: let us consider a clayey material having a horizontal surface with ground water level at the surface. A soil with these characteristics will have the very well known distribution of total, effective and pore pressures.

If it is assumed that a very rapid excavation of infinite length is made to a depth "h", then total pressure will be decreased in the full depth by a factor ( $\gamma h$ ), where  $\gamma$  is the unit weight of the soil. Due to the fact that a clay is being considered, the effective pressure before and immediately after the excavation will remain the same; then to maintain the same ratio among total, effective and pore pressures it will be necessary that the later decreases in value by the same amount h which will create tensions in the water below the bottom of the excavation and the null pore pressure will be located at the certain depth under such bottom. As a result of having performed a rapid excavation of infinite length, it has been possible to lower the pore pressure in the soil located under the bottom of the excavation.

Actually there are no excavations of infinite length and the total pressure will only be altered down to a certain depth, below which the total pressure existing prior to the excavation will remain the same.

Under the above mentioned conditions the water will flow towards the bottom of the excavation inducing the ground water level to return to its initial position after a certain time has elapsed, unless the flow of water is restricted by pumping or by sheet piling.

In order to study this phenomenon piezometric level measurements were recorded at the exca-

vations made to construct a siphon at two crossings of sewage collectors and the Mexico City subway.

The dimensions of the excavation for siphon No. 1 are 35 m in length and 5.30 m in width with a maximum depth of 9.30 m and those corresponding to siphon No. 2 are 32 and 3.50 m respectively with a maximum depth of 10.50 m. In both excavations a sheet piling was driven to a depth 8.0 m below the bottom thus restricting the horizontal flow of ground water (see Figs. 1 and 2).

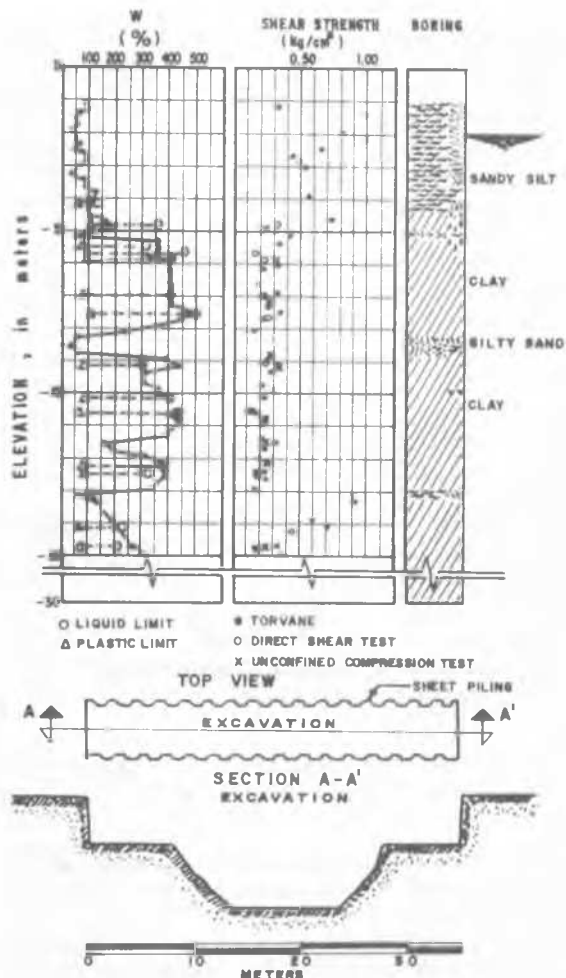

Fig. 1 Layout of the excavation for siphon No. 1, soil profile and soil properties.

The soil profile at both sites is similar, as shown in figures 1 and 2 and it consists of sandy silts and silty sand from 0 to 4.3 m in depth. Underlying these materials and down to a depth of 30 m there are deposits of a highly compressible soft clay of high plasticity with thin layers of sand and silt.



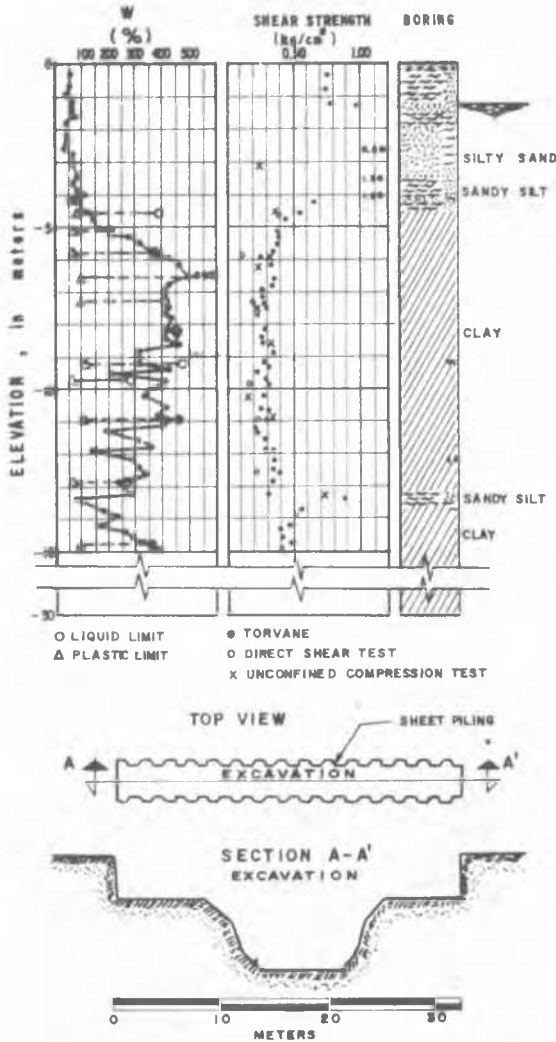

Fig 2. Layout of the excavation for siphon No. 2, soil profile and soil properties.

These figures also show the values of the natural water content ( $w$ ), the plasticity limits and the shear strength determined from Torvane measurements and from direct shear and unconfined compression tests. Two piezometric stations were installed at each siphon with readings taken prior to the excavation process and during its different stages. The variation of the piezometric level with time is shown in figures 3 and 4 for siphons No. 1 and 2 respectively, being referred to the excavation progress.

The curves of theoretical pore pressure were evaluated considering the discharge produced by the excavation as proposed by the theory of Boussinesq; such curves are shown in figures 5 and 6 for the different excavation stages for siphons Nos. 1 and 2 as well as the values corresponding

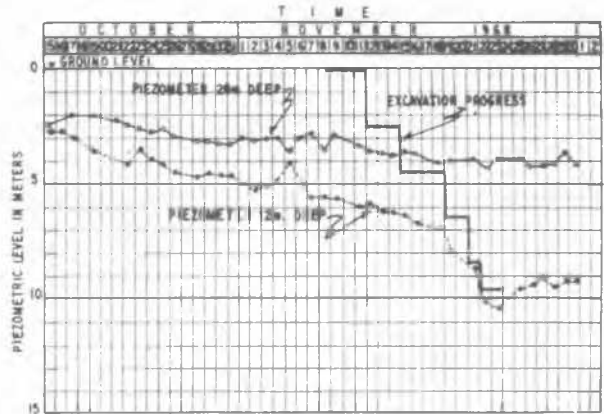

Fig 3. Variation of the piezometric level with time for different excavation stages at siphon No. 1.

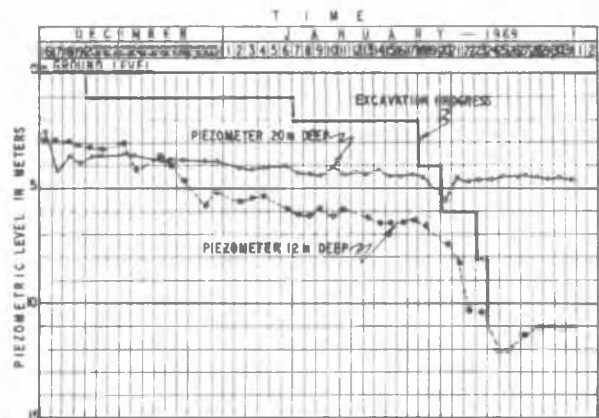

Fig 4. Variation of the piezometric level with time for different excavation stages at siphon No. 2.

to the pore pressures measured in the two piezometric stations installed at each siphon.

The slight variations shown in the figures 5 and 6 have been attributed to the increment of the pore pressure caused by the shearing strength assumed to be induced by the horizontal soil deformations. On the other hand the theory of Boussinesq is not fully applicable to the case being analysed since the sheet piling produces a discontinuity in the soil.

Measurements reported by Rodríguez and Flamand (1969)<sup>2</sup> for other siphon did not register the effect of the reduction in the pore pressures probably due to the fact that the horizontal soil deformations were very important, with a maximum value of 20 cm.

It will be interesting to corroborate this phenomenon in other excavations where the horizontal flow of ground water is restricted as well as to investigate such an effect in excavations without this restriction.

ACKNOWLEDGEMENTS.

The authors wish to thank Messrs. Luis Múndez P.

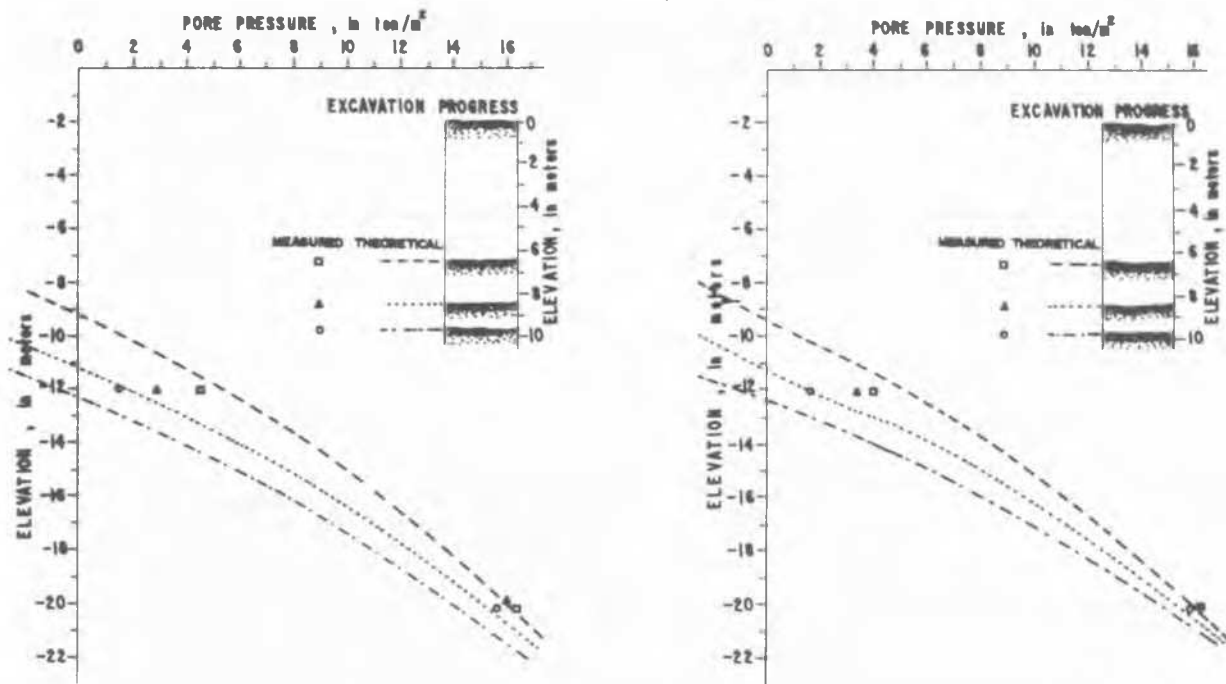

Fig 5. Theoretical and measured pore pressures at the two piezometric stations during different excavation stages in siphon No. 1.

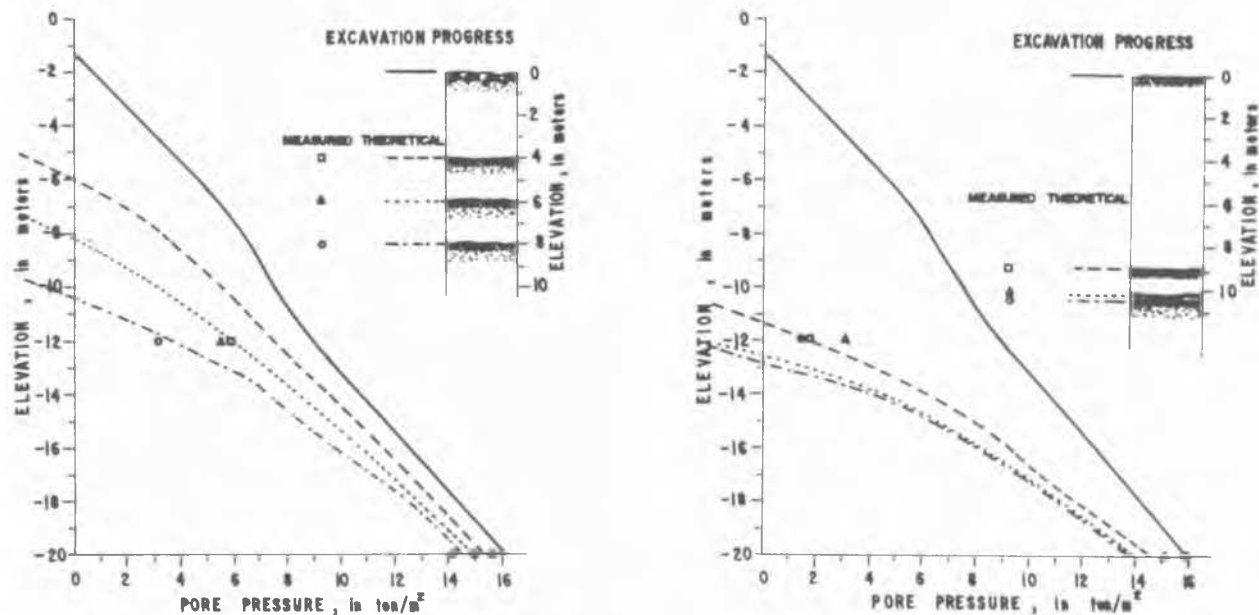

Fig 6. Theoretical and measured pore pressures at one piezometric station during successive excavation stages in siphon No. 2.

and Andrés Tentente for their invaluable assistance.

REFERENCES.

1. E. Juárez B. y A. Rico R; (1967). "Mecánica

de Suelos", Vol. II, Ed. Revista Ingeniería.

2. J.M. Rodríguez and C.L. Flamand (1969), "Strut Loads Recorded in a Deep Excavation in Clay", Proceedings Seventh Int. Conf. on Soil Mech. and Found. Eng., Vol. 2, pp. 459 - 467.